

///MARINEPOWER®

The Force Behind The Fun.™

5.0 L

&

5.7 L

ENGINE SERVICE MANUAL



17506 Marine Power Industrial Park
Ponchatoula, LA 70454

Parts Direct Line: (985) 386-3571 or (877) 388-9555

Parts Direct Fax: (985) 386-0076

Engine Mechanical 5.0L and 5-7L

Specifications

Fastener Tightening Specifications

Application	Specification	
	Metric	English
Accelerator Control Cable Bracket Bolt and Nut	12 N-m	106 lb in
Camshaft Retainer Bolt	12 N-m	106 lb in
Camshaft Sprocket Bolt	25 N-m	18 lb ft
Connecting Rod Nut		
First Pass	27 N-m	20 lb ft
Final Pass	55 degrees	
Crankshaft Balancer Bolt	95 N-m	70 lb ft
Crankshaft Bearing Cap Bolt and Stud (Preferred Method)		
First Pass (Two Bolt Type Bearing Cap)	20 N-m	15 lb ft
Final Pass (Two Bolt Type Bearing Cap)	73 degrees	
First Pass (Four Bolt Type Bearing Cap)	20 N-m	15 lb ft
Final Pass Outboard Bolt (Four Bolt Type Bearing Cap)	43 degrees	
Final Pass Inboard Bolt and Stud (Four Bolt Type Bearing Cap)	73 degrees	
Crankshaft Bearing Cap Bolt and Stud (Optional Strategy)		
Two Bolt Type Bearing Cap	105 N-m	77 lb ft
Inboard Bolt and Stud (Four Bolt Type Bearing Cap)	105 N-m	77 lb ft
Outboard Bolt (Four Bolt Type Bearing Cap)	90 N-m	66 lb ft
Crankshaft Oil Deflector Nut	40 N-m	30 lb ft
Crankshaft Position Sensor Bolt	9 N-m	80 lb in
Crankshaft Pulley Bolt	58 N-m	43 lb ft
Crankshaft Rear Oil Seal Housing Nut and Bolt	12 N-m	106 lb ft
Crankshaft Rear Oil Seal Housing Retainer Stud	6 N-m	53 lb in
Cylinder Head Bolt (Preferred Method)		
All Bolts First Pass in Sequence	30 N-m	22 lb ft
Long Bolts Final Pass in Sequence	75 degrees	
Medium Bolts Final Pass in Sequence	65 degrees	
Short Bolts Final Pass in Sequence	55 degrees	
Cylinder Head Core Hole Plug	20 N-m	15 lb ft
Distributor Cap Bolt	2.4 N-m	21 lb in
Distributor Clamp Bolt	25 N-m	18 lb ft
Engine Block Coolant Drain Hole Plug	20 N-m	15 lb ft
Engine Block Oil Gallery Plug	20 N-m	15 lb ft
Engine Coolant Temperature (ECT) Sensor	20 N-m	15 lb ft
Engine Flywheel Bolt	100 N-m	74 lb ft
Engine Front Cover Bolt	12 N-m	106 lb in
Engine Lift Bracket Bolt (Special Tool J 41427)	15 N-m	11 lb ft
Engine Lift Front Bracket Stud	35 N-m	26 lb ft
Engine Mount Bracket Bolt to Engine	54 N-m	40 lb ft
Engine Mount Nut (Through-Bolt)	68 N-m	50 lb ft
Engine Oil Pressure Gauge Sensor	30 N-m	22 lb ft
Engine Oil Pressure Gauge Sensor Fitting (Plus Required Angle)	15 N-m	11 lb ft
Engine Wiring Harness Bracket Nut	12 N-m	106 lb in

Fastener Tightening Specifications (cont'd)

Application	Specification	
	Metric	English
Exhaust Manifold Bolt		
First Pass	15 N-m	11 lb ft
Final Pass	30 N-m	22 lb ft
Fuel Pipe Bracket Bolt	6 N-m	53 lb in
Generator and Drive Belt Tensioner Bracket Bolt and Nut to Engine	41 N-m	30 lb ft
Ground Wire Bolt to Rear of Left Side Cylinder Head	16 N-m	12 lb ft
Ground Wire Nut to Rear of Right Side Cylinder Head	16 N-m	12 lb ft
Heater Hose Bracket Bolt to Generator and Drive Belt Tensioner Bracket	25 N-m	18 lb ft
Ignition Coil Stud	12 N-m	106 lb in
Knock Sensor	20 N-m	15 lb ft
Lower Intake Manifold Bolt		
First Pass in Sequence	3 N-m	27 lb in
Second Pass in Sequence	12 N-m	106 lb in
Final Pass in Sequence	15 N-m	11 lb ft
Oil Cooler Pipe Bracket to Oil Pan Bolt	12 N-m	106 lb in
Oil Filter Adapter Bolt	25 N-m	18 lb ft
Oil Filter Fitting	35 N-m	26 lb ft
Oil Level Indicator Tube Bolt	25 N-m	18 lb ft
Oil Pan Baffle Bolt	12 N-m	106 lb in
Oil Pan Bolt and Nut	25 N-m	18 lb ft
Oil Pan Bolt or Stud	12 N-m	106 lb in
Oil Pan Drain Plug	25 N-m	18 lb ft
Oil Pan Skid Plate Bolt	20 N-m	15 lb ft
Oil Pan Stud (Front)	6 N-m	53 lb in
Oil Pan Stud Nut	25 N-m	18 lb ft
Oil Pump Bolt to Rear Crankshaft Bearing Cap	90 N-m	66 lb ft
Oil Pump Cover Bolt	12 N-m	106 lb in
Power Steering Pump Rear Bracket Nut	50 N-m	37 lb ft
Secondary Air Injection (AIR) Check Valve Pipe Bracket Bolt to Exhaust Manifold	10 N-m	89 lb in
Secondary Air Injection (AIR) Check Valve Pipe Stud Nut	25 N-m	18 lb ft
Spark Plug		
Initial Installation (NEW Cylinder Head)	30 N-m	22 lb ft
All Subsequent Installations	15 N-m	11 lb ft
Spark Plug Wire Support Bolt	12 N-m	106 lb in
Starter Motor Wiring Harness Transmission Cooler Pipe Bracket to Oil Pan Bolt	9 N-m	80 lb in
Throttle Body Stud	9 N-m	80 lb in
Transmission to Oil Pan Bolt	47 N-m	35 lb ft
Dust Cover Bolt	12 N-m	106 lb in
Upper Intake Manifold Stud		
First Pass	5 N-m	44 lb in
Final Pass	9 N-m	80 lb in
Valve Lifter Pushrod Guide Bolt	16 N-m	12 lb ft
Valve Rocker Arm Bolt	30 N-m	22 lb ft
Valve Rocker Arm Cover Bolt	12 N-m	106 lb in
Water Outlet Stud	25 N-m	18 lb ft
Water Pump Bolt	45 N-m	33 lb ft
Water Pump Pulley Bolt	25 N-m	18 lb ft

Engine Mechanical Specifications (5.7L)

Application	Specification	
	Metric	English
General Data		
Engine Type	V8	
Displacement	4.3L	350 CID
RPO VIN Code)	L31 (R)	
Bore	101.63 mm	4.0012 in
Stroke	88.39 mm	3.480 in
Compression Ratio	9.4:1	
Firing Order	1-8-4-3-6-5-7-2	
Spark Plug Gap	1.52 mm	0.060 in
Oil Pressure (Minimum) at Normal Operating Temperature	42 kPa at 1,000 engine rpm 125 kPa at 2,000 engine rpm 166 kPa at 4,000 engine rpm	6.0 psig at 1,000 engine rpm 18.0 psig at 2,000 engine rpm 24.0 psig at 4,000 engine rpm
Camshaft		
End Play	0.05-0.30 mm	0.002-0.012 in
Journal Diameter	47.440-47.490 mm	1.8677-1.8696 in
Journal Diameter Out-of-Round	0.025 mm (Maximum)	0.0010 in (Maximum)
Lobe Lift (Exhaust)	7.20-7.30 mm	0.283-0.287 in
Lobe Lift (Intake)	6.97-7.07 mm	0.274-0.278 in
Runout	0.065 mm (Maximum)	0.0026 in (Maximum)
Connecting Rod		
Connecting Rod Bearing Clearance (Production)	0.033-0.078 mm	0.0013-0.0031 in
Connecting Rod Bearing Clearance (Service)	0.025-0.063 mm	0.0010-0.0025 in
Connecting Rod Side Clearance	0.15-0.68 mm	0.006-0.027 in
Connecting Rod Journal Diameter	53.304-53.334 mm	2.0986-2.0998 in
Connecting Rod Journal Taper (Production)	0.007 mm (Maximum)	0.0003 in (Maximum)
Connecting Rod Journal Taper (Service)	0.025 mm (Maximum)	0.0010 in (Maximum)
Connecting Rod Journal Out-of-Round (Production)	0.007 mm (Maximum)	0.0003 in (Maximum)
Connecting Rod Journal Out-of-Round (Service)	0.025 mm (Maximum)	0.0010 in (Maximum)
Crankshaft		
Crankshaft Bearing Clearance (Journal #1-Production)	0.018-0.053 mm	0.0007-0.0021 in
Crankshaft Bearing Clearance (Journal #2, #3 and #4-Production)	0.030-0.068 mm	0.0012-0.0027 in
Crankshaft Bearing Clearance (Journal #5-Production)	0.020-0.060 mm	0.0008-0.0024 in
Crankshaft Bearing Clearance (Journal #1-Service)	0.025-0.051 mm	0.0010-0.0020 in
Crankshaft Bearing Clearance (Journal #2, #3 and #4-Service)	0.025-0.064 mm	0.0010-0.025 in
Crankshaft Bearing Clearance (Journal #5-Service)	0.038-0.063 mm	0.0015-0.0025 in
Crankshaft End Play	0.050-0.20 mm	0.002-0.008 in
Crankshaft Journal Diameter (Journal #1)	62.189-62.212 mm	2.4484-2.4493 in
Crankshaft Journal Diameter (Journal #2 and #3)	62.181-62.207 mm	2.4481-2.4491 in
Crankshaft Journal Diameter (Journal #5)	62.185-62.207 mm	2.4482-2.4491 in
Crankshaft Journal Out-of-Round (Production)	0.005 mm (Maximum)	0.0002 in (Maximum)
Crankshaft Journal Out-of-Round (Service)	0.025 mm (Maximum)	0.0010 in (Maximum)
Crankshaft Journal Taper (Production)	0.005 mm (Maximum)	0.0002 in (Maximum)
Crankshaft Journal Taper (Service)	0.025 mm (Maximum)	0.0010 in (Maximum)
Crankshaft Runout at Rear Flange	0.038 mm (Maximum)	0.0015 in (Maximum)

Engine Mechanical Specifications (5.7L) (cont'd)

Application	Specification	
	Metric	English
Cylinder Bore		
Diameter	101.618-101.643 mm	4.0007- 4.0017 in
Out-of-Round (Production)	0.025 mm (Maximum)	0.0010 in (Maximum)
Out-of-Round (Service)	0.05 mm (Maximum)	0.002 In (Maximum)
Taper (Production-Relief Side)	0.025 mm (Maximum)	0.0010 in (Maximum)
Taper (Production-Thrust Side)	0.012 mm (Maximum)	0.0005 in (Maximum)
Taper (Service Limit)	0.025 mm (Maximum)	0.0010 in (Maximum)
Cylinder Head		
Surface Flatness (Engine Block Deck)	0.10 mm (Maximum)	0.004 in (Maximum)
Surface Flatness (Exhaust Manifold Deck)	0.05 mm (Maximum)	0.002 in (Maximum)
Surface Flatness (intake Manifold Deck)	0.10 mm (Maximum)	0.004 In (Maximum)
Exhaust Manifold		
Surface Flatness (Range to Flange)	0.25 mm (Maximum)	.010 in (Maximum)
Surface Flatness (individual Flange)	0.05 mm (Maximum)	0.002 in (Maximum)
Piston		
Piston Bore Clearance (Production)	0.018-0.053	0.0007-0.002 in
Piston Bore Clearance (Service)	0.018-0.053 mm	0.0007-0.002 in
Piston Pin		
Clearance in Piston (Production)	0.013-0.023 mm	0.0005-0.0009 in
Clearance in Piston (Service)	0.013-0.025 mm	0.0005-0.0010 in
Diameter	23.545-23.548 mm	0.9270-0.9271 in
Fit in Connecting Rod	0.021-0.040 mm (interference)	0.0008-0.0016 in (interference)
Piston Rings (End Gap Measured In Cylinder Bore)		
Piston Compression Ring Gap (Production-Top Groove)	0.25-0.40 mm	0.098-0.015 in
Piston Compression Ring Gap (Production- 2nd Groove)	0.46-0.66 mm	0.018-0.025 in
Piston Compression Ring Gap (Service -Top Groove)	0.25-0.50 mm	0.009-0.019 in
Piston Compression Ring Gap (Service - 2nd Groove)	0.46-0.80 mm	0.018-0.031 in
Piston Compression Ring Groove Clearance (Production-Top Groove)	0.030-0.070 mm	0.0012-0.0027 in
Piston Compression Ring Groove Clearance (Production- 2nd Groove)	0.040-0.080 mm	0.0015-0.003 in
Piston Compression Ring Groove Clearance (Service-Top Groove)	0.030-0.090 mm	0.0012-0.0035 in
Piston Compression Ring Groove Clearance (Service-2nd Groove)	0.040-0.100 mm	0.0015-0.0040 in
Piston Oil Ring Gap (Production)	0.25-0.76 mm	0.009-0.029 in
Piston Oil Ring Gap (Service)	0.25-0.90 mm	0.009-0.035 in
Piston Oil Ring Groove Clearance (Production)	0.046-0.096 mm	0.0018-0.0037 in
Piston Oil Ring Groove Clearance (Service)	0.046-0.100 mm	0.0018-0.0039 in
Valve System		
Valve Face Angle	45 Degrees	
Valve Head Edge Margin	0.79 mm (Minimum)	0.031 in (Minimum)
Valve Lash	Rotate the Valve Rocker And Nut Clockwise 360 degrees (1 Turn) from Zero Lash	
Valve Lifter	Hydraulic Roller	
Valve Rocker Arm Ratio	1.5:1	
Valve Seat Angle	46 Degrees	

Engine Mechanical Specifications (5.7L) (cont'd)

Application	Specification	
	Metric	English
Valve Seat Runout	0.05 mm (Maximum)	0.002 in (Maximum)
Valve Seat Width (Exhaust-Heavy Duty)	1.50-2.56 mm	0.059-0.101 in
Valve Seat Width (Exhaust-Light Duty)	1.65-2.49 mm	0.065-0.098 in
Valve Seat Width (intake)	1.02-1.65 mm	0.040-0.065 in
Valve Spring Free Length	51.3 mm	2.02 in
Valve Spring Installed Height (Exhaust)	42.92-43.43 mm	1.67-1.70 in
Valve Spring Installed Height (Intake)	42.92-43.43 mm	1.67-1.70 in
Valve Spring Pressure (Closed)	338-374 N at 43.2 mm	76-84 lb at 1.70 in
Valve Spring Pressure (Open)	832-903 N at 32.3 mm	187-203 lb at 1.27 in
Valve Stem Clearance (Exhaust-Producton)	0.025-0.069 mm	0.0010-0.0027 in
Valve Stem Clearance (Intake-Producton)	0.025-0.069 mm	0.0010-0.0027 in
Valve Stem Clearance (Exhaust-Service)	0.025-0.094 mm	0.0010-0.0037 in
Valve Stem Clearance (intake-Service)	0.025-0.094 mm	0.0010-0.0037 in
Valve Stem Diameter	8.661-8.679 mm	0.3410-0.3416 in
Valve Stem Oil Seal Installed Height (Measured from the Top of the Large Valve Guide Bevel to the Bottom of the Valve Stem Oil Seal)	1-2 mm	0.03937-0.07874 in

Engine Mechanical Specifications (5.0 L)

Application	Specification	
	Metric	English
General Data		
Engine Type	V8	
Displacement	5.0 L 1	305 CID
RPO - VIN Code	L30 (M)	
Bore	94.89 mm	3.737 in
Stroke	88.39 mm	3.480 in
Compression Ratio	9.4:1	
Firing Order	1-8-4-3-6-5-7-2	
Spark Plug Gap	1.52 mm	0.060 in
Oil Pressure - Minimum at Normal Operating Temperature	42 kPa at 1,000 RPM 125 kPa at 2,000 RPM 1 166 kPa at 4,000 RPM	6 psig at 1,000 RPM 18 psig at 2,000 RPM 24 psig at 4,000 RPM
Camshaft		
End Play	0.054-0.30 mm	0.002-0.012 in
Journal Diameter	47.440-47.490 mm	1.8677-1.8697 in
Journal Diameter Out-of-Round	0.025 mm	0.0010 in
Lobe Lift - Exhaust	7.20-7.30 mm	0.283-0.287 in
Lobe Lift - Intake	6.97-7.07 mm	0.274-0.278 in
Runout	0.065 mm - Maximum	0.0026 in - Maximum
Connecting Rod		
Connecting Rod Bearing Clearance - Production	0.033-0.078 mm	0.0013-0.0031 in
Connecting Rod Bearing Clearance - Service	0.025-0.063 mm	0.0010-0.0025 in
Connecting Rod Journal Diameter	56.505-56.533 mm	2.2246-2.2257 in
Connecting Rod Journal Out-of-Round - Production	0.007 mm - Maximum	0.0003 in - Maximum
Connecting Rod Journal Out-of-Round - Service	0.025 mm - Maximum	0.0010 in - Maximum
Connecting Rod Journal Taper - Production	0.007 mm - Maximum	0.0003 in - Maximum
Connecting Rod Journal Taper - Service	0.025 mm - Maximum	0.0010 in - Maximum
Connecting Rod Side Clearance	0.15-0.61 mm-	0.006-0.024 in
Crankshaft		
Crankshaft Bearing Clearance - Journal #1 - Production	0.018-0.053 mm	0.0007-0.0021 in
Crankshaft Bearing Clearance - Journal #2, #3, and #4 - Production	0.030-0.068 mm	0.0012-0.0027 in
Crankshaft Bearing Clearance - Journal #5 - Production	0.020-0.060 mm	0.0008-0.0024 in
Crankshaft Bearing Clearance - Journal #1 - Service	0.025-0.051 mm	0.0010-0.0020 in
Crankshaft Bearing Clearance - Journal #2, #3, and #4 - Service	0.025-0.064 mm	0.0010-0.0025 in
Crankshaft Bearing Clearance - Journal #5 - Service	0.038-0.063 mm	0.0015-0.0025 in
Crankshaft End Play	0.05-0.20 mm	0.002-0.008 in
Crankshaft Journal Diameter - Journal #1	62.189-62.212 mm	2.4484-2.4493 in
Crankshaft Journal Diameter - Journal #2, #3, and #4	62.181-62.207 mm	2.4481-2.4491 in
Crankshaft Journal Diameter - Journal #5	62.185-62.207 mm	2.4482-2.4491 in
Crankshaft Journal Out-of-Round - Production	0.005 mm - Maximum	0.0002 in - Maximum
Crankshaft Journal Out-of-Round - Service	0.025 mm - Maximum	0.0010 in - Maximum
Crankshaft Journal Taper - Production	0.005 mm - Maximum	0.0002 in - Maximum
Crankshaft Journal Taper - Service	0.025 mm - Maximum	0.0010 in - Maximum
Crankshaft Runout at Rear Flange	0.038 mm	0.0015 in
Cylinder Bore		
Diameter	94.894-94.947 mm	3.7360-3.7381 in
Out-of-Round - Production	0.025 mm	0.0010 in

Engine Mechanical Specifications (5.0 L)

Application	Specification	
	Metric	English
Out-of-Round -Service	0.05 mm	0.002 in
Taper - Production - Relief Side	0.025 mm	0.0010 in
Taper - Production - Thrust Side	0.012 mm	0.0005 in
Taper - Service Limit	0.025 mm	0.0010 in
Cylinder Head		
Surface Flatness - Engine Block Deck	0.10 mm	0.004 in
Surface Flatness - Exhaust Manifold Deck	0.05 mm	0.002 in
Surface Flatness - Intake Manifold Deck	0.10 mm	0.004 in
Exhaust Manifold		
Surface Flatness - Flange to Flange	0.25 mm	0.010 in
Surface Flatness - Individual Flange	0.05 mm	0.0021n
Piston		
Piston Bore Clearance - Production	0.018-0.061 mm	0.0007-0.0024 in
Piston Bore Clearance - Service	0.018-0.068 mm	0.0007-0.0026 in
Piston Pin		
Clearance in Piston - Production	0.010-0.020 mm	0.0004-0.0008 in
Clearance in Piston - Service	0.013-0.025 mm	0.0005-0.0010 in
Diameter	23.545-23.548 mm	0.9270-0.9271 in
Interference Fit in Connecting Rod	0.012-0.050 mm	0.0004-0.0019 in
Piston Rings - End Gap Measured in Cylinder Bore		
Piston Compression Ring Gap - Production - Top Groove	0.25-0.51 mm	0.010-0.020 in
Piston Compression Ring Gap - Production - 2nd Groove	0.46-0.66 mm	0.018-0.026 in
Piston Compression Ring Gap - Service - Top Groove	0.25-0.65 mm	0.010-0.025 in
Piston Compression Ring Gap - Service - 2nd Groove	0.46-0.90 mm	0.018-0.035 in
Piston Compression Ring Groove Clearance - Production - Top Groove	0.030-0.070 mm	0.0012-0.0027 in
Piston Compression Ring Groove Clearance - Production - 2nd Groove	0.030-0.074 mm	0.0012-0.003 in
Piston Compression Ring Groove Clearance - Service Limit - Top Groove	0.030-0.090 mm	0.0012-0.0035 in
Piston Compression Ring Groove Clearance - Service Limit - 2nd Groove	0.030-0.090 mm	0.0012-0.0040 in
Piston Oil Ring Gap - Production	0.25-0.76 mm	0.010-0.030 in
Piston Oil Ring Gap - Service	0.25-0.89 mm	0.010-0.035 in
Piston Oil Ring Groove Clearance - Production	0.051-0.203 mm	0.002-0.008 in
Piston Oil Ring Groove Clearance - Service	0.051-0.22 mm	0.002-0.009 in
Valve System		
Valve Face Angle	45 degrees	
Valve Head Edge Margin	0.79 mm - Minimum	0.031 in - Minimum
Valve Lash	Rotate the Valve Rocker Arm Nut Clockwise 360 degrees from Zero Lash	
Valve Lifter	Hydraulic Roller	
Valve Rocker Arm Ratio	1.5:1	
Valve Seat Angle	46 degrees	
Valve Seat Runout	0.05 mm - Maximum	0.002 in - Maximum
Valve Seat Width - Exhaust	1.65-2.49 mm	0.065-0.098 in
Valve Seat Width - Intake	1.14-1.78 mm	0.045-0.070 in
Valve Spring Free Length	51.3 mm	2.02 in
Valve Spring Installed Height - Exhaust	42.92-43.43 mm	1.67-1.70 in
Valve Spring Installed Height - Intake	42.92-43.43 mm	1.67-1.70 in
Valve Spring Pressure - Closed	338-374 N at 43.2 mm	76-84 lb at 1.70 in

Engine Mechanical Specifications (5.0 L)

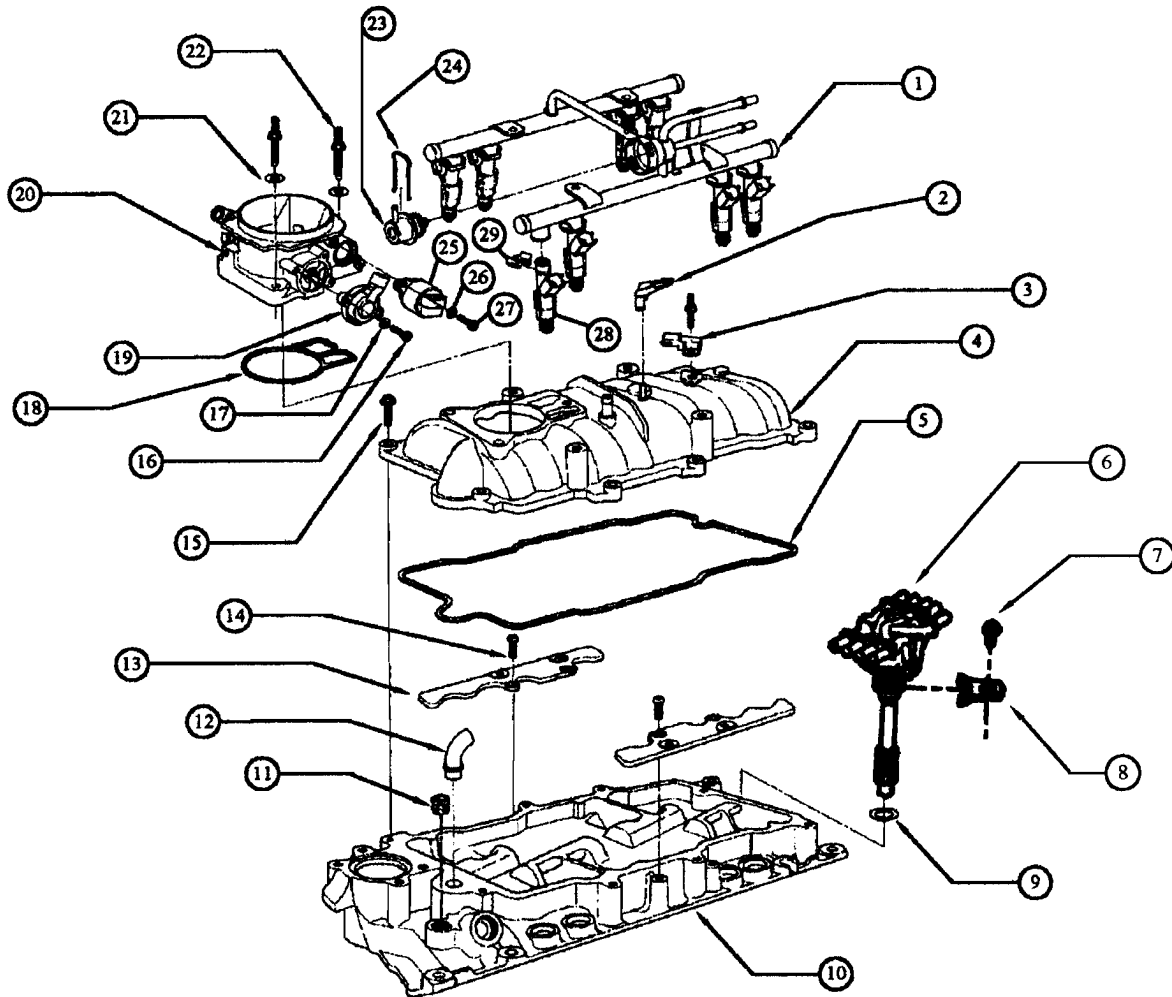
Application	Specification	
	Metric	English
Valve Spring Pressure - Open	832-903 N at 32.3 mm	187-203 lb at 1.27 in
Valve Stem Clearance - Exhaust - Production	0.025-0.069 mm	0.0010-0.0027 in
Valve Stem Clearance - Intake - Production	0.025-0.069 mm	0.0010-0.0027 in
Valve Stem Clearance - Exhaust - Service	0.025-0.094 mm	0.0010-0.0037 in
Valve Stem Clearance - Intake - Service	0.025-0.094 mm	0.0010-0.0037 in
Valve Stem Diameter	8.661-8.679 mm	0.3410-0.3416 in
Valve Stem Oil Seal Installed Height - Measured from the Top of the Large Diameter Valve Guide Bevel to the Bottom of the Valve Stem Oil Seal	1-2 mm	0.03937-0.07874 in

Component Locator

Disassembled Views

SSE-ID - 348808

Intake Manifolds and Components 880-ID - 67234

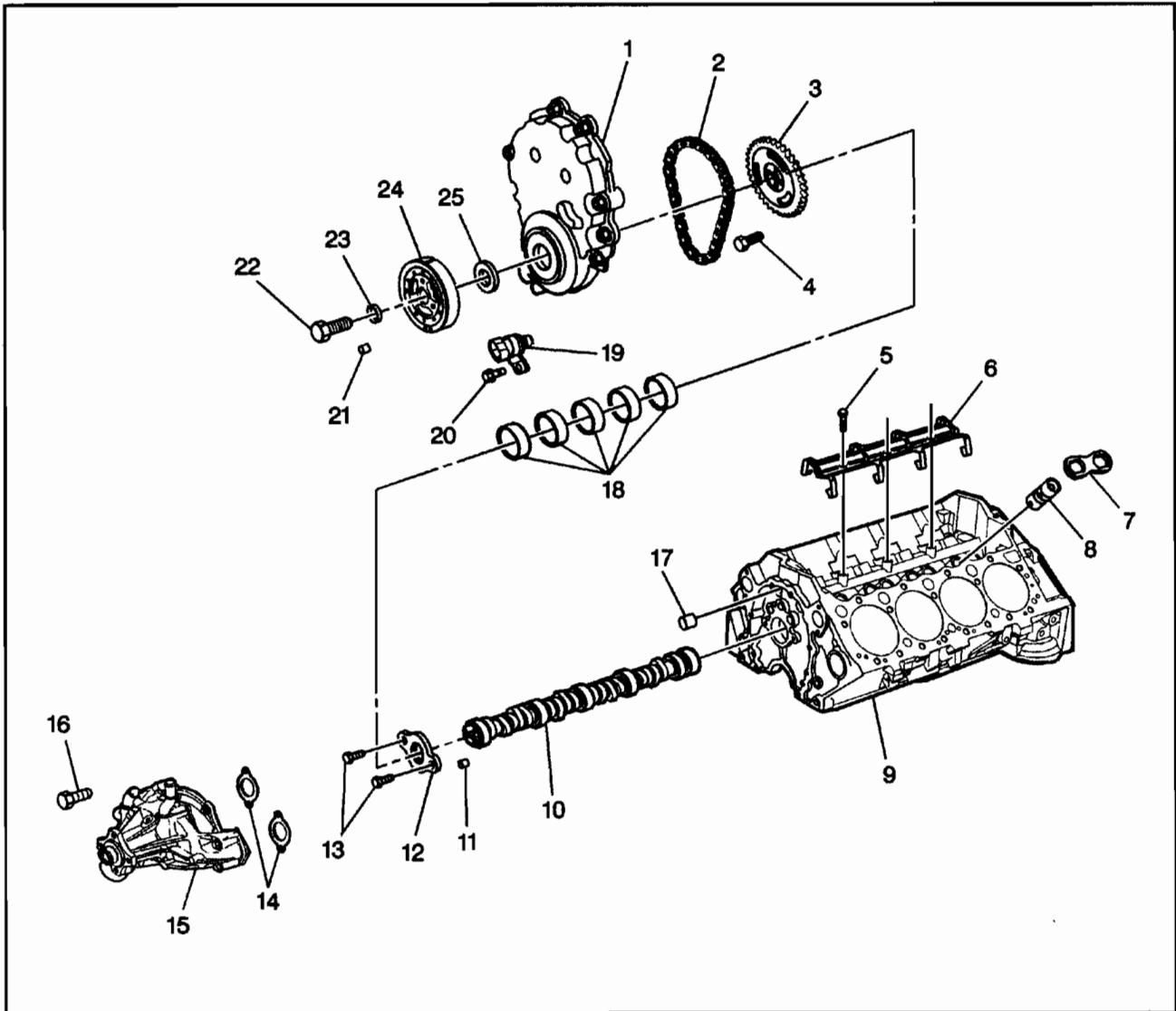


Legend

- | | |
|--|--------------------------------------|
| 1. Fuel Rail | 11. 3/8 in. Plug |
| 2. Pressure Regulator Vacuum Tube Assembly | 12. Water Outlet |
| 3. Bosch Mapp and Mat Sensor | 13. Coil Pack Mounting Bracket |
| 4. Upper Plenum | 14. Coil Pack Mounting Bracket Bolt |
| 5. Upper Plenum Bracket | 15. Upper Plenum Mounting Bolt |
| 6. HVS (High Voltage Switch) | 16. TPS mounting bolt |
| 7. HVS Bolt | 17. TPS washer |
| 8. Clamp | 18. Throttle Body Gasket |
| 9. Distributor Gasket (seal) | 19. TPS (Throttle Position Sensor) |
| 10. Lower Plenum | 20. Throttle Body |

21. Washer
 22. GM Double Post Mount Screw
 23. Fuel Pressure Regulator
 24. Fuel Pressure Regulator Retainer Clip
 25. IAC (Idle Air Control)
 26. IAC washer
 27. IAC mounting bolt
 28. Fuel Injector
 29. Fuel Injector Retainer Clip
-

Front of Engine SIO-ID = 197523

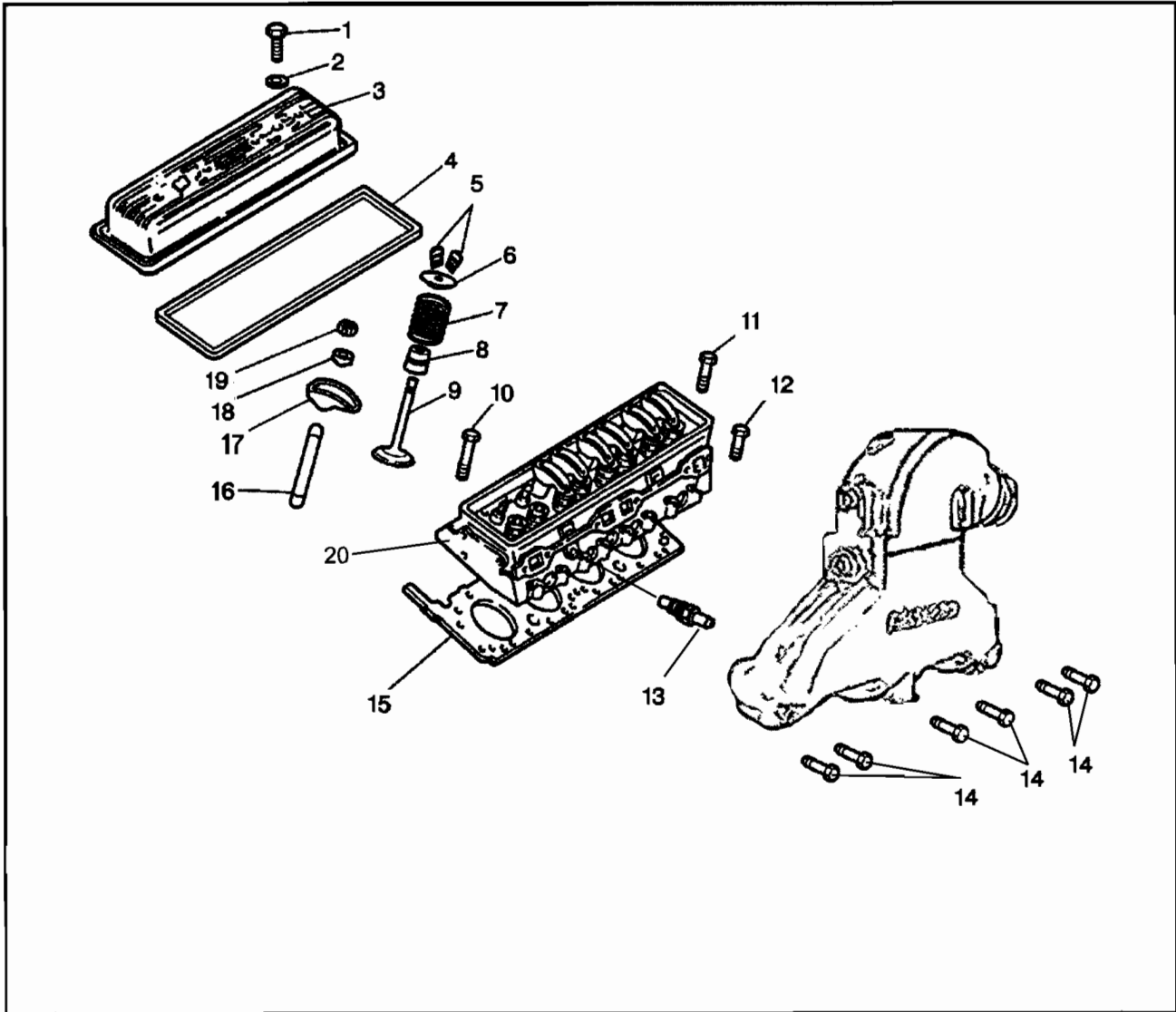


182828

Legend

- | | |
|--------------------------------------|---|
| (1) Engine Front Cover | (15) Water Pump |
| (2) Camshaft Timing Chain | (16) Water Pump Bolt |
| (3) Camshaft Sprocket | (17) Engine Block Oil Gallery Plug |
| (4) Camshaft Sprocket Bolt | (18) Camshaft Bearings |
| (5) Valve Lifter Guide Retainer Bolt | (19) Crankshaft Position Sensor |
| (6) Valve Lifter Guide Retainer | (20) Crankshaft Position Sensor Bolt |
| (7) Valve Lifter Guide | (21) Front Groove Pin (Crankshaft Balancer) |
| (8) Valve Lifter | (22) Crankshaft Balancer Bolt |
| (9) Engine Block | (23) Crankshaft Balancer Bolt Washer |
| (10) Engine Camshaft | (24) Crankshaft Balancer |
| (11) Camshaft Sprocket Locator Pin | (25) Crankshaft Front Oil Seal |
| (12) Camshaft Retainer | |
| (13) Camshaft Retainer Bolt | |
| (14) Water Pump Gasket | |

Cylinder Head and Exhaust Manifold Area SIO-ID = 197712



182825

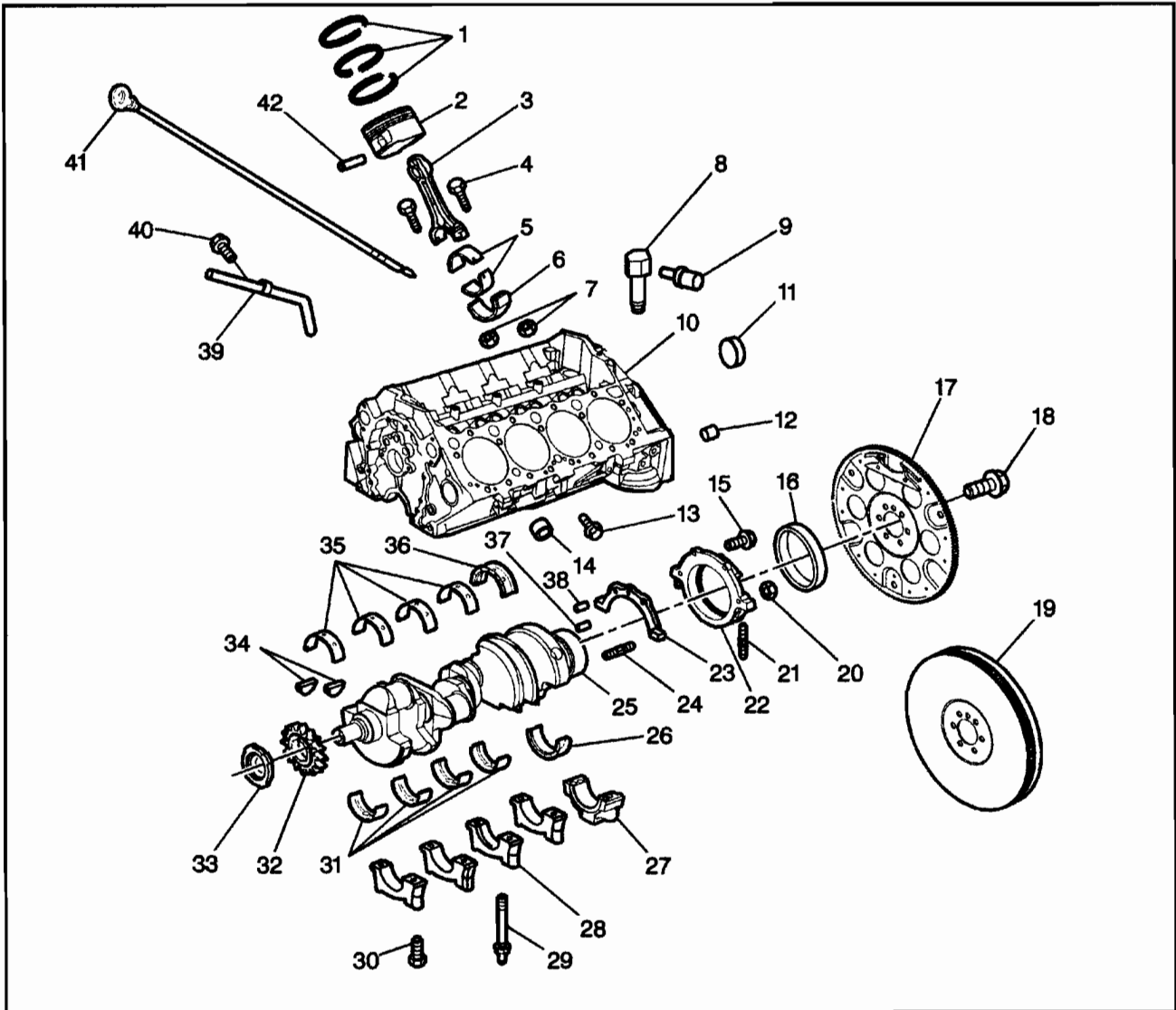
Legend

- | | |
|--|-----------------------------|
| (1) Valve Rocker Arm Cover Bolt | (14) Exhaust Manifold Bolts |
| (2) Valve Rocker Arm Cover Bolt Washer | (15) Cylinder Head Gasket |
| (3) Valve Rocker Arm Cover | (16) Valve Pushrod |
| (4) Valve Rocker Arm Cover Gasket | (17) Valve Rocker Arm |
| (5) Valve Stem Keys | (18) Valve Rocker Arm Ball |
| (6) Valve Spring Cap | (19) Valve Rocker Arm Nut |
| (7) Valve Spring | (20) Exhaust Manifold |
| (8) Valve Stem Oil Seal | |
| (9) Valve | |
| (10) Cylinder Head Bolt (Long) | |
| (11) Cylinder Head Bolt (Medium) | |
| (12) Cylinder Head Bolt (Short) | |
| (13) Engine Coolant Temperature (ECT) Gauge Sensor | |

Note:

There are no exhaust manifold gaskets. High temp. silicone is used in its place.

Cylinder Block and Components SIO-ID = 348439



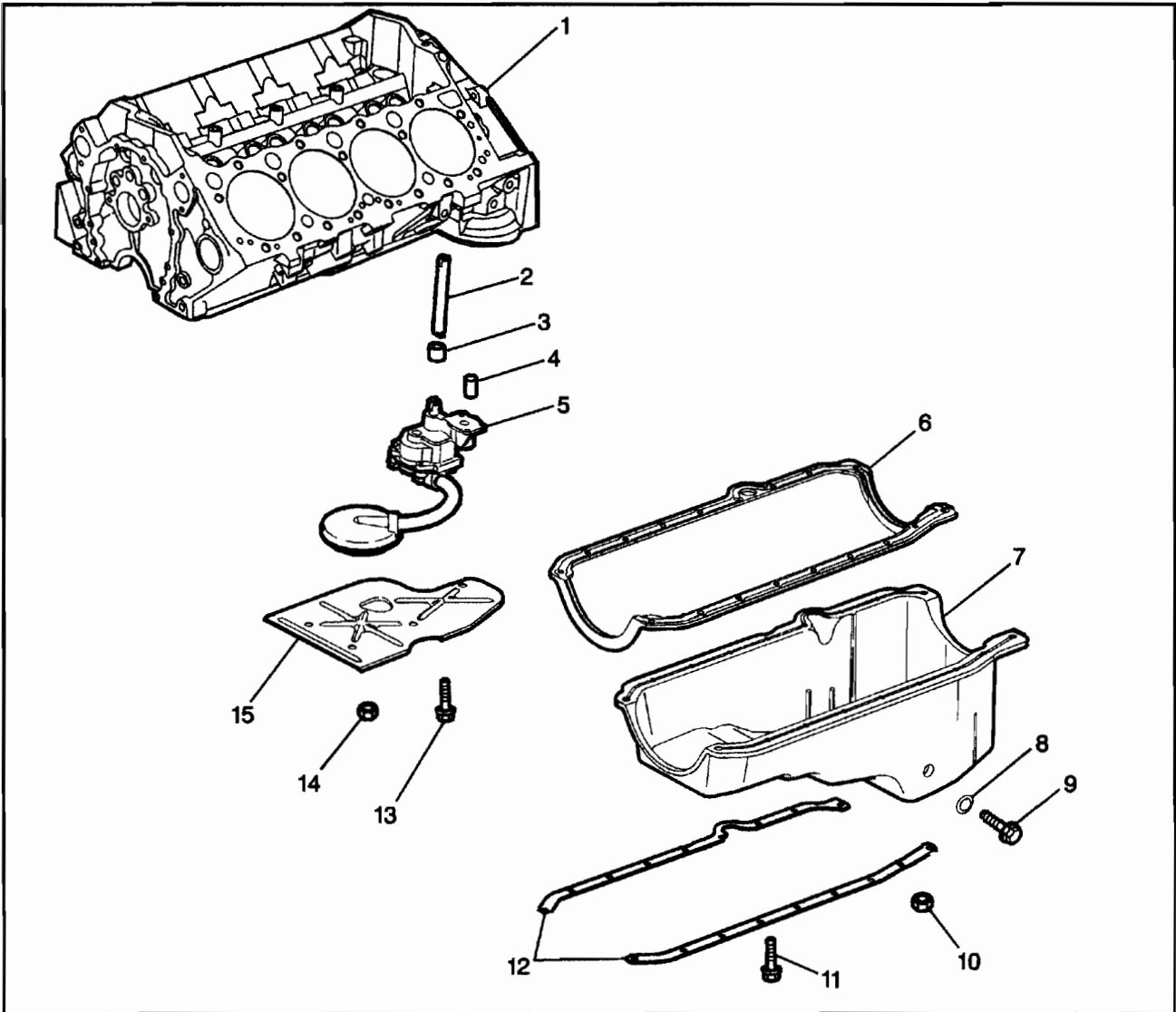
317429

Legend

- | | |
|--|---|
| (1) Piston Ring Kit | (16) Crankshaft Rear Oil Seal |
| (2) Piston | (17) Engine Flywheel (Automatic Transmission) |
| (3) Connecting Rod | (18) Flywheel Bolt |
| (4) Connecting Rod Bolt | (19) Engine Flywheel (Manual Transmission) |
| (5) Connecting Rod Bearings | (20) Crankshaft Rear Oil Seal Housing Nut |
| (6) Connecting Rod Cap | (21) Crankshaft Rear Oil Seal Housing Stud |
| (7) Hex Nut (Connecting Rod) | (22) Crankshaft Rear Oil Seal Housing |
| (8) Engine Oil Pressure Gauge Sensor Fitting | (23) Crankshaft Rear Oil Seal Housing Gasket |
| (9) Engine Oil Pressure Gauge Sensor | (24) Crankshaft Rear Oil Seal Housing Stud |
| (10) Engine Block | (25) Crankshaft |
| (11) Expansion Cup Plug (Camshaft Rear Bearing Hole) | (26) Crankshaft Bearing (Rear Thrust Bearing) |
| (12) Dowel Straight Pin (Transmission Locator) | (27) Crankshaft Bearing Cap (Rear) |
| (13) Engine Block Coolant Drain Hole Plug | (28) Crankshaft Bearing Cap |
| (14) Engine Block Core Hole Plug | (29) Crankshaft Bearing Cap Stud |
| (15) Crankshaft Rear Oil Seal Housing Bolt | (30) Crankshaft Bearing Cap Bolt |
| | (31) Crankshaft Bearings |

-
- | | |
|---|---|
| (32) Crankshaft Sprocket | (38) Spring Type S Pin (Crankshaft Rear Oil Seal Housing Locator) |
| (33) Crankshaft Position Sensor Reluctor Ring | (39) Oil Level Indicator Tube |
| (34) Woodruff Keys (Crankshaft Balancer) | (40) Oil Level Indicator Tube Bolt |
| (35) Crankshaft Bearing | (41) Oil Level Indicator |
| (36) Crankshaft Bearing (Rear Thrust Bearing) | (42) Piston Pin |
| (37) Spring Type S Pin (Flywheel Locator) | |
-

Bottom of Engine SIO-ID = 197524



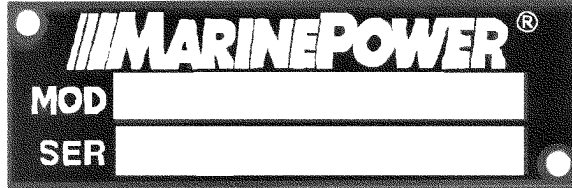
182829

Legend

- | | |
|--------------------------------------|------------------------------------|
| (1) Engine Block | (9) Oil Pan Drain Plug |
| (2) Oil Pump Driveshaft | (10) Oil Pan Nut |
| (3) Oil Pump Driveshaft Retainer | (11) Oil Pan Bolt |
| (4) Pin (Oil Pump Locator) | (12) Oil Pan Reinforcement |
| (5) Oil Pump | (13) Crankshaft Oil Deflector Bolt |
| (6) Oil Pan Gasket | (14) Crankshaft Oil Deflector Nut |
| (7) Oil Pan | (15) Crankshaft Oil Deflector |
| (8) Oil Pan Drain Plug Seal (O-ring) | |

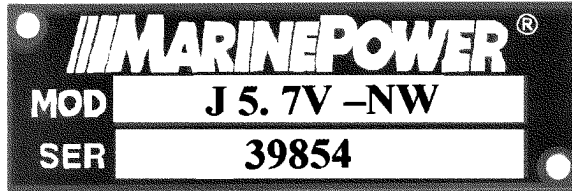
Engine Identification

The Model and Serial numbers are located on stamped plates
Located on the starboard head just under the valve cover.



The Model number identifies the type of engine, the engine
Displacement, and the engine package.

Example:



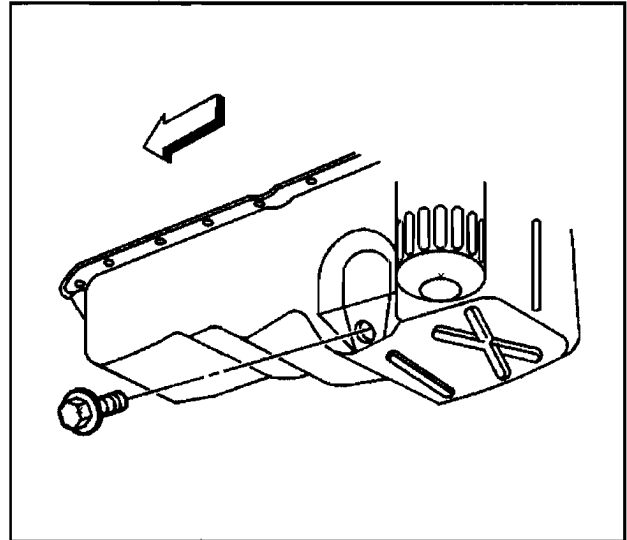
Type	Jet
Displacement	5.7L
Engine Package	Northwest Package

Repair Instructions

Draining Fluids and Oil Filter Removal

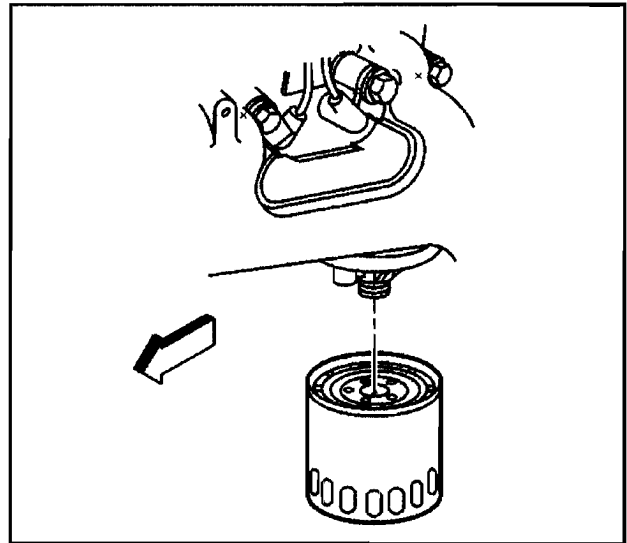
SIE-ID = 194572

1. Remove the oil pan drain plug and allow the engine oil to drain into a suitable container.



182850

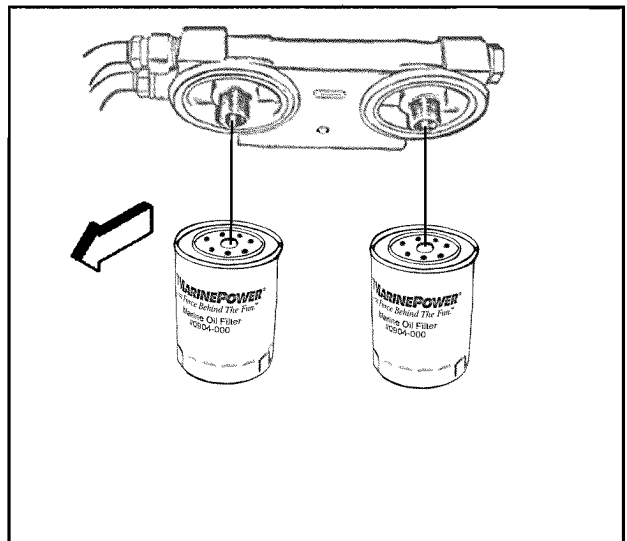
2. Remove the oil filter and discard.

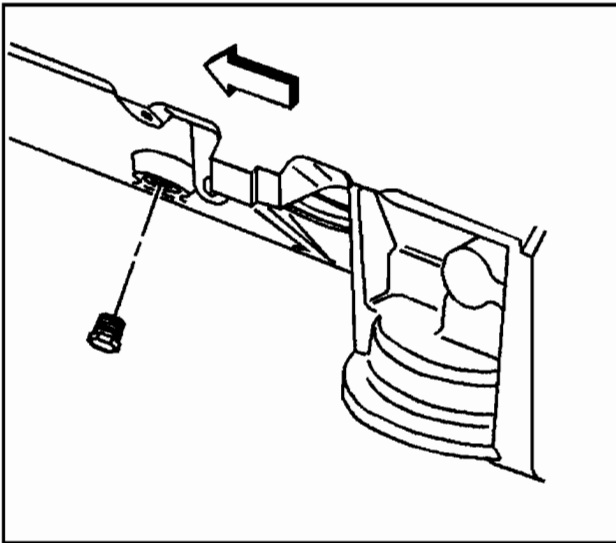


316766

If your engine is equipped with a Remote oil filtration system, then

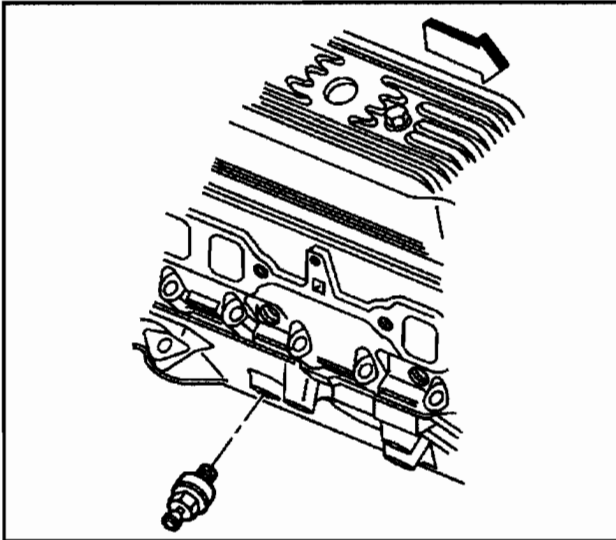
1. Locate your remote filter or filters, generally located on the top front or top rear of the engine.
2. Remove the oil filter or filters and discard.





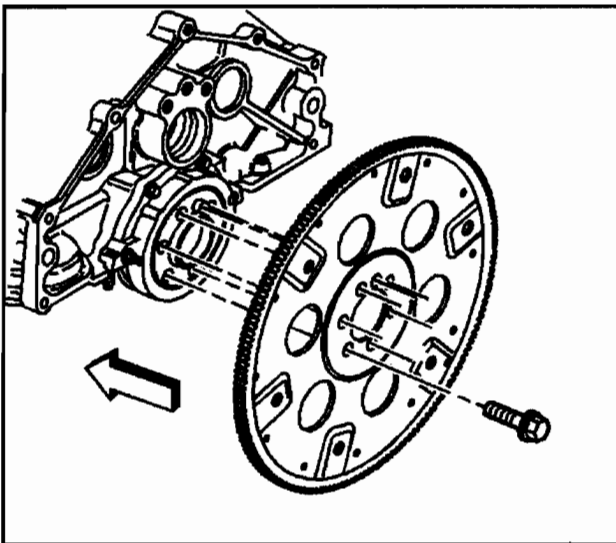
316798

3. Remove the engine block coolant drain hole plug and allow the coolant to drain into a suitable container.



182837

4. Remove the knock sensor and allow the coolant to drain into a suitable container.



522146

Engine Flywheel Removal

SIE-ID = 527623

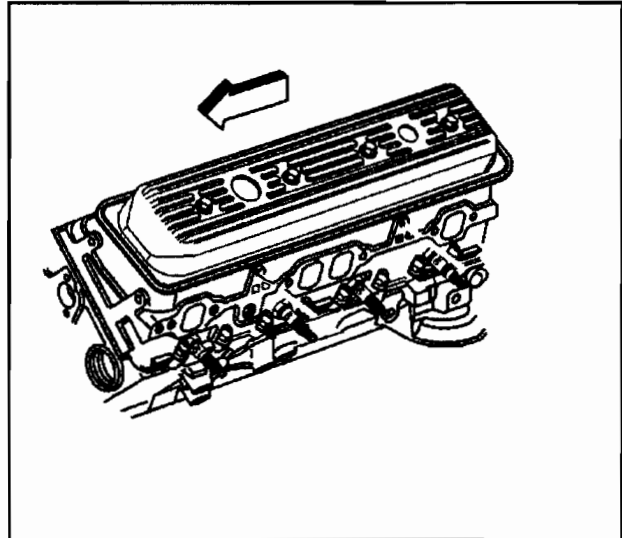
1. Remove the engine flywheel bolts.
2. Remove the engine flywheel.

Exhaust Manifold Removal - Left

SIE-ID = 650059

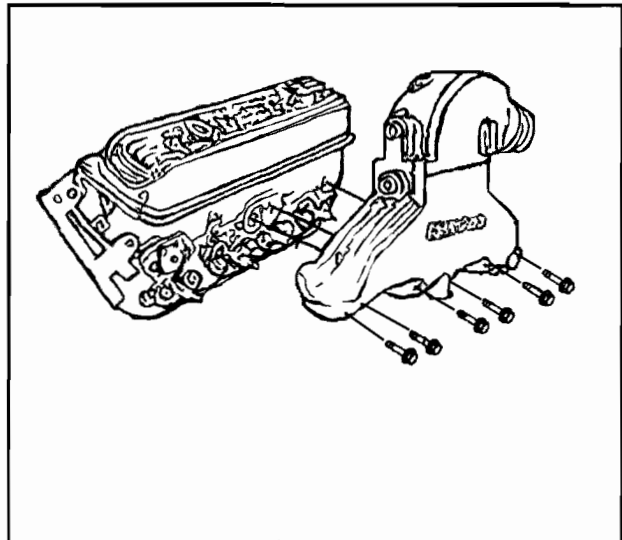
Notice: SIO-ID = 2878 Twist the spark plug boot one-half turn in order to release the boot. Pull on the spark plug boot only. Do not pull on the spark plug wire or the wire could be damaged.

1. Remove the spark plug wires from the spark plugs.
 - 1.1. Rotate the spark plug wire boot one half turn.
 - 1.2. Pull outward on the spark plug wire boot to release from the spark plug.
2. Remove the bolts and the spark plug wire supports.

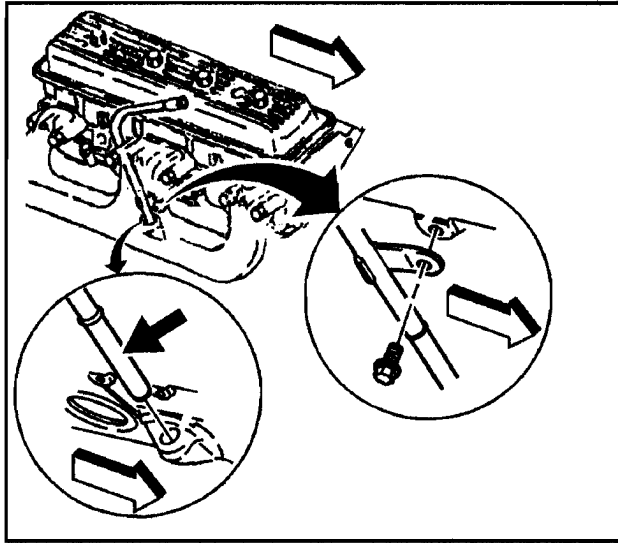


317185

3. Remove the exhaust manifold bolts.
4. Remove the spark plug wire shields.
5. Remove the exhaust manifold.



64925

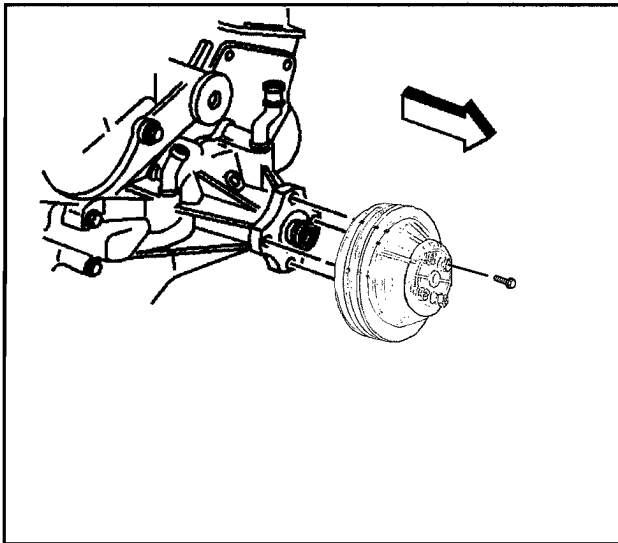


500691

Oil Level Indicator and Tube Removal

SIE-ID = 518523

1. Remove the oil level indicator tube bolt.
2. Remove the oil level indicator tube from the engine block.

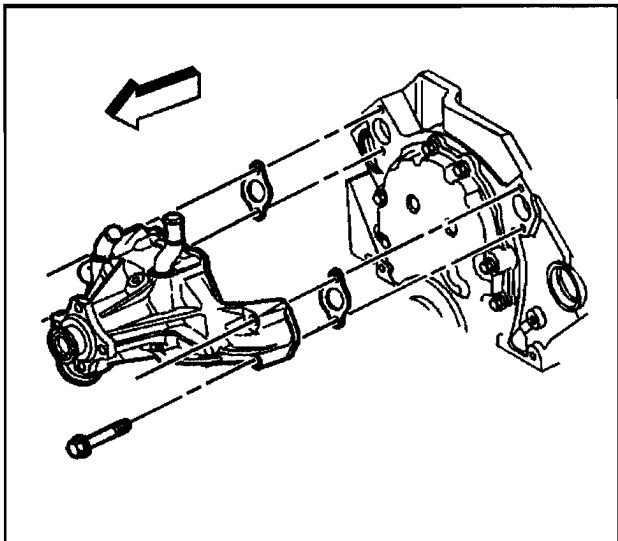


317191

Water Pump Removal

SIE-ID = 69041

1. Remove the bolts and water pump pulley



69011

2. Remove the water pump bolts.
3. Remove the water pump.
4. Remove the water pump gaskets.
5. Discard the water pump gaskets.

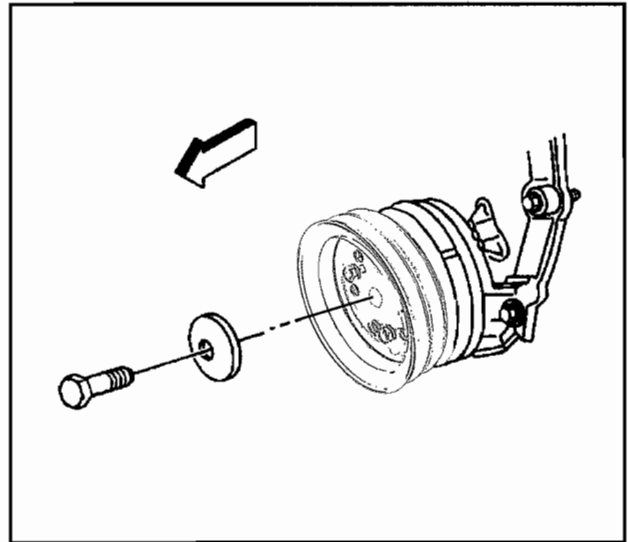
Crankshaft Balancer Removal

SIE-ID = 66662

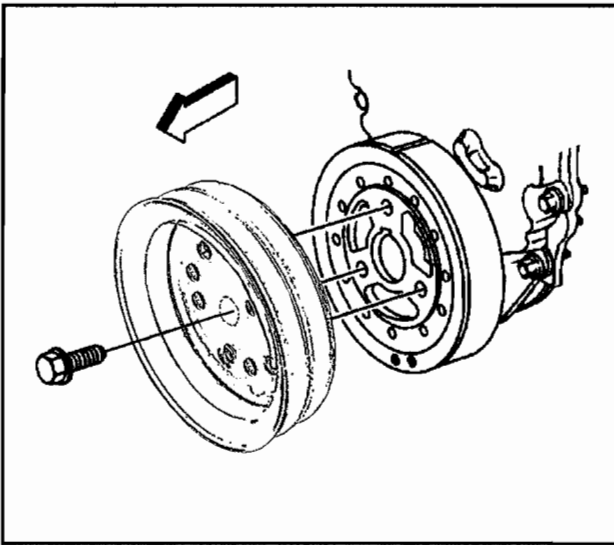
Tools Required

J 23523-F Balancer Remover and Installer

1. Remove the crankshaft balancer bolt and washer.

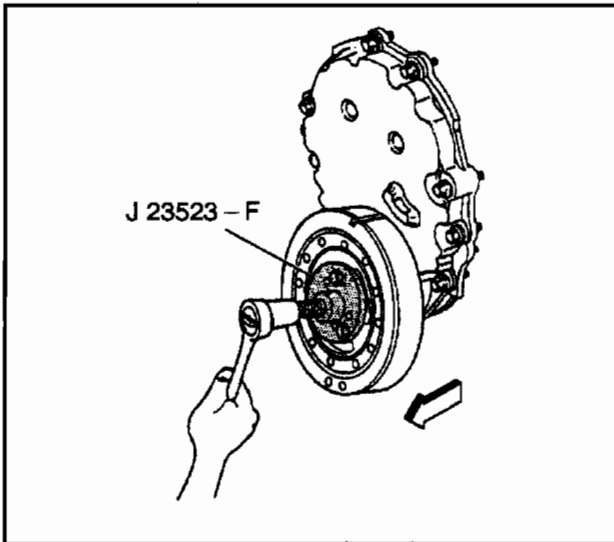


173172



188056

2. Remove the bolts and the crankshaft pulley.

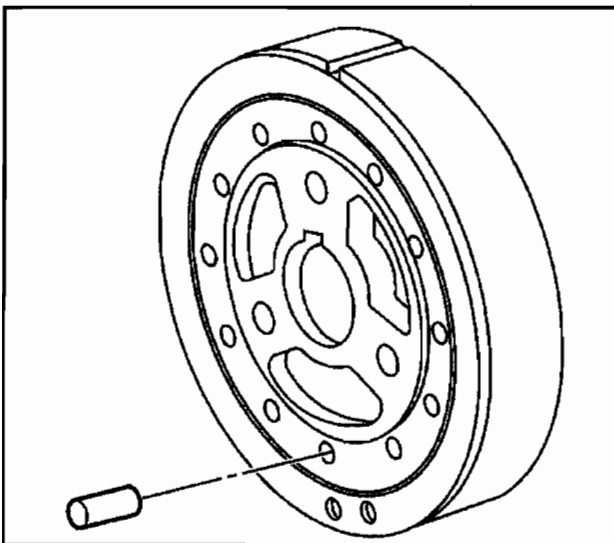


66878

Notice: Refer to *Fastener Notice* in Cautions and Notices.

3. Use the *J 23523-F* in order to remove the crankshaft balancer.
 - 3.1. Install the *J 23523-F* plate and bolts onto the crankshaft balancer.

Tighten
Tighten the bolts to 25 N·m (18 lb ft).
 - 3.2. Install the *J 23523-F* forcing screw into the plate.
 - 3.3. Rotate the *J 23523-F* forcing screw clockwise in order to remove the crankshaft balancer.
4. Remove the *J 23523-F* from the crankshaft balancer.



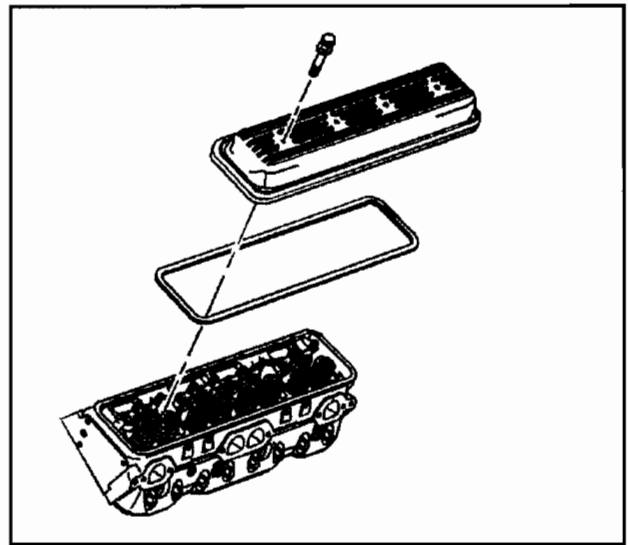
182849

5. Note the position and length of any front groove crankshaft balancer weight pins, if applicable.

Valve Rocker Arm Cover Removal - Left

SIE-ID = 650061

1. Remove the valve rocker arm cover bolts and washers.
2. Remove the valve rocker arm cover.
3. Remove the valve rocker arm cover gasket.
4. Discard the valve rocker arm cover gasket.

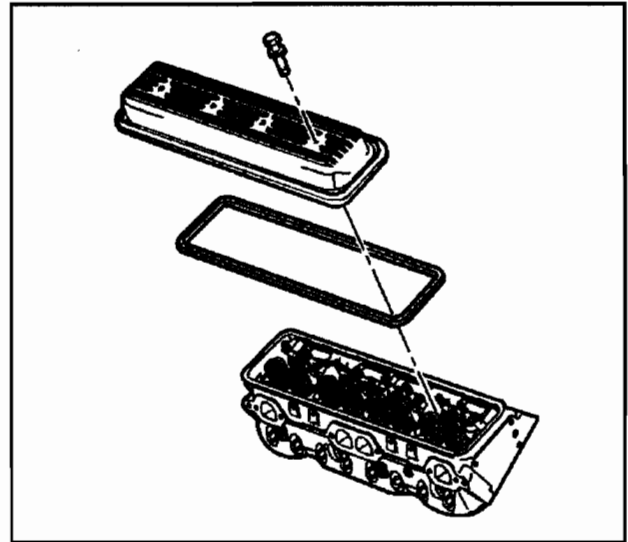


39119

Valve Rocker Arm Cover Removal - Right

SIE-ID = 650062

1. Remove the valve rocker arm cover bolts and washers.
2. Remove the valve rocker arm cover.
3. Remove the valve rocker arm cover gasket.
4. Discard the valve rocker arm cover gasket.

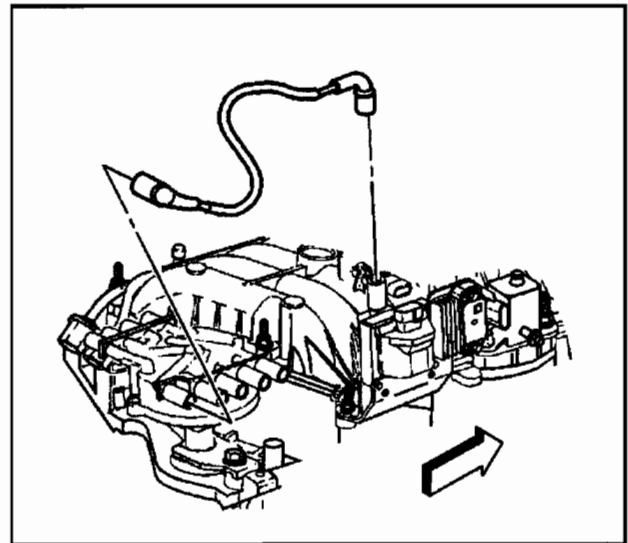


182833

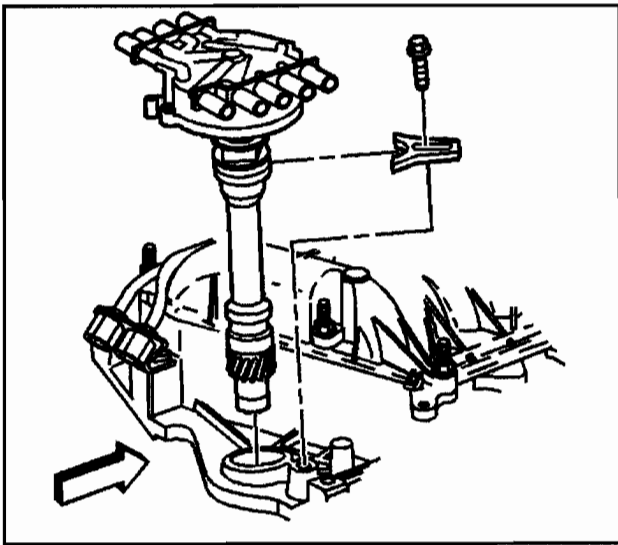
Distributor Removal

SIE-ID = 69504

1. Remove the ignition coil wire harness from the ignition coil and distributor cap.

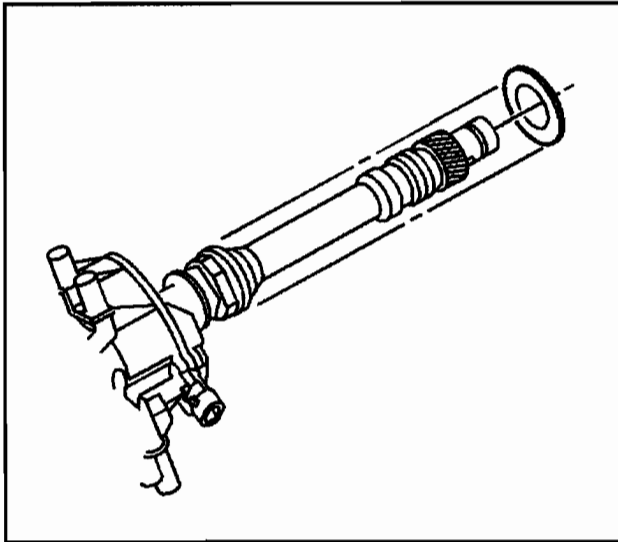


341359



69303

2. Remove the distributor clamp bolt.
3. Remove the distributor and the distributor clamp.



523516

4. Remove the distributor gasket and discard.

Intake Manifold Removal

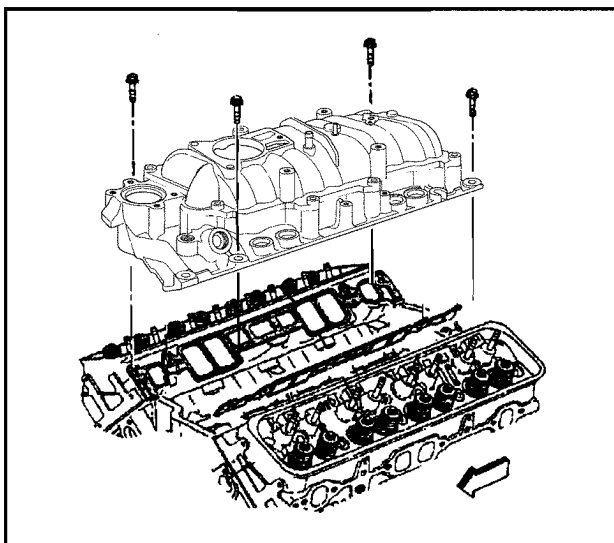
1. Remove the lower intake manifold bolts.

Important: The intake manifold may be removed as an assembly. Do not remove the specific intake manifold components unless component service is required.

Do not allow dirt or debris to enter the fuel system. Ensure that the ends of the fuel system are properly sealed.

Do not disassemble the Central Sequential Fuel Injection (SFI) unit, unless service is required.

2. Remove the intake manifold assembly.
3. Remove and discard the lower intake manifold gaskets.



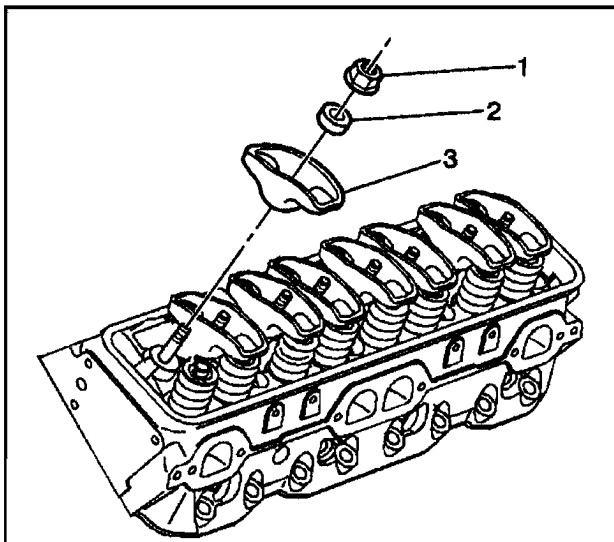
66456

Valve Rocker Arm and Push Rod Removal

SIE-ID = 66690

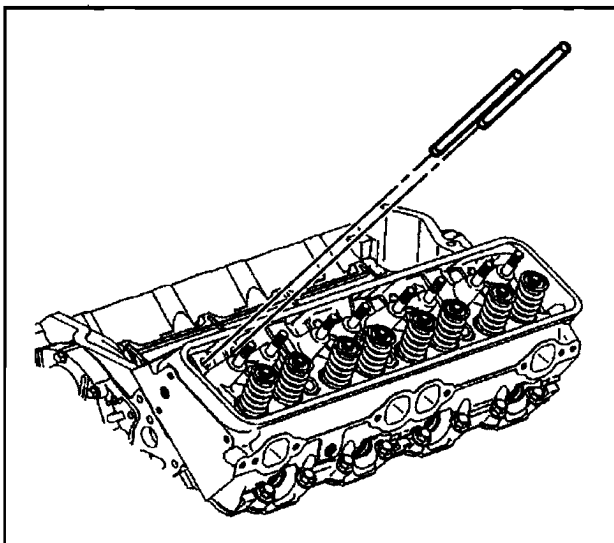
Important: Mark, sort, and organize the components so that the components can be reinstalled to the original location.

1. Remove the following components from the cylinder head:
 - 1.1. The valve rocker arm nuts (1)
 - 1.2. The valve rocker arm balls (2)
 - 1.3. The valve rocker arms (3)



182835

2. Remove the valve pushrods.

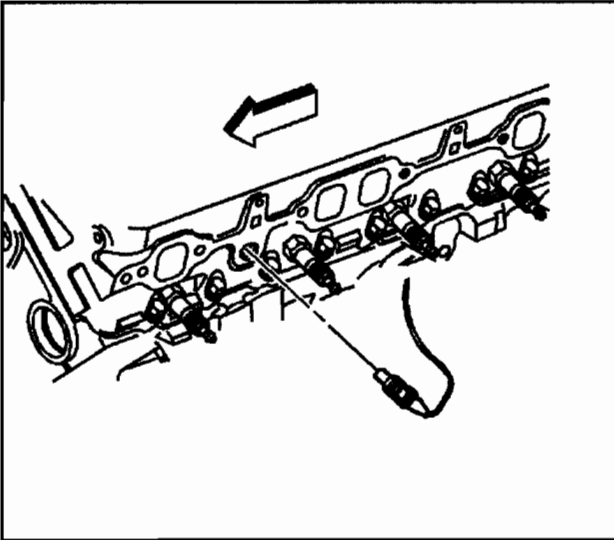


22766

Cylinder Head Removal - Left

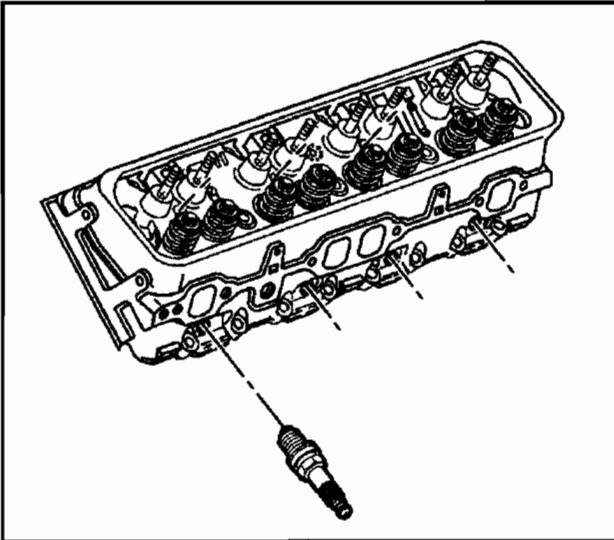
SIE-ID = 650064

1. Remove the engine coolant temperature gage sensor.



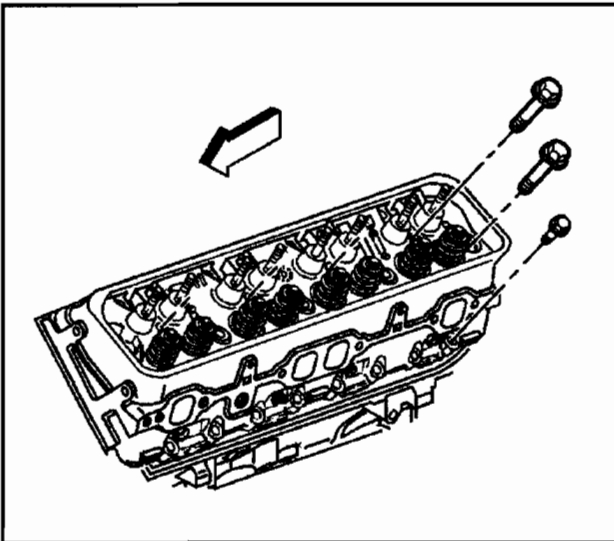
521828

2. Remove and discard the spark plugs.



317307

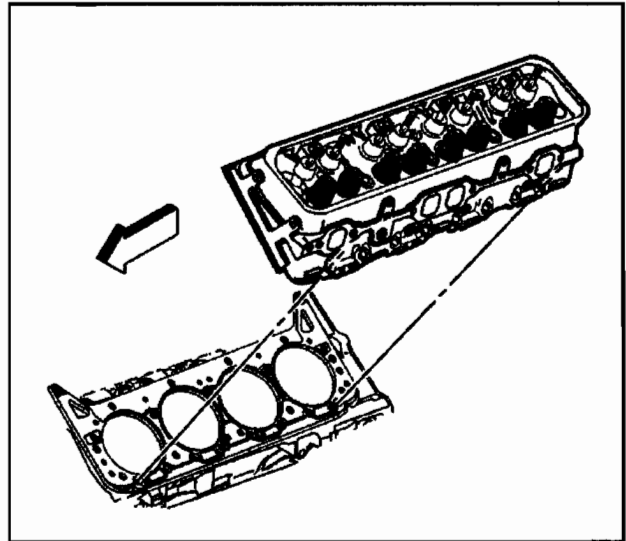
3. Remove the cylinder head bolts.



317217

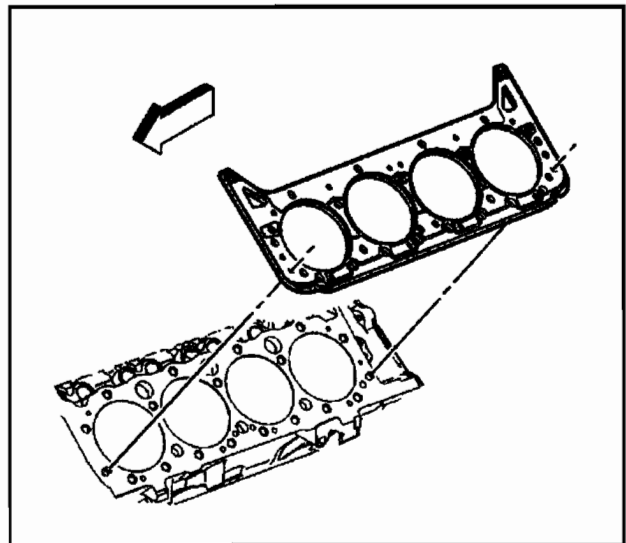
Notice: SIO-ID = 13838 After removal, place the cylinder head on two wood blocks to prevent damage.

4. Remove the cylinder head.



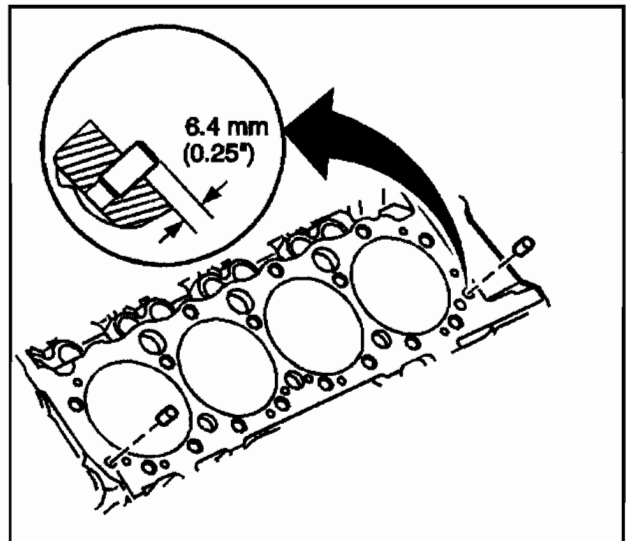
317227

5. Remove and discard the cylinder head gasket.

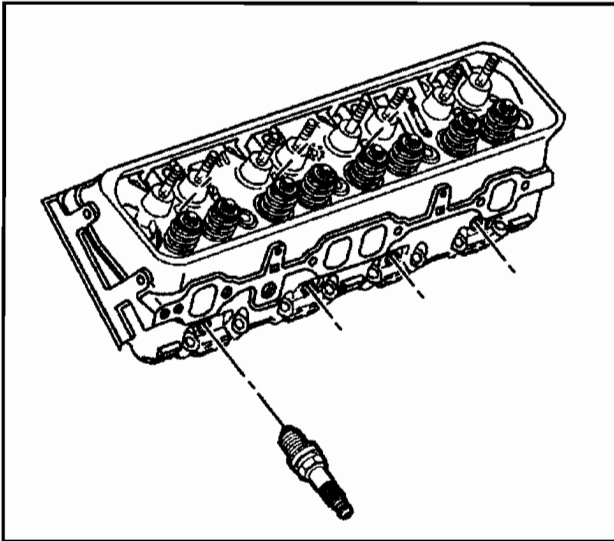


317233

6. Remove the cylinder head locator dowel pin, if required.



182846

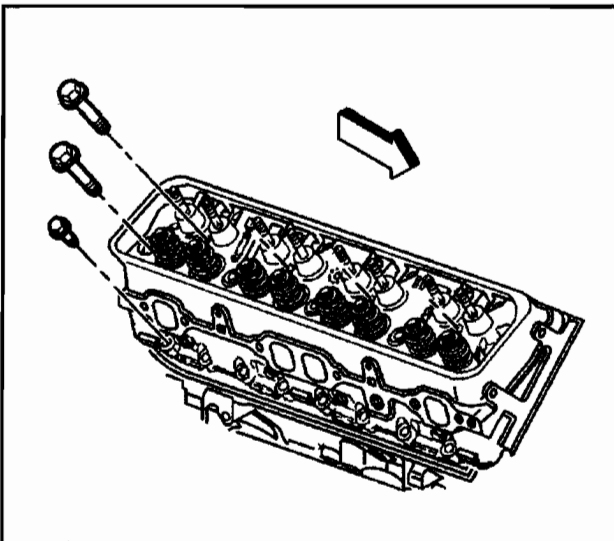


317307

Cylinder Head Removal - Right

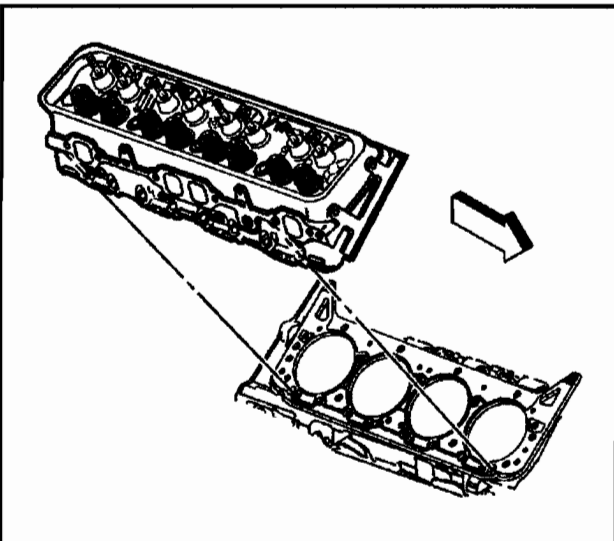
SIE-ID = 650065

1. Remove and discard the spark plugs.



317239

2. Remove the cylinder head bolts.

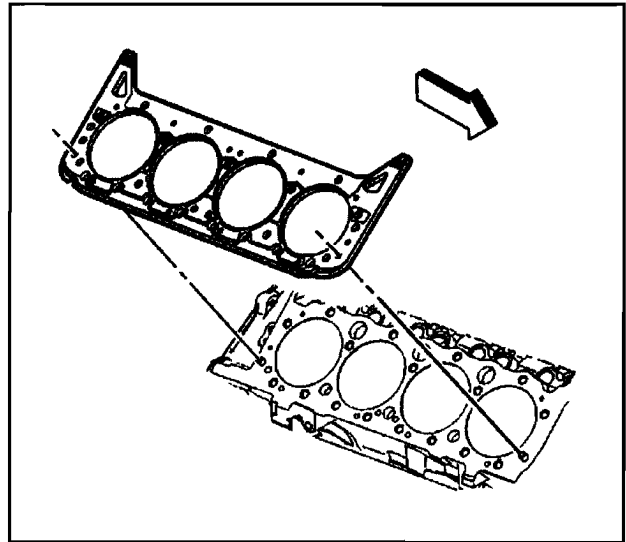


317246

Notice: SIO-ID = 13838 After removal, place the cylinder head on two wood blocks to prevent damage.

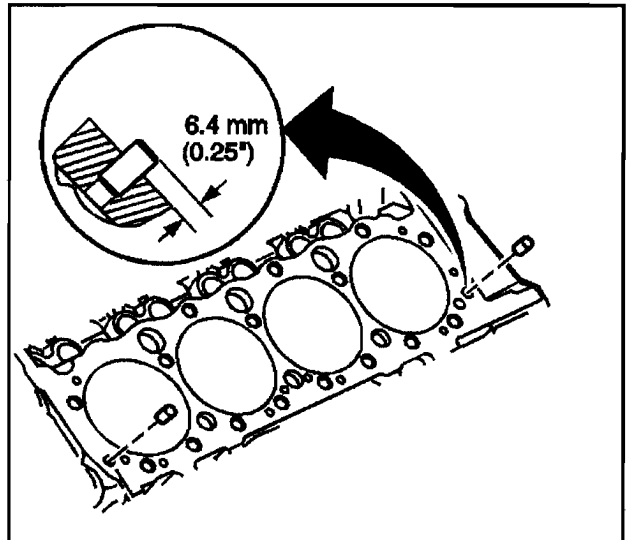
3. Remove the cylinder head.

- 4. Remove and discard the cylinder head gasket.



317255

- 5. Remove the cylinder head locator dowel pin, if required.



182846

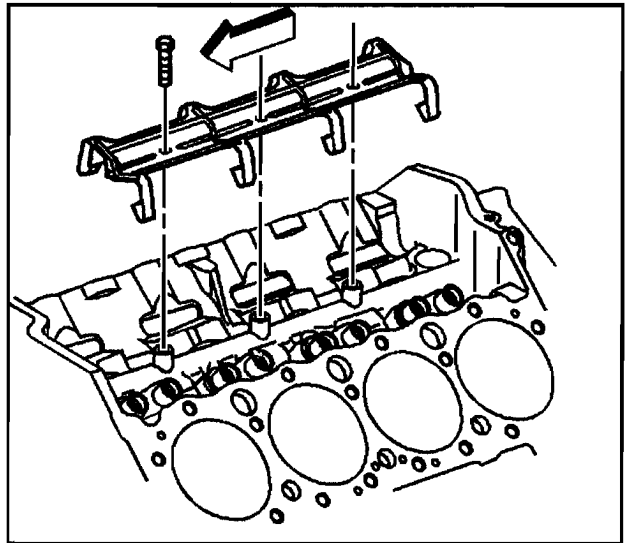
Valve Lifter Removal

SIE-ID = 24119

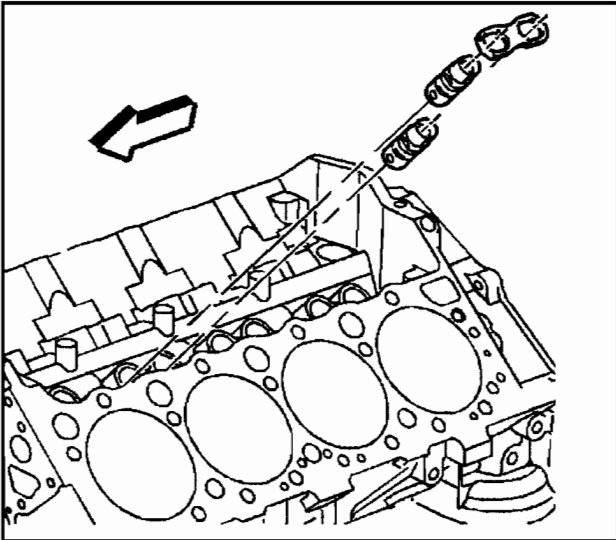
Tools Required

J 3049-A Valve Lifter Remover

- 1. Remove the bolts and valve lifter guide retainer.



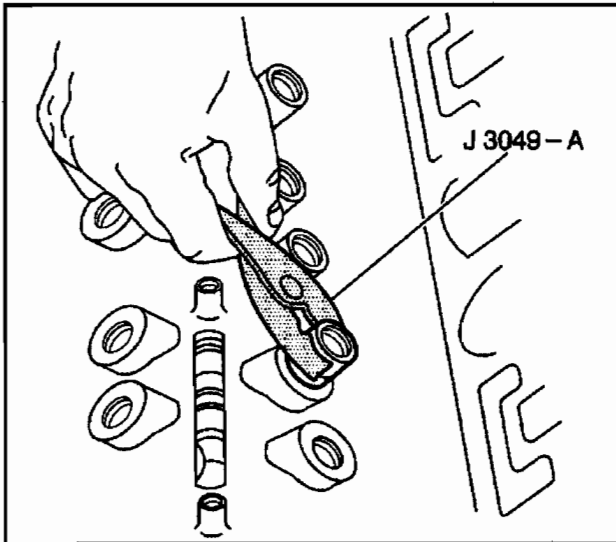
11508



11509

Important: Place the valve lifters in the rack in the upright position in order to maintain the oil inside the valve lifter.

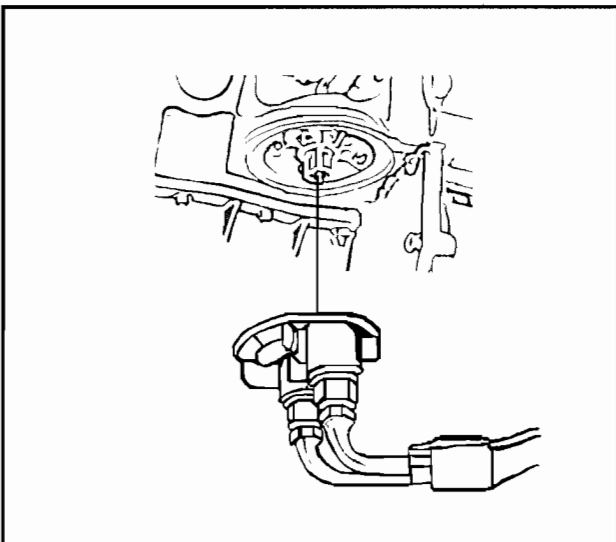
2. Remove the valve lifter guides and valve lifters.
3. Place the components in a rack so that the components can be reinstalled to the original location.



31350

Important: Some valve lifters may be stuck in the valve lifter bores because of gum or varnish deposits.

4. Use the *J 3049-A* in order to remove the stuck valve lifters.



39122

Oil Filter Adapter Removal

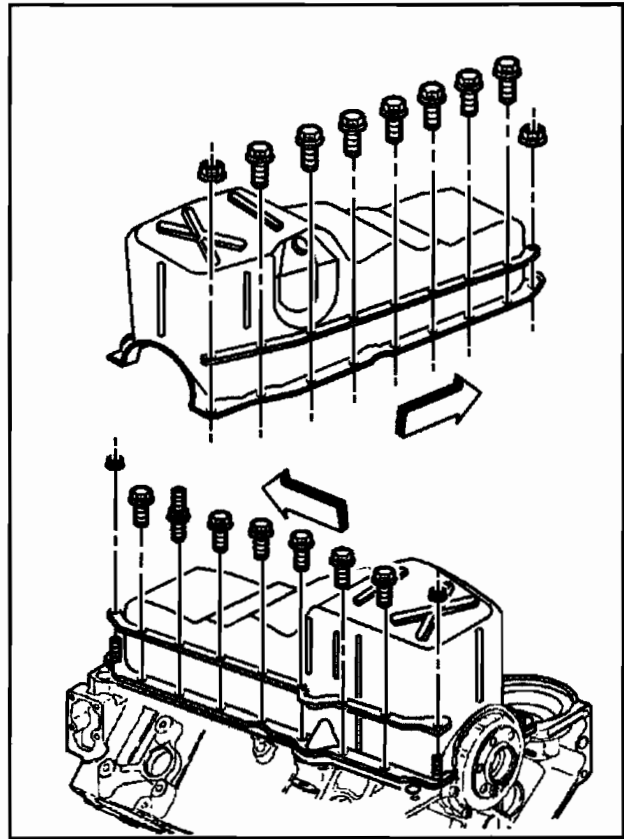
SIE-ID = 69505

1. Remove the oil filter adapter bolts and washers, if applicable.
2. Remove the oil filter adapter.
 - If equipped with a remote oil filtration system, then
 1. Remove the oil hoses.
 - Center hose (oil flows in)
 - Outer hose (oil flows out)
 2. Unscrew the oil bypass adapter, if applicable.
3. Remove the oil filter adapter seal, O-ring, and the oil filter adapter gasket, if applicable.
4. Discard the oil filter adapter seal, O-ring, and the oil filter adapter gasket, if applicable.

Oil Pan Removal

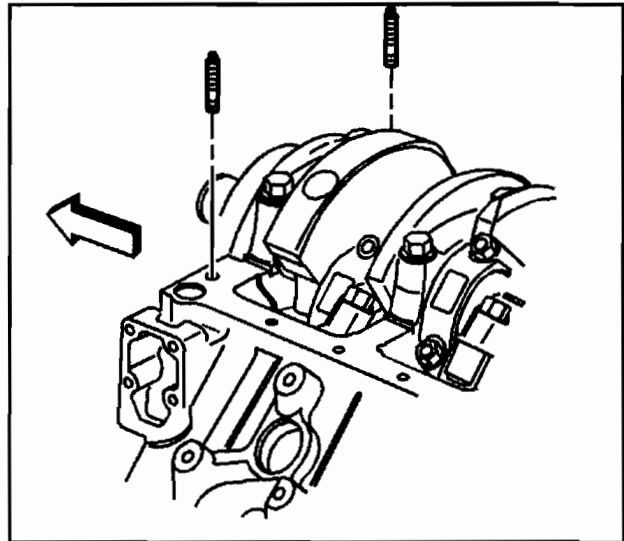
SIE-ID = 66836

1. Remove the oil pan bolts and nuts.
2. Remove the oil pan reinforcements.
3. Remove the oil pan.
4. Remove and discard the oil pan gasket.

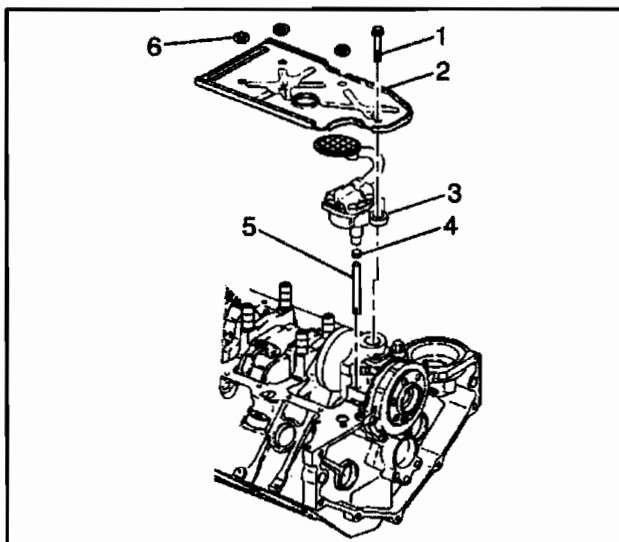


182851

5. Remove the oil pan studs.



521817



11438

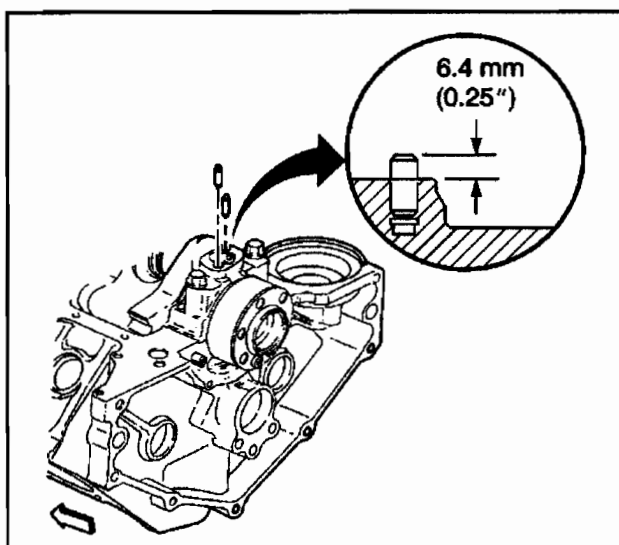
Oil Pump, Pump Screen and Deflector Removal

SIE-ID = 195387

1. Remove the nuts (6) and the crankshaft oil deflector (2).
2. Remove the oil pump bolt (1).
3. Remove the oil pump (3), the oil pump driveshaft (5), and the oil pump driveshaft retainer (4).
4. Separate the oil pump (3), the oil pump driveshaft (5), and the oil pump driveshaft retainer (4).

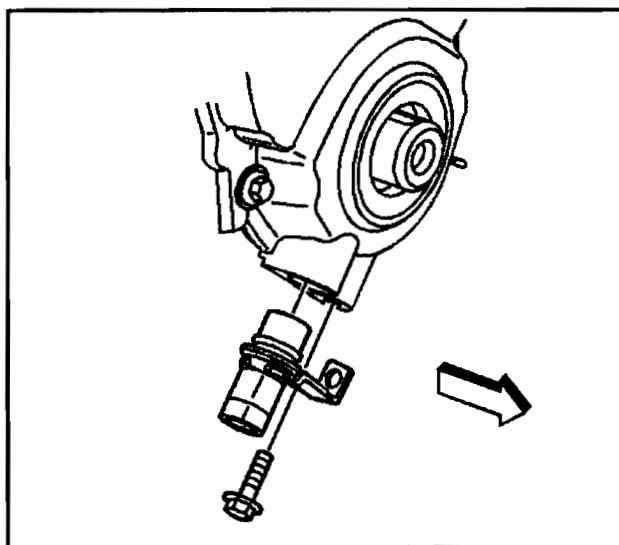
Important: Always install a NEW oil pump driveshaft retainer during assembly.

5. Discard the oil pump driveshaft retainer.



182852

6. Inspect the oil pump locator pins for damage. Replace the pins if required.



11485

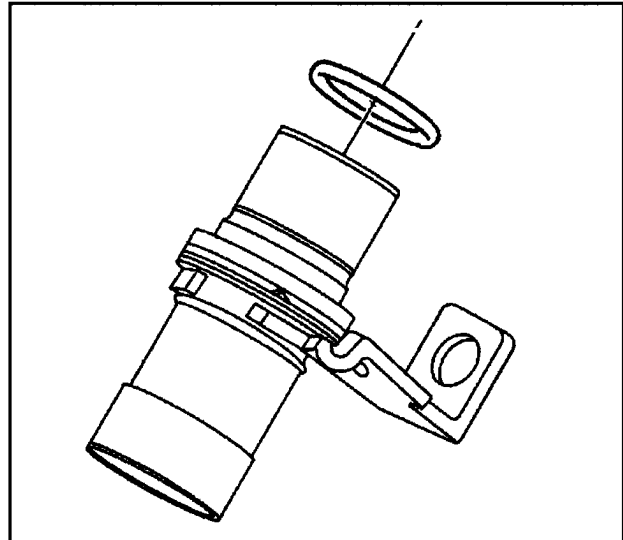
Engine Front Cover Removal

SIE-ID = 195381

1. Remove the crankshaft position sensor bolt.
2. Remove the crankshaft position sensor.

Important: Always install a NEW crankshaft position sensor seal, O-ring, during assembly.

3. Remove the crankshaft position sensor seal, O-ring.
4. Discard the crankshaft position sensor seal, O-ring.

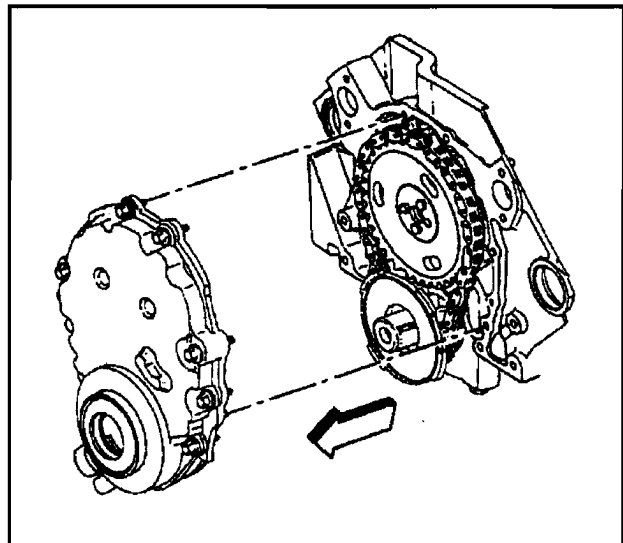


387759

5. Remove the engine front cover bolts.
6. Remove the engine front cover and gasket.

Important: DO NOT reuse the composite engine front cover and gasket. Always install a NEW engine front cover.

7. Discard the engine front cover and gasket.



69010

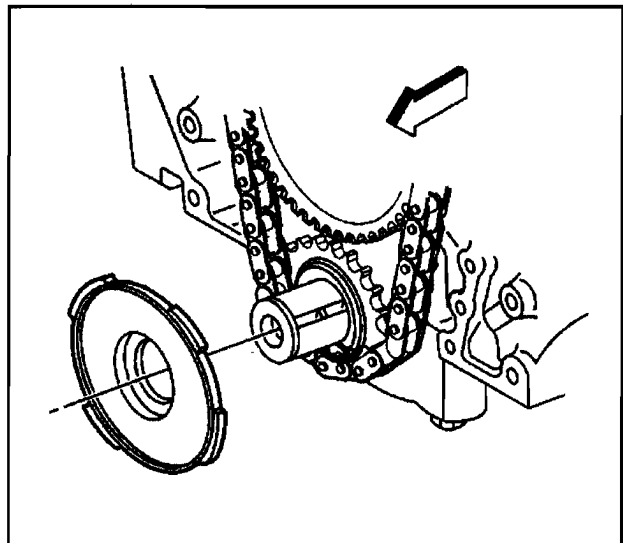
Timing Chain and Sprockets Removal

SIE-ID = 66838

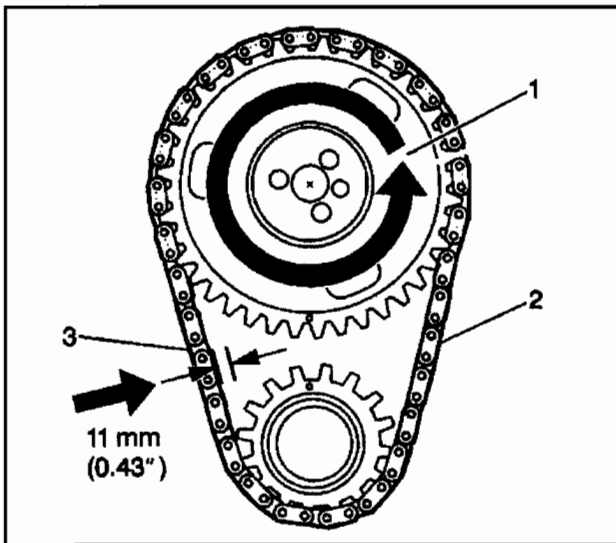
Tools Required

J 5825-A Crankshaft Gear Remover

1. Remove the crankshaft position sensor reluctor ring.

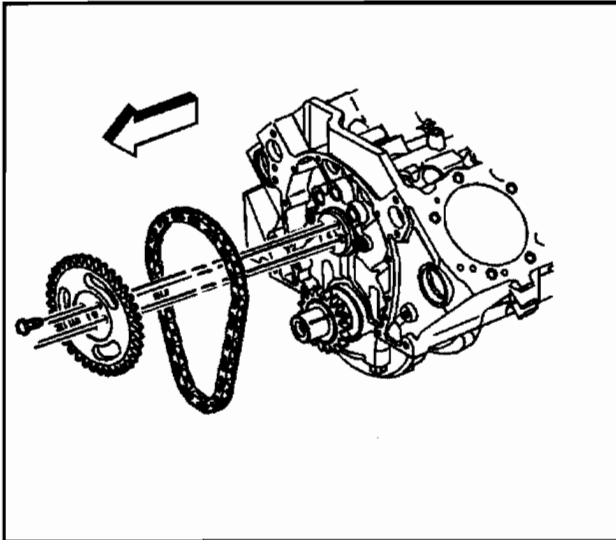


69450



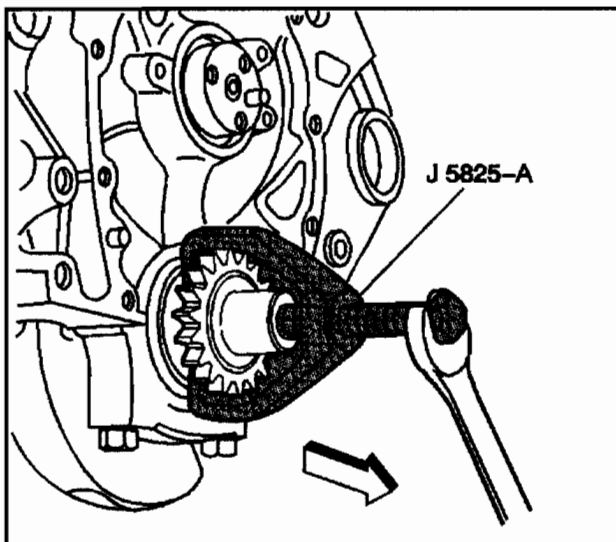
341357

2. Check the camshaft timing chain free play. If the camshaft timing chain can be moved in excess of 11 mm (0.43 in), replacement of the camshaft timing chain and the sprockets is recommended during assembly.
 - 2.1. Rotate the camshaft sprocket (1) counterclockwise until all slack is removed from the camshaft timing chain (2).
 - 2.2. Measure the free play on the slack side (3) of the camshaft timing chain.



500645

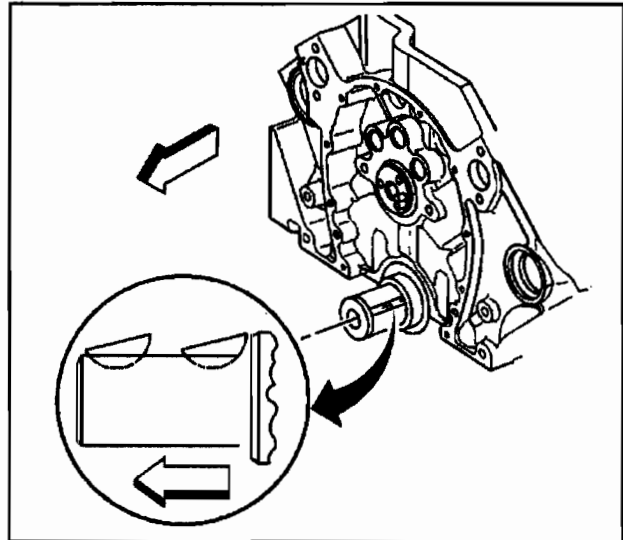
3. Remove the camshaft sprocket bolts.
4. Remove the camshaft sprocket.
5. Remove the camshaft timing chain.



11506

6. Remove the crankshaft sprocket using the J 5825-A.

7. Remove the crankshaft balancer woodruff keys, if required.

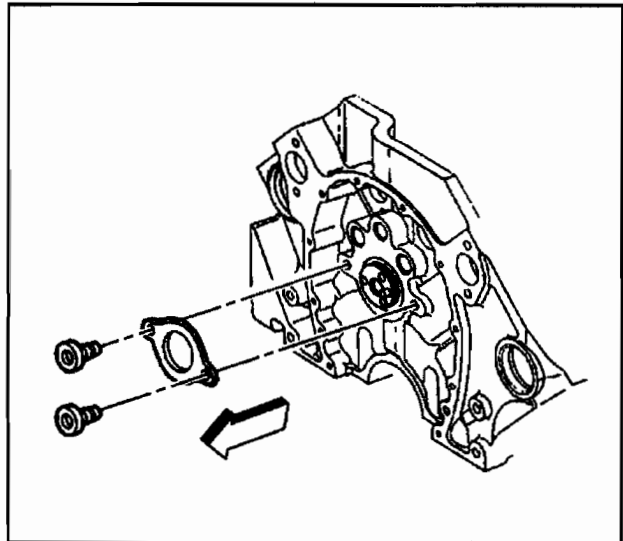


182847

Camshaft Removal

SIE-ID = 69031

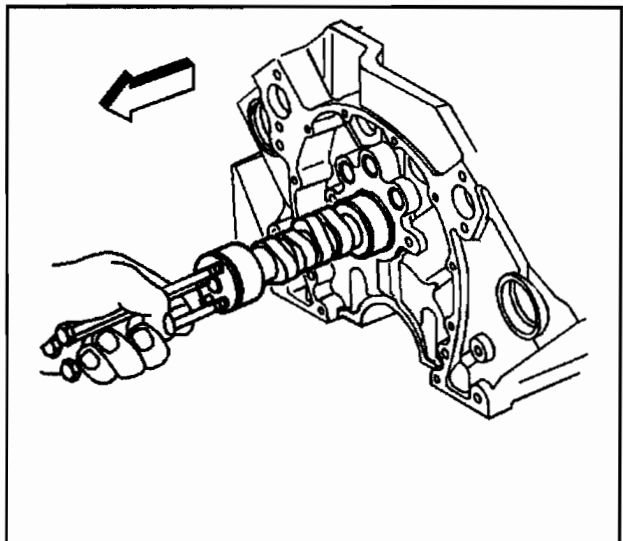
1. Remove the bolts and the camshaft retainer.



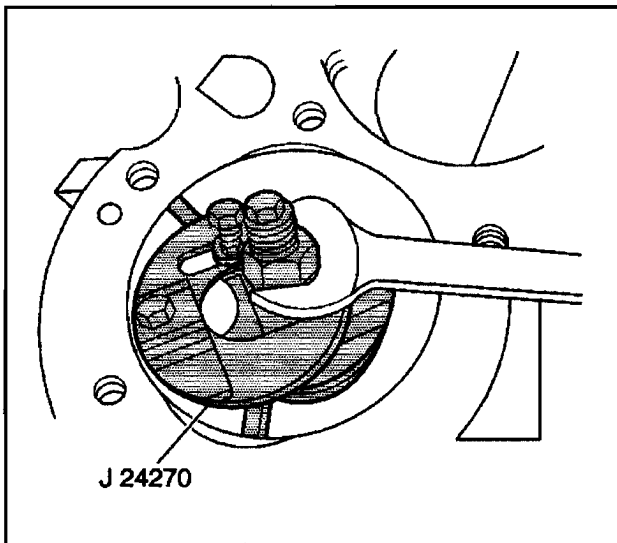
182836

Notice: SIO-ID = 13833 All camshaft journals are the same diameter, so care must be used in removing or installing the camshaft to avoid damage to the camshaft bearings.

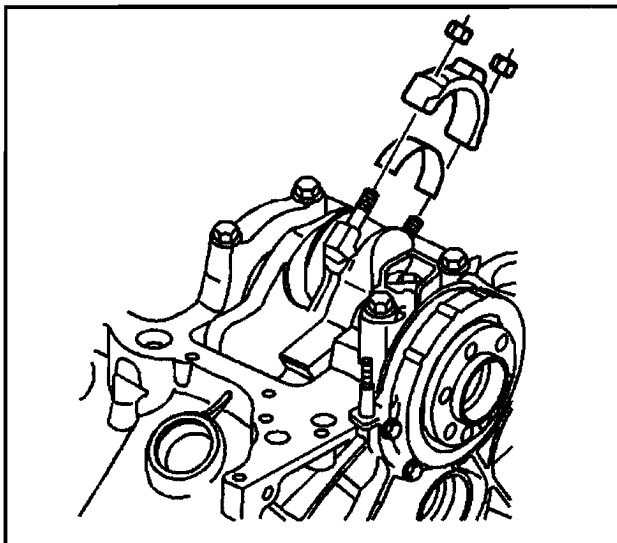
2. Remove the engine camshaft.
 - 2.1. Install the three 5/16-18 x 4.0 inch bolts in the engine camshaft front bolt holes.
 - 2.2. Using the bolts as a handle, carefully rotate and pull the engine camshaft out of the camshaft bearings.
 - 2.3. Remove the bolts from the front of the engine camshaft.



69013



11497



480549

Piston, Connecting Rod, and Bearing Removal

SIE-ID = 24200

Tools Required

- J 5239 Connecting Rod Bolt Guide Set
- J 24270 Cylinder Bore Ridge Reamer

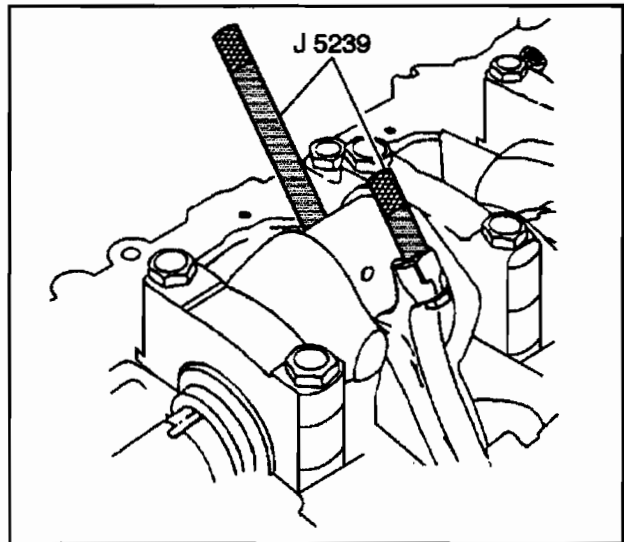
Caution: Refer to *Safety Glasses Caution in Cautions and Notices*.

1. Remove the ring ridge.
 - 1.1. Turn the crankshaft until the piston is at the bottom of the stroke.
 - 1.2. Place a cloth on the top of the piston.
 - 1.3. Use the J 24270 in order to remove cylinder ring ridge.
 - 1.4. Turn the crankshaft so the piston is at the top of the stroke.
 - 1.5. Remove the cloth.
 - 1.6. Remove the cutting debris.

Important: Place matchmarks or numbers on the connecting rods and the connecting rod caps.

2. Remove the connecting rod nuts.
3. Remove the connecting rod cap.

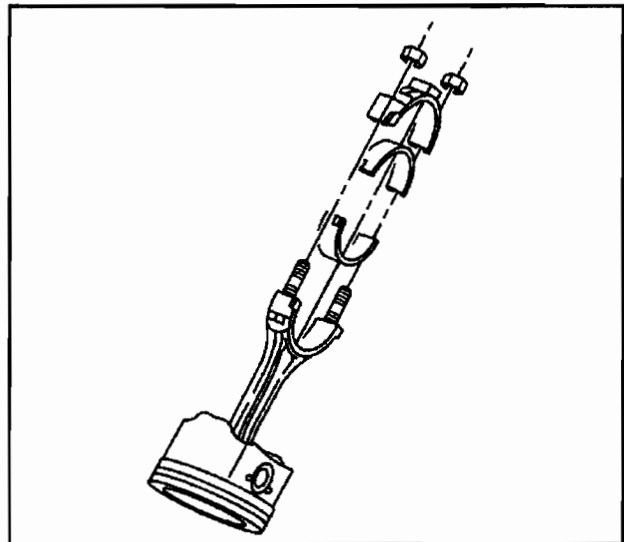
4. Use the *J 5239* in order to protect the crankshaft journals and remove the connecting rod and the piston out of the top of the engine block.



31373

Important: Always assemble the connecting rod caps to the matching connecting rods.

5. Remove the connecting rod bearings.
 - Keep the connecting rod bearings with the original connecting rod and connecting rod cap.
 - Wipe the oil from the connecting bearings.
 - Wipe the oil from the crankpins.

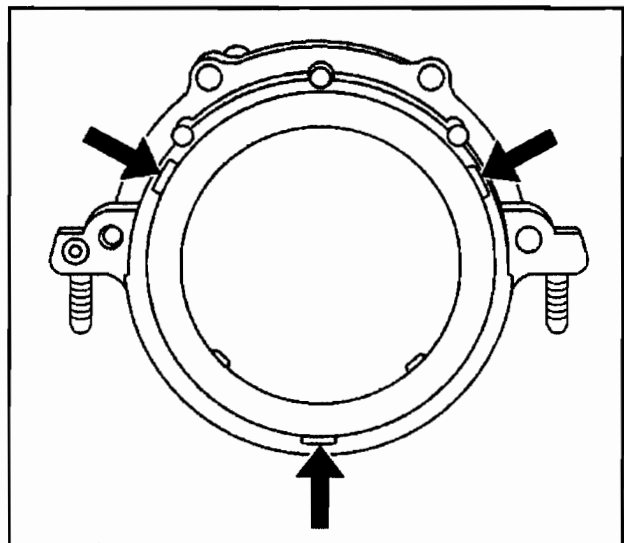


188017

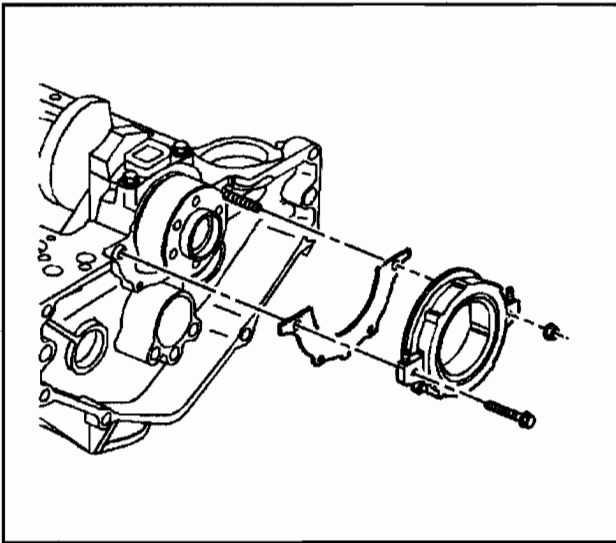
Crankshaft Rear Oil Seal and Housing Removal

SIE-ID = 24222

1. Remove the crankshaft rear oil seal from the crankshaft rear oil seal housing.
 Insert a suitable tool into the access notches and then carefully pry the crankshaft rear oil seal from the crankshaft rear oil seal housing.
2. Discard the crankshaft rear oil seal.

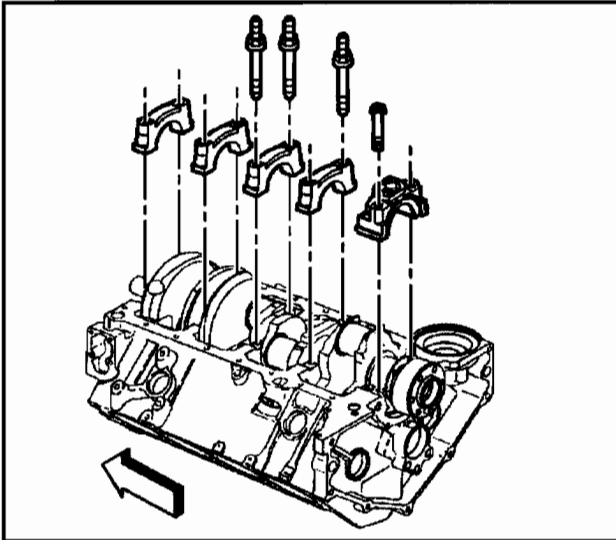


31379



11479

3. Remove the crankshaft rear oil seal housing nut and bolts.
4. Remove the crankshaft rear oil seal housing.
5. Remove the crankshaft rear oil seal housing gasket.
6. Discard the crankshaft rear oil seal housing gasket.
7. Remove the rear oil seal housing retainer stud from the engine block.

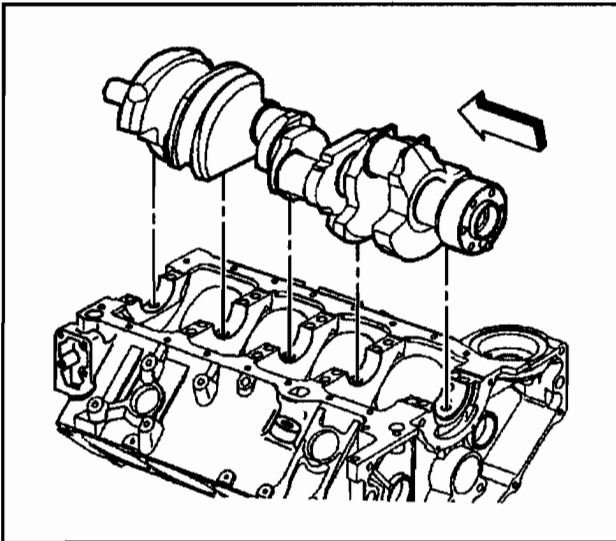


317268

Crankshaft and Bearings Removal

SIE-ID = 69426

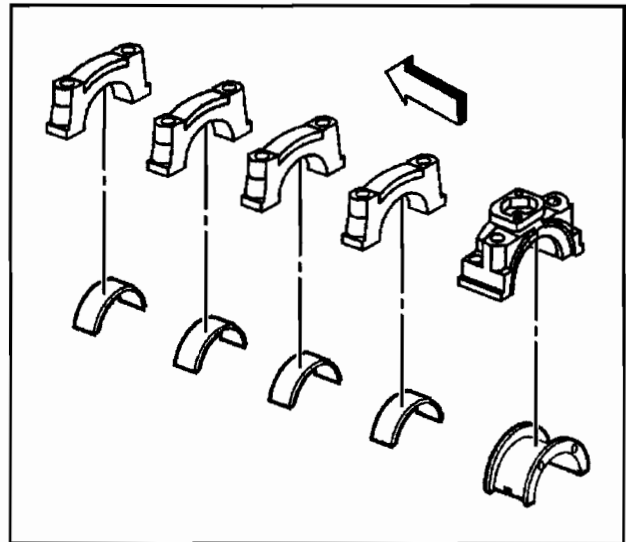
1. Mark or identify the crankshaft bearing cap locations and positions for assembly.
2. Remove the crankshaft bearing cap bolts and studs.
3. Remove the crankshaft bearing caps.



317351

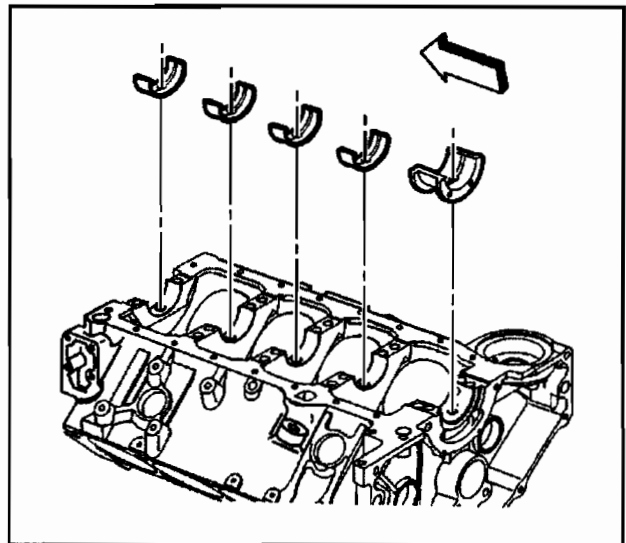
4. Remove the crankshaft.

- Remove the crankshaft bearings from the crankshaft bearing caps.



317295

- Remove the crankshaft bearings from the engine block.



317292

Engine Block Plug Removal

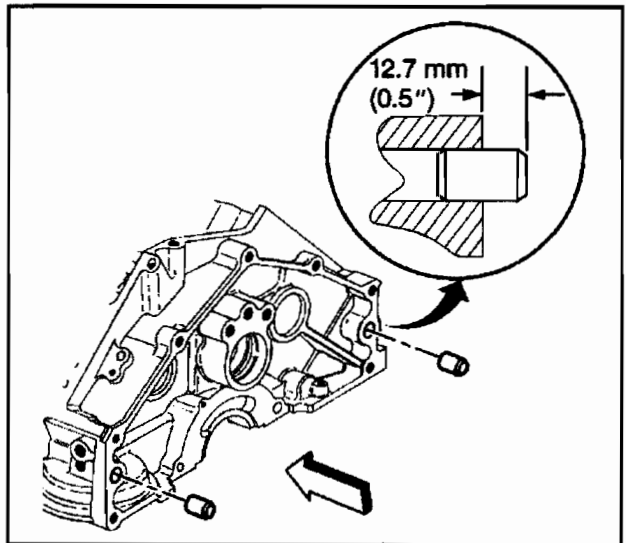
SIE-ID = 348910

Tools Required

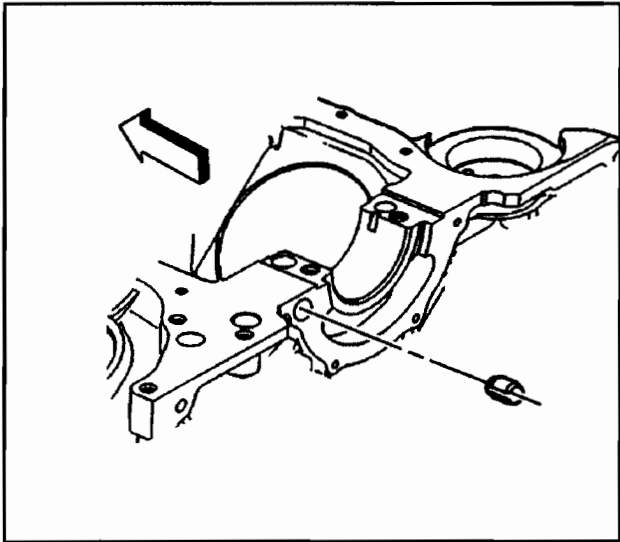
J 41712 Oil Pressure Switch Socket

Caution: Refer to Safety Glasses Caution in Cautions and Notices.

- Remove the transmission locator pins, if required.

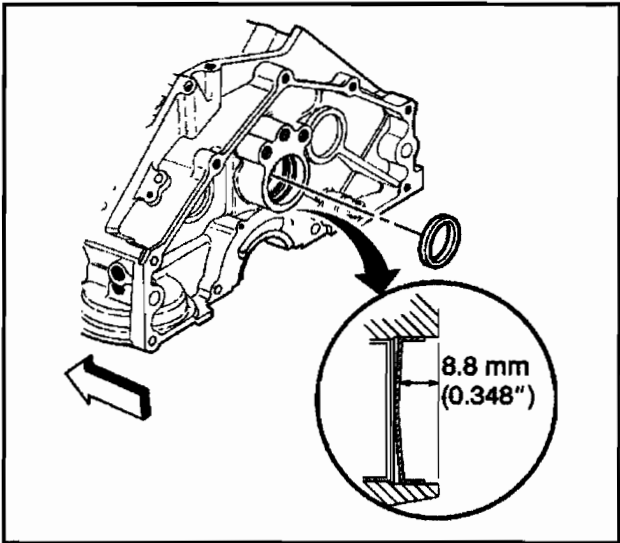


182855



521820

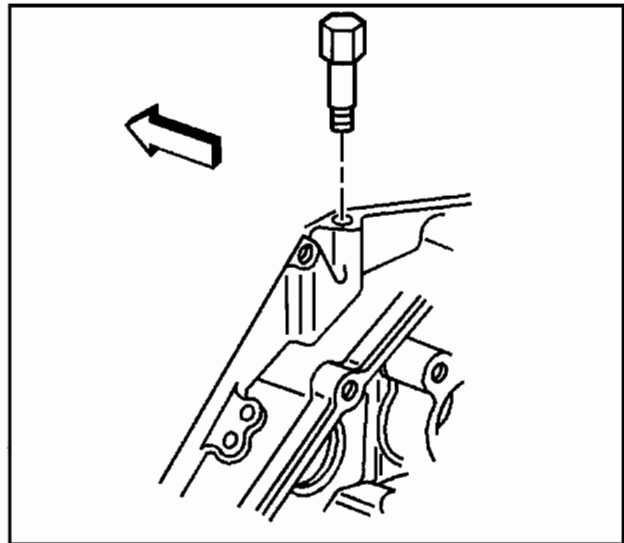
2. Remove the S type pin, and the crankshaft rear oil seal housing, if required.



182854

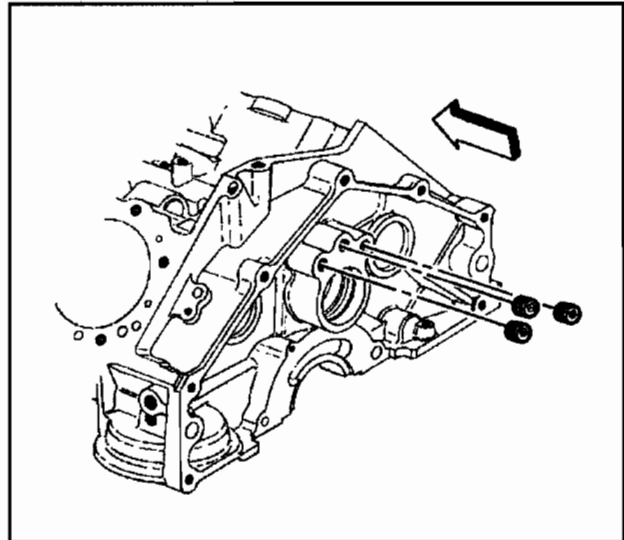
3. Remove the expansion cup plug from the camshaft rear bearing hole.

- 5. Remove the engine oil pressure sensor gage sensor fitting.



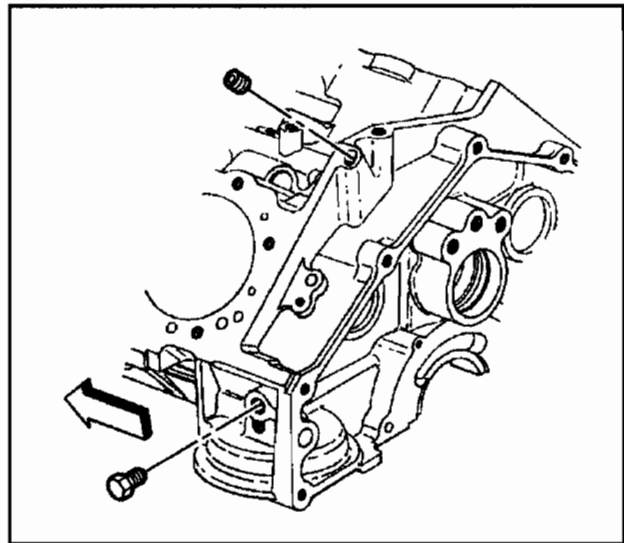
333652

- 6. Remove the engine block oil gallery plugs from the rear of the engine block and discard.

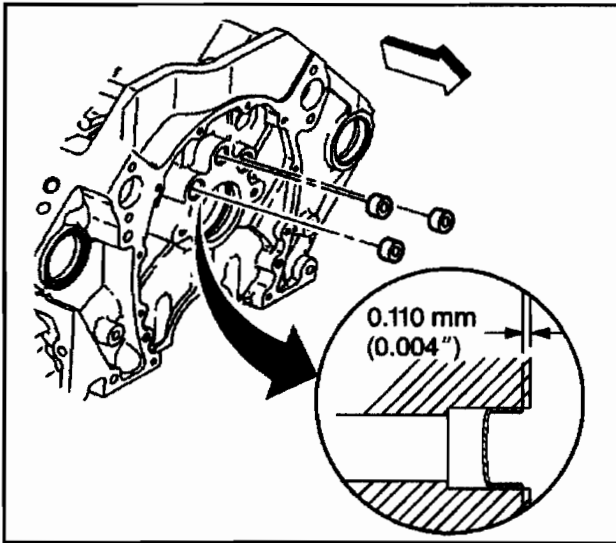


69847

- 7. Remove the left side rear and left rear top engine block oil gallery plugs.

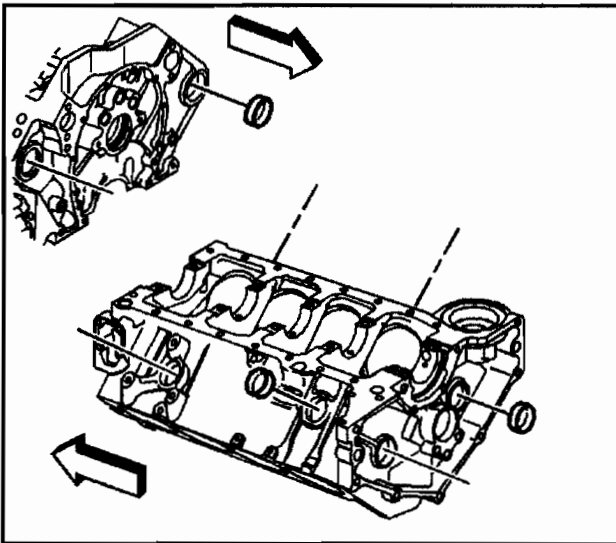


182841



182838

8. Remove the engine block oil gallery plugs from the front of the engine block and discard.
Insert a 3/8 x 26 inch rod into the rear oil gallery holes in order to drive out the front engine block oil gallery plugs.



500648

9. Remove the engine block core hole plugs.
 - 9.1. Use a suitable tool in order to drive the engine block core hole plug into the coolant jacket.
 - 9.2. Use a suitable tool in order to pull the engine block core hole plug from the coolant jacket.
 - 9.3. Discard the engine block core hole plug.

Engine Block Cleaning and Inspection

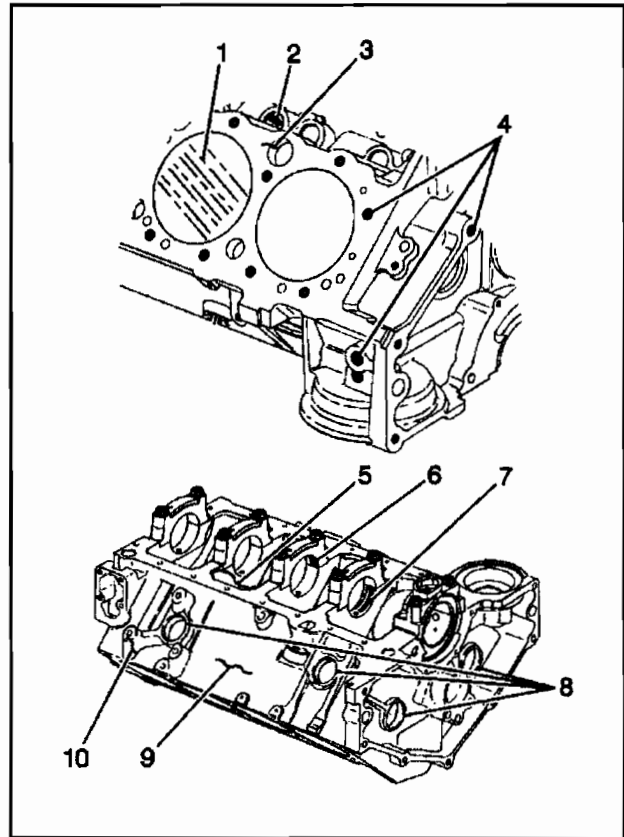
SIE-ID = 784233

Tools Required

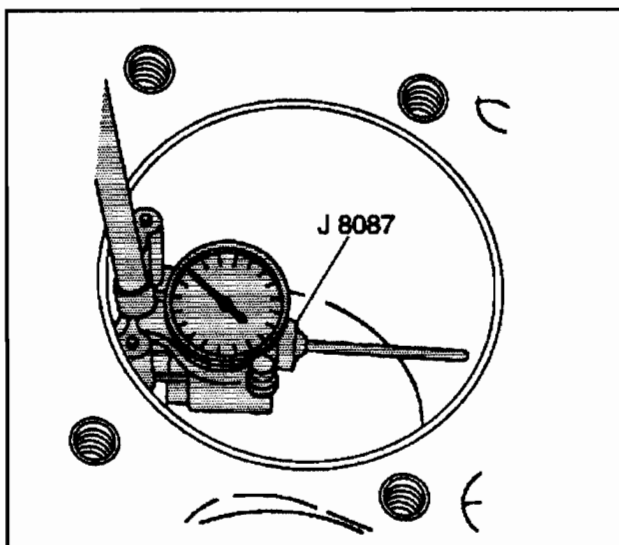
J 8087 Cylinder Bore Gage

Caution: Refer to Safety Glasses Caution in Cautions and Notices.

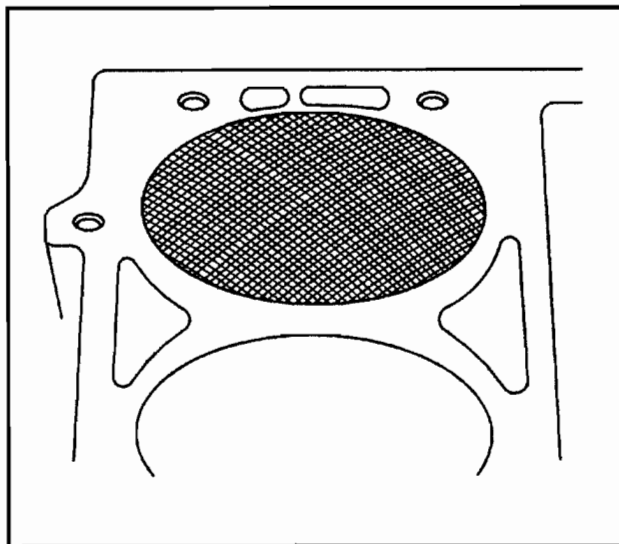
1. Clean all the remaining sealing or gasket material from the sealing surfaces.
2. Clean the engine block in cleaning solvent.
3. Flush the engine block with clean water or steam.
4. Clean the cylinder bores.
5. Clean the oil galleries and the oil passages.
6. Clean the scale and the deposits from the coolant passages.
7. After cleaning the engine block, spray or wipe the cylinder bores and the machined surfaces with clean engine oil.
8. Inspect the following areas:
 - Cylinder bores (1) for scratches or gouging
 - Valve lifter bores (2) for excessive scoring or wear
 - Coolant jackets (3) for cracks
 - Threaded holes (4) for damage
 - Crankshaft bearing webs (5) for cracks
 - Crankshaft bearing caps (6) and the crankshaft bearing bores (7) for damage
 - The crankshaft bearing bores should be round and uniform when measuring the inside diameter (ID).
 - The surface where the crankshaft bearings contact the crankshaft bearing bore should be smooth.
 - If a crankshaft bearing cap is damaged and requires replacement, replace the crankshaft bearing cap first. Then rebores the engine block crankshaft bearing bores and check for the proper alignment. Finally, check the crankshaft bearings for the proper clearances.
 - Expansion cup plug bores (8) for damage
 - Engine block (9) for cracks or damage
 - Engine mount bosses (10) for damage



317297



4972



186747

9. Measure the cylinder bores for taper and out-of-round.

- 9.1. Depress the plunger on the *J 8087* 7 mm (0.275 in) or until the *J 8087* enters the cylinder bore.
- 9.2. Center the *J 8087* in the cylinder bore and turn the indicator dial to 0.
- 9.3. Move the *J 8087* up and down the cylinder bore to determine the taper. Refer to *Engine Mechanical Specifications (5.0 L)* or *Engine Mechanical Specifications (5.7 L)*.
- 9.4. Turn the *J 8087* to different points around the cylinder bore to determine the out-of-round condition. Refer to *Engine Mechanical Specifications (5.0 L)* or *Engine Mechanical Specifications (5.7 L)*.

Cylinder Boring and Honing

SIE-ID = 784235

Honing Procedure

Caution: Refer to *Safety Glasses Caution in Cautions and Notices*.

1. When honing the cylinder bores, follow the manufacturer's recommendations for equipment use, cleaning, and lubrication.
 - Use only clean sharp stones of the proper grade for the amount of material to be removed.
 - Dull, dirty stones cut unevenly and generate excessive heat.
 - DO NOT hone to a final grade with a coarse or medium-grade stone.
 - Leave sufficient metal so that all the stone marks will be removed with the fine grade stones.
 - Perform the final honing with a fine-grade stone and hone the cylinder bore in a cross hatch pattern at 45–65 degrees to obtain the proper clearance.
2. During the honing operation, thoroughly check the cylinder bore.
 - Repeatedly check the cylinder bore fit with the selected piston.
 - All measurements of the piston or cylinder bore should be made with the components at normal room temperature.
3. When honing to eliminate taper in the cylinder bore, use full strokes the complete length of the cylinder bore.

Repeatedly check the measurement at the top, the middle, and the bottom of the cylinder bore.

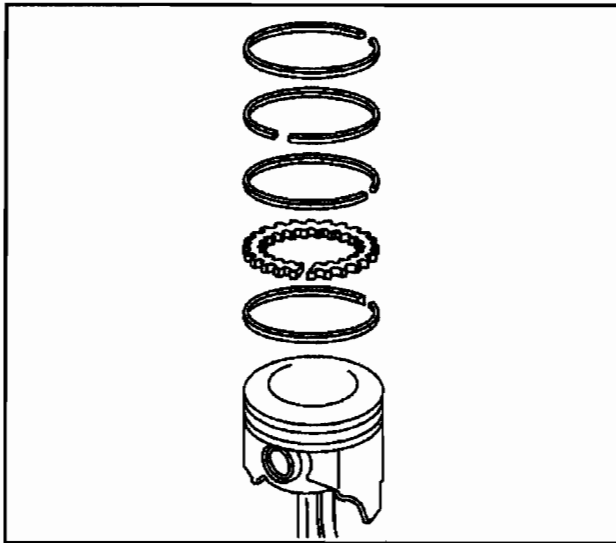
 - The finish marks should be clean but not sharp.

- The finish marks should be free from imbedded particles or torn or folded metal.
4. When finished, the reconditioned cylinder bores should have less than or meet the specified out-of-round and taper requirements.
 5. After the final honing and before the piston is checked for fit, clean the cylinder bore with hot water and detergent.
 - 5.1. Scrub the cylinder bores with a stiff bristle brush.
 - 5.2. Rinse the cylinder bores thoroughly with clean hot water.
 - 5.3. Dry the cylinder bores with a clean rag.
 - 5.4. Do not allow any abrasive material to remain in the cylinder bores.
 - Abrasive material may cause premature wear of the new piston rings and the cylinder bores.
 - Abrasive material will contaminate the engine oil and may cause premature wear of the bearings.
 6. Perform final measurements of the piston and the cylinder bore.
 7. Permanently mark the top of the piston for the specified cylinder to which it has been fitted.
 8. Apply clean engine oil to each cylinder bore in order to prevent rusting.

Boring Procedure

Caution: Refer to Safety Glasses Caution in Cautions and Notices.

1. Before starting the honing or reboring operation, measure all the new pistons with the micrometer contacting at points exactly 90 degrees from the piston pin centerline.
2. File the top of the cylinder block in order to remove any dirt or burrs before using any type of boring bar.
3. Follow the instructions furnished by the manufacturer regarding use of the boring equipment.
4. When reboring the cylinders, make sure all the crankshaft bearing caps are installed in the original position and direction.
5. Tighten the crankshaft bearing caps to the proper torque specifications in order to avoid distortion of the cylinder bores in the final assembly.
6. When making the final cut with the boring bar, leave 0.03 mm (0.001 in) on the cylinder bore diameter for finish honing. This gives the required position to the cylinder clearance specifications. Carefully perform the honing and boring operation in order to maintain the specified clearances between the pistons, the piston rings, and the cylinder bores.



4967

Piston and Connecting Rod Disassemble

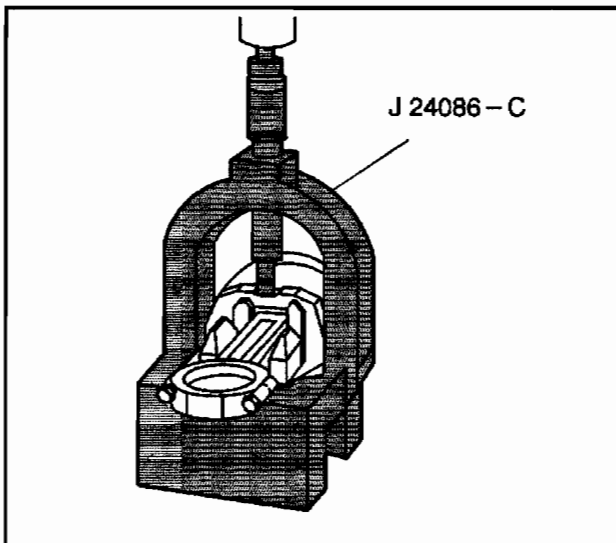
SIE-ID = 195087

Tools Required

J 24086-C Piston Pin Remover/Installer

Caution: Refer to *Safety Glasses Caution in Cautions and Notices.*

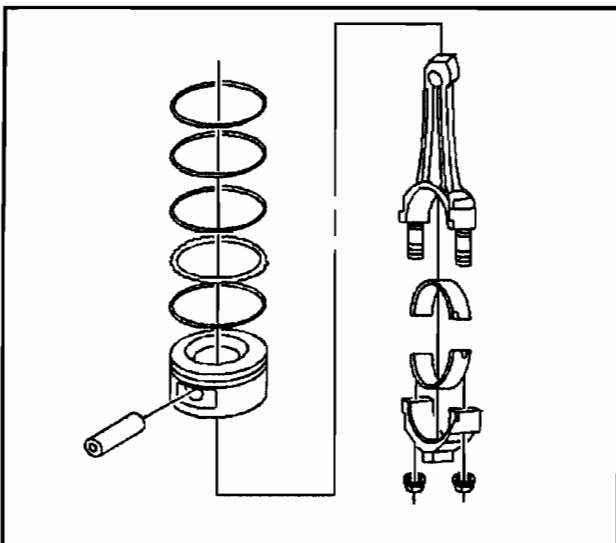
1. Remove the piston rings from the pistons.



4965

2. Press the piston pin from the connecting rod using the *J 24086-C*.

The piston pin has an interference fit into the connecting rod, and is full floating in the piston.



34671

3. Mark, separate, and organize the parts for assembly.

**Piston, Connecting Rod, and Bearings
Cleaning and Inspection**

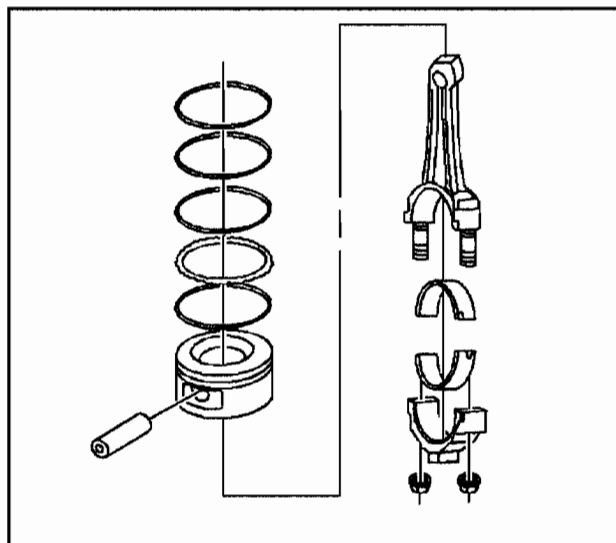
SIE-ID = 784237

Caution: Refer to Safety Glasses Caution in Cautions and Notices.

Important: Measurement of all the components should be taken with the components at room temperature.

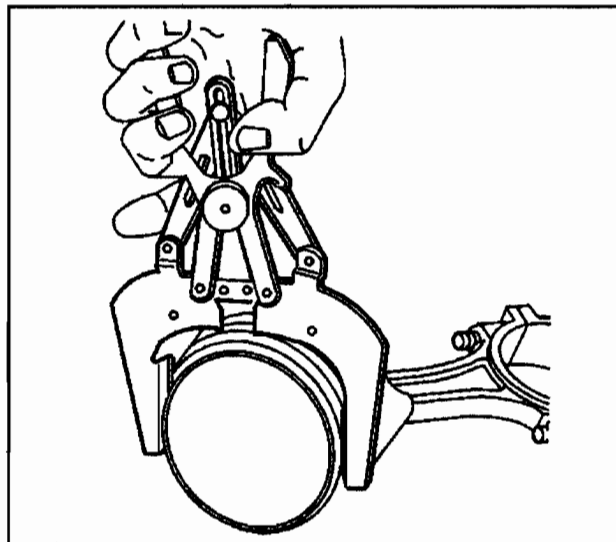
Do not use a wire brush in order to clean any part of the piston.

1. Clean the piston and connecting rod in cleaning solvent.
2. Dry the components with compressed air.



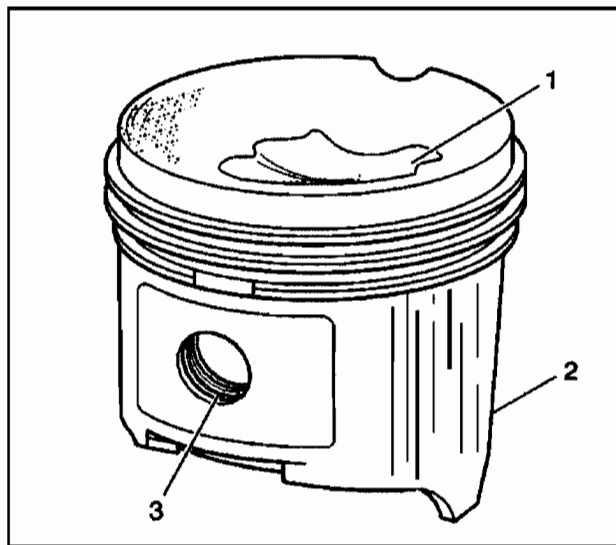
34671

3. Clean the piston ring grooves with a suitable ring groove cleaning tool.

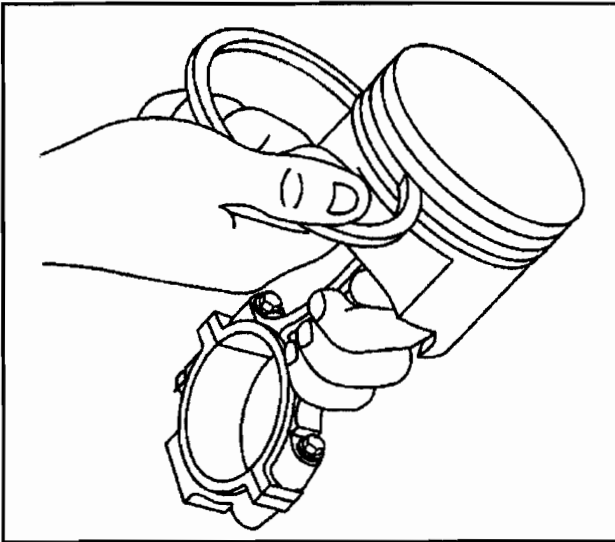


4977

4. Clean the piston oil lubrication holes and slots.
5. Inspect the piston for the following:
 - Eroded areas (1) on the top of the piston
 - Scuffed or damaged skirt (2)
 - Damage to the piston pin bore (3)
 - Cracks in the piston ring lands, the piston skirt, or the piston pin bosses
 - Piston ring grooves for nicks, burrs, or other warpage which may cause the piston ring to bind.
6. Inspect the piston pin for scoring, wear or other damage.



156168



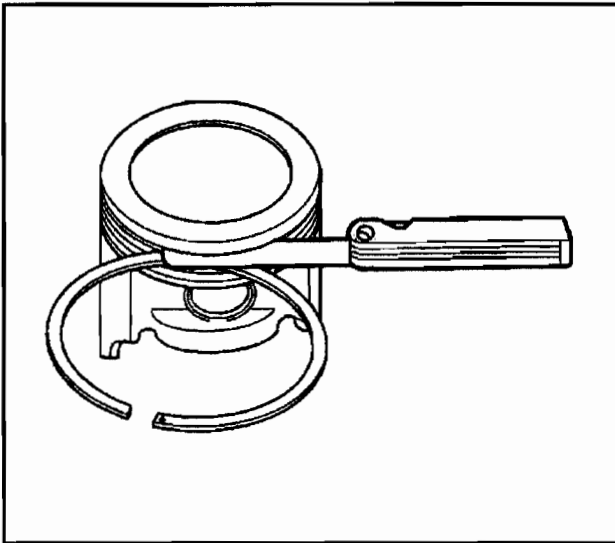
4969

7. Measure the piston ring-to-piston ring groove side clearance.

7.1. Insert the edge of the piston ring into the piston ring groove.

7.2. Roll the piston ring completely around the piston.

- If binding is caused by a distorted piston ring groove, MINOR imperfections may be removed with a fine file.
- If binding is caused by a distorted piston ring, then replace the piston ring.

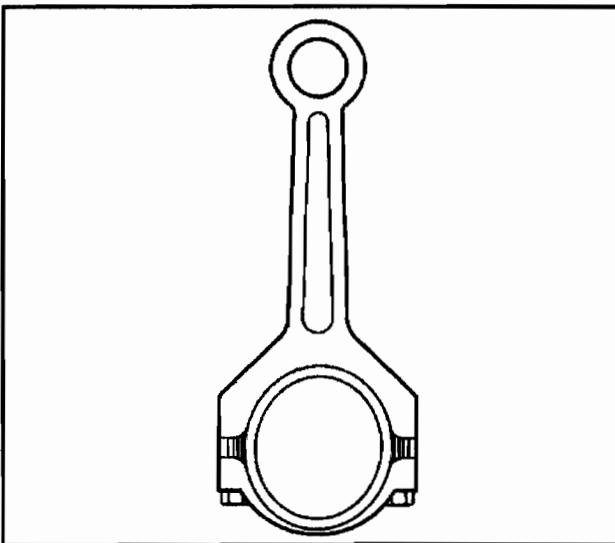


22834

8. Measure the piston ring side clearance with a feeler gage.

- If the piston ring side clearance is too small, try another piston ring set.
- If the proper piston ring-to-piston ring groove clearance cannot be achieved, replace the piston and pin assembly.

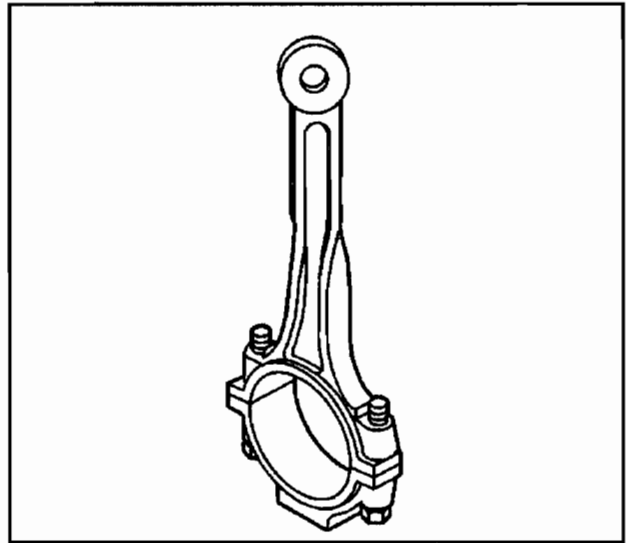
9. To determine the proper piston ring side clearance, refer to *Engine Mechanical Specifications (5.0 L)* or *Engine Mechanical Specifications (5.7 L)*.



156167

10. Inspect the connecting rod for an out-of-round bearing bore. Refer to *Engine Mechanical Specifications (5.0 L)* or *Engine Mechanical Specifications (5.7 L)*.

11. Inspect the connecting rod for twisting.
12. Inspect the connecting rod for damage to the connecting rod bolt threads.



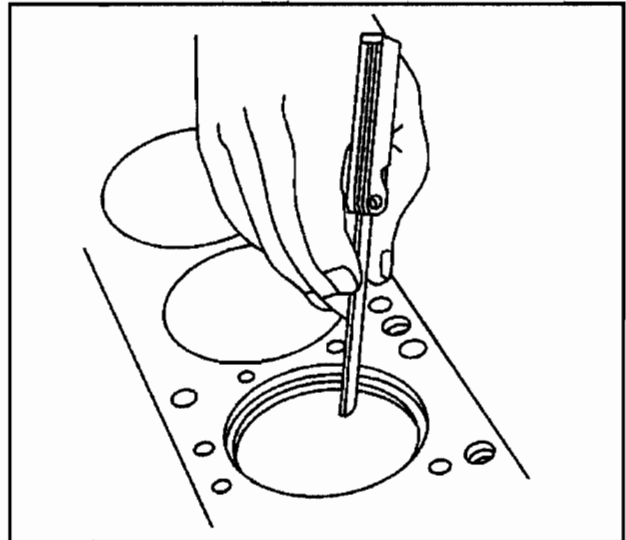
156189

13. Measure the piston compression ring end gap.

Important: Fit each piston compression ring to the cylinder in which it will be used.

- 13.1. Place the piston compression ring into the cylinder bore.
- 13.2. Push the piston compression ring into the cylinder bore to approximately 6.5 mm (0.25 in) above the piston ring travel.
The piston ring must be square to the cylinder wall.
- 13.3. Use a feeler gage in order to measure the piston ring end gap. Refer to *Engine Mechanical Specifications (5.0 L)* or *Engine Mechanical Specifications (5.7 L)*.

Select another size piston ring set if the piston ring end gap exceeds specifications.



4968

Piston and Connecting Rod Assemble

SIE-ID = 195097

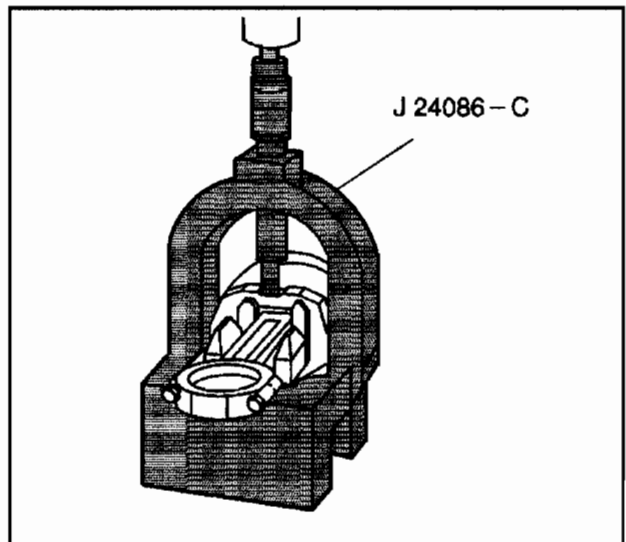
Tools Required

J 24086-C Piston Pin Remover/Installer

Caution: SIO-ID = 71607 **Avoid contact with HOT components. Wear safety glasses and protective gloves to avoid personal injury.**

Notice: SIO-ID = 71608 Applying excessive heat to the connecting rod may damage or distort the rod. Rod temperature SHOULD NOT exceed 315°C (600°F). At this temperature the end of the connecting rod will turn a straw color upon visual inspection.

Notice: SIO-ID = 38775 After the J 24086-C installer hub bottoms on the support assembly, DO NOT exceed 35,000 kPa (5,000 psi) or the tool may be damaged.



4965

Important: When assembling the piston and connecting rod, the mark on the top of the piston must point to the front of the engine block. The left bank connecting rods should have the flange face toward the front of the engine block. The right bank connecting rods should have the flange face toward the rear of the engine block.

The new piston pin has an interference fit into the connecting rod and is full floating in the piston.

1. Install the new piston pin and connecting rod assembly.
 - 1.1. Lubricate the piston pin bores with clean engine oil.
 - 1.2. Use a torch and apply MILD heat to the piston pin end of the connecting rod.
 - 1.3. Use the *J 24086-C* in order to press the new piston pin into the piston and connecting rod assembly.
 - 1.4. Inspect for the proper installation of the piston and piston pin.

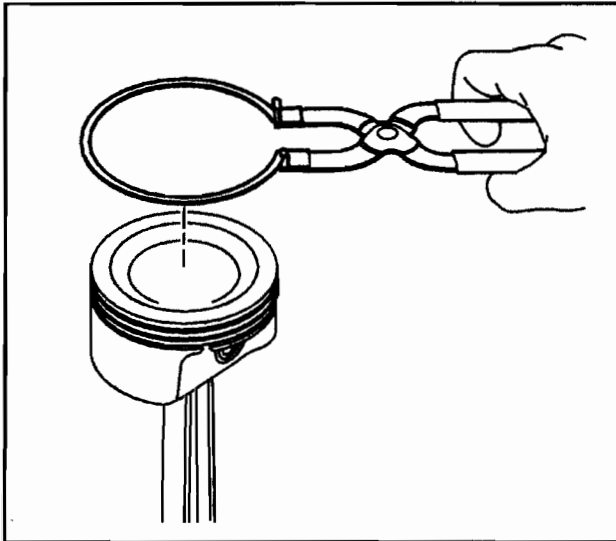
The piston must move freely on the new piston pin with no binding or interference.

Notice: SIO-ID = 16608 Use a piston ring expander to install the piston rings. The rings may be damaged if expanded more than necessary.

2. Install the piston rings onto the piston.
 - 2.1. Install the oil control piston ring spacer.
 - 2.2. Install the lower oil control piston ring.
 - 2.3. Install the upper oil control piston ring.
 - 2.4. Install the lower compression piston ring.

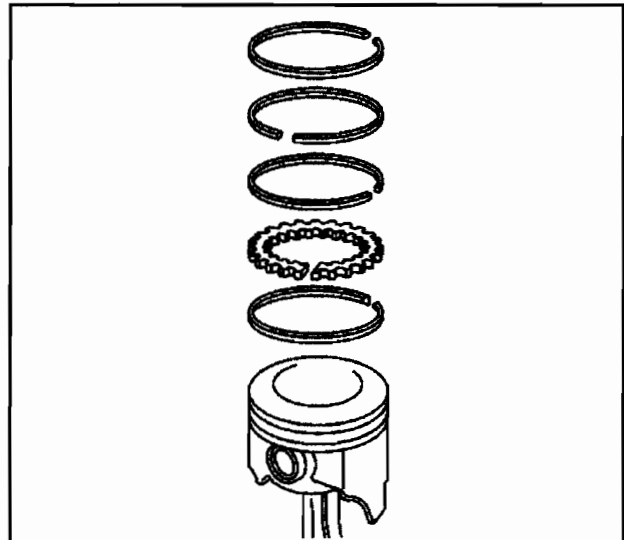
The mark on the side of the piston ring should face the top of the piston.
 - 2.5. Install the upper compression piston ring.

The mark on the side of the piston ring should face the top of the piston.



490763

3. Space the compression piston ring end gaps 120 degrees apart.
4. Space the oil control piston ring end gaps a minimum of 90 degrees apart.



4967

Crankshaft and Bearings Cleaning and Inspection

SIE-ID = 69074

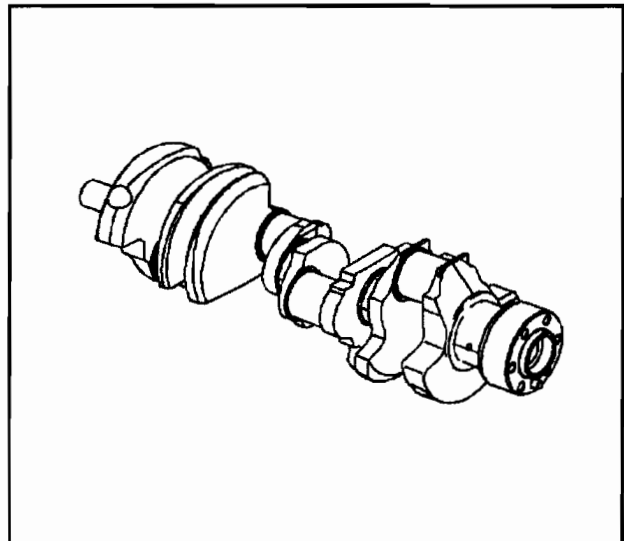
Tools Required

- J 7872 Magnetic Base Dial Indicator
- J 36660-A Torque Angle Meter
- J 43690 Rod Bearing Clearance Checking Tool

Caution: Refer to *Safety Glasses Caution in Cautions and Notices.*

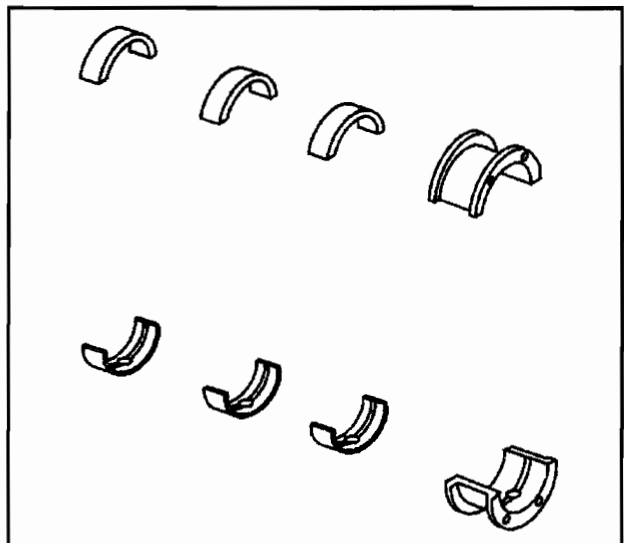
Important: Use care when handling the crankshaft. Avoid damage to the crankshaft bearing surfaces.

1. Clean the crankshaft in cleaning solvent. Remove all sludge or restrictions from the oil passages.
2. Dry the crankshaft with compressed air.

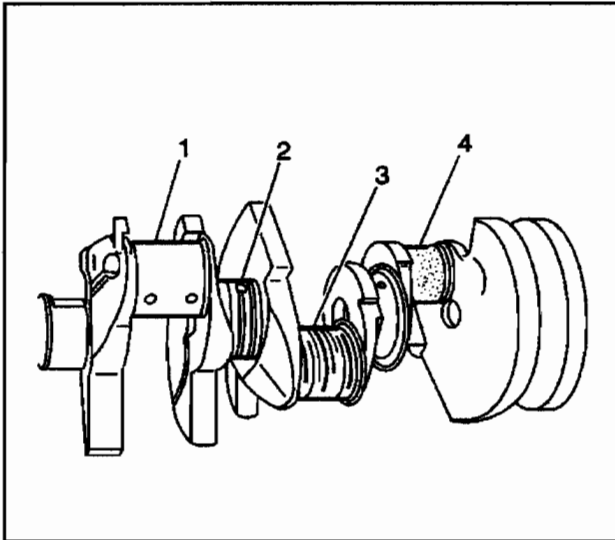


59918

3. Clean the crankshaft bearings in cleaning solvent. Wipe the crankshaft bearings clean with a soft cloth. Do not scratch the crankshaft bearing surfaces.
4. Dry the crankshaft and crankshaft bearings with compressed air.

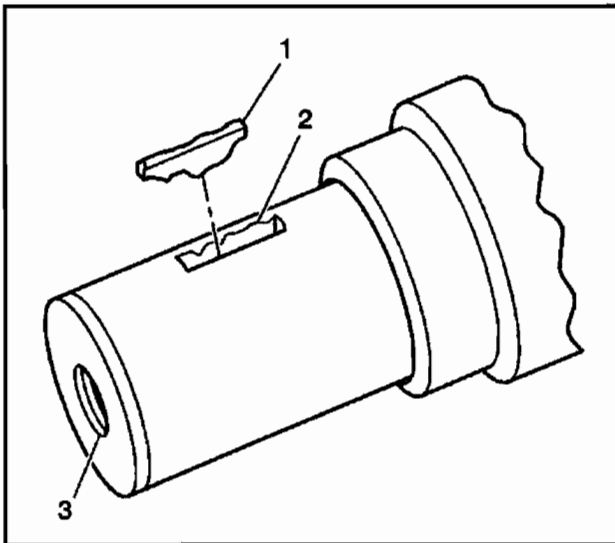


334386



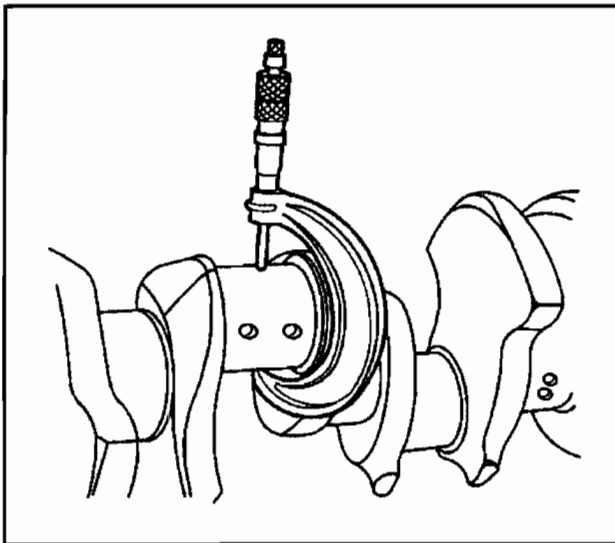
156170

5. Inspect the crankshaft for the following:
- Crankshaft journals (1) should be smooth with no evidence of scoring or damage.
 - Deep grooves (2)
 - Scratches or uneven wear (3)
 - Pitted surfaces (4)
 - Wear or damage to the thrust journal surfaces
 - Scoring or damage to the rear seal surface
 - Restrictions to the oil passages
 - Damage to the threaded bolt holes



188090

6. Inspect the crankshaft balancer woodruff keys (1), the keyway (2), and the threaded hole (3) for damage.

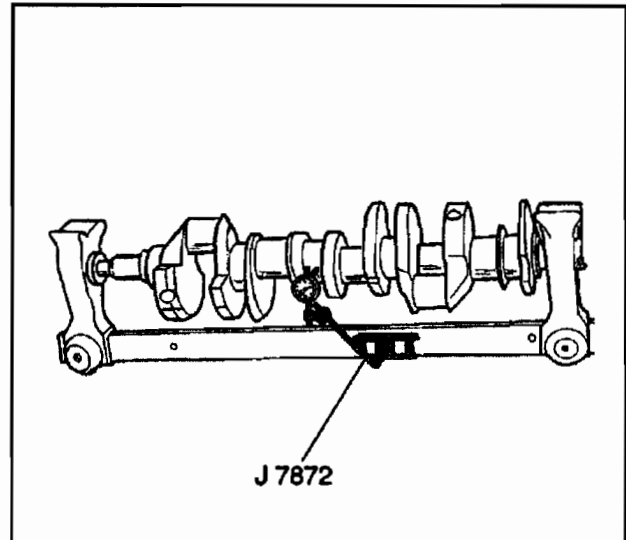


188015

7. Measure the crankpins for out-of-round and taper. Refer to *Engine Mechanical Specifications (5.0 L)* or *Engine Mechanical Specifications (5.7 L)*.

8. Using wooden V-blocks, support the crankshaft on the front and rear journals.
9. Use the J 7872 in order to measure crankshaft journal runout.

Refer to *Engine Mechanical Specifications (5.0 L)* or *Engine Mechanical Specifications (5.7 L)*.



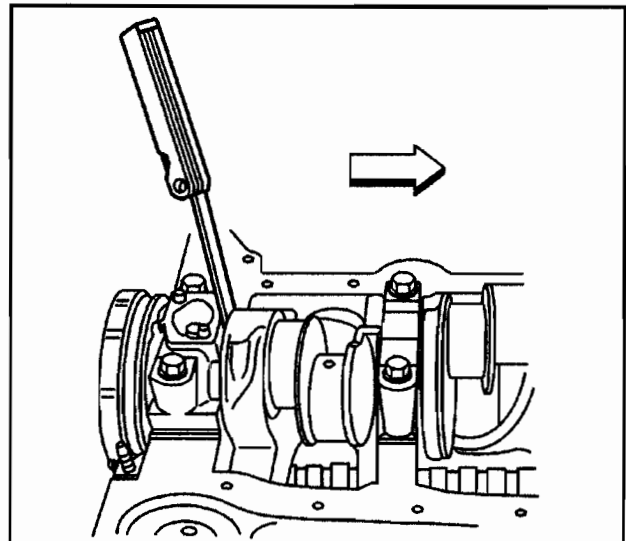
35210

10. Measure the crankshaft end play.

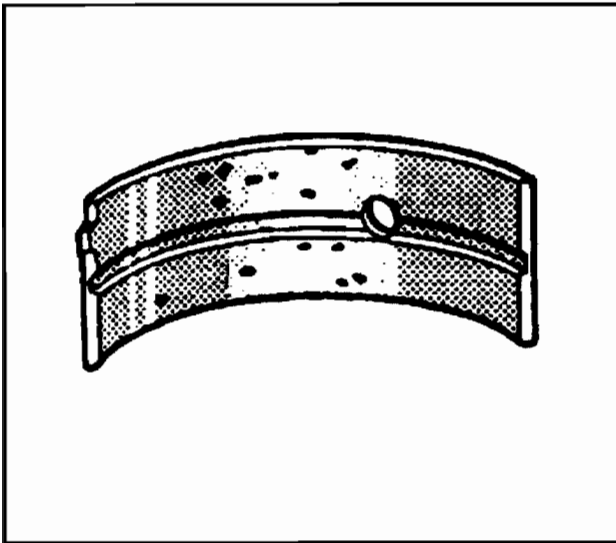
Important: In order to properly measure the crankshaft end play, the crankshaft, the crankshaft bearings, the crankshaft bearing caps, and the fasteners must be installed into the engine block, and the bolts and studs tightened finger tight.

- 10.1. Firmly thrust the end of the crankshaft, first rearward then forward. This will line up the rear crankshaft bearing and the crankshaft thrust surfaces. Tighten the cap bolts and studs. Refer to *Engine Mechanical Specifications (5.0 L)* or *Engine Mechanical Specifications (5.7 L)*.
- 10.2. With the crankshaft pushed forward, insert a feeler gage between the crankshaft and the crankshaft bearing surface, then measure the clearance. Refer to *Engine Mechanical Specifications (5.0 L)* or *Engine Mechanical Specifications (5.7 L)*.
- 10.3. Turn the crankshaft to check for binding. If the crankshaft does not turn freely, loosen the crankshaft bearing bolts and studs, one crankshaft bearing cap at a time, until the tight crankshaft bearing is located.

Burrs on the crankshaft bearing cap or engine block, foreign matter between the crankshaft bearing and the crankshaft bearing cap or the engine block, or a faulty crankshaft bearing could cause a lack of clearance between the crankshaft and crankshaft bearing.

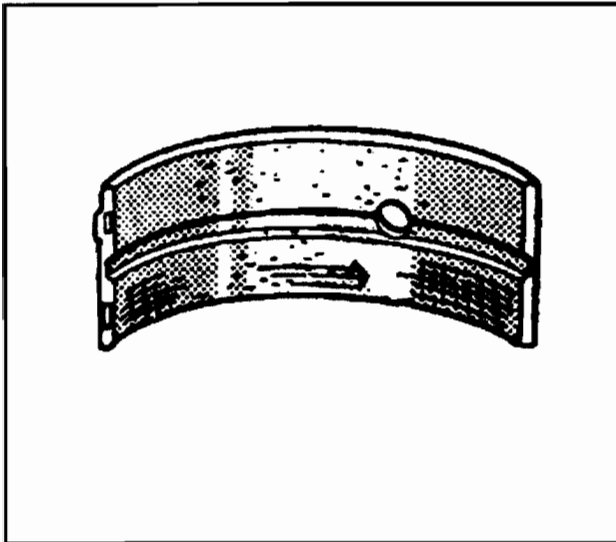


188467



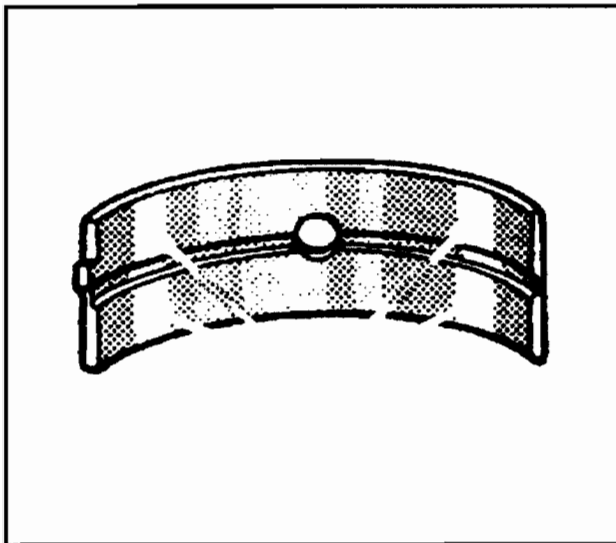
52051

11. Inspect the crankshaft bearings for craters or pockets. Flattened sections on the crankshaft bearing halves also indicate fatigue.



52053

12. Inspect the crankshaft bearings for excessive scoring or discoloration.
13. Inspect the crankshaft bearings for dirt or debris imbedded into the crankshaft bearing material.



52056

14. Inspect the crankshaft bearings for improper seating indicated by bright, polished sections of the crankshaft bearings.
- If the lower half of the crankshaft bearing is worn or damaged, both the upper and lower halves of the crankshaft bearing should be replaced.
 - Generally, if the lower half of the crankshaft bearing is suitable for use, the upper half of the crankshaft bearing should also be suitable for use.

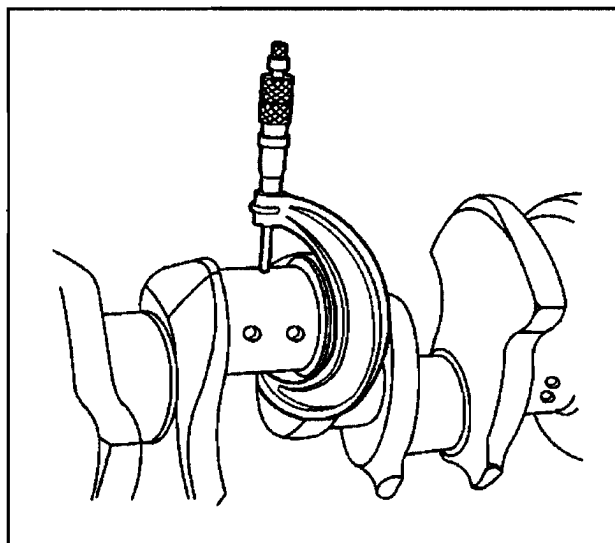
Measuring Crankshaft Bearing Clearances

Notice: SIO-ID = 5016 Do not shim, scrape, or file bearing inserts. Do not touch the bearing surface of the insert with bare fingers. Skin oil and acids will etch the bearing surface.

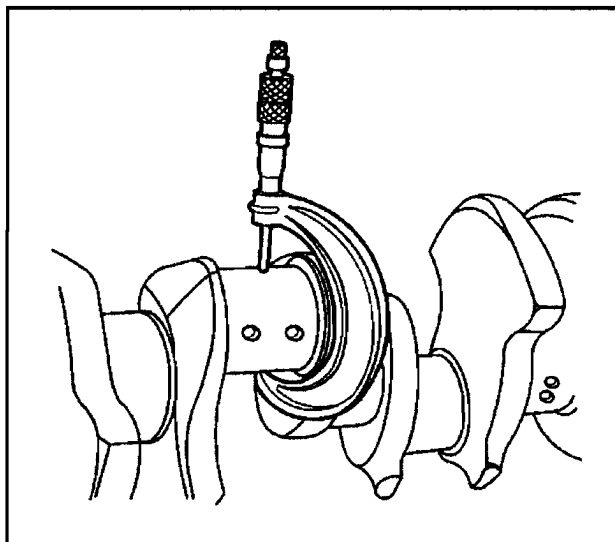
- The crankshaft bearings are precision insert type and do not use shims for adjustment. If the clearances are excessive, then new upper and lower crankshaft bearings will be required. The service crankshaft bearings are available in the standard size and an undersize.
- The selective fitting of the crankshaft bearings are necessary in production in order to obtain close tolerances. For this reason, in one journal bore you may use one-half of a standard crankshaft bearing with one-half of an undersize crankshaft bearing.
- In order to determine the correct replacement bearing size, the bearing clearance must be measured accurately. When checking main bearing clearances, either the micrometer or plastic gage method may be used. The micrometer method gives more reliable results and is preferred. When checking connecting rod bearing clearances, the plastic gage method will result in unreliable measurements. The use of *J 43690* is preferred.
- If the crankshaft bearing clearance is within specifications, the crankshaft bearing is satisfactory. If the clearance is not within specifications, replace the crankshaft bearing. Always replace both the upper and lower crankshaft bearings as a unit.
- A standard, or undersize crankshaft bearing combination, may result in the proper clearance. If the proper crankshaft bearing clearance cannot be achieved using the standard or the undersize crankshaft bearings, it may be necessary to repair or replace the crankshaft.

Measuring Crankshaft Bearing Clearances – Micrometer Method

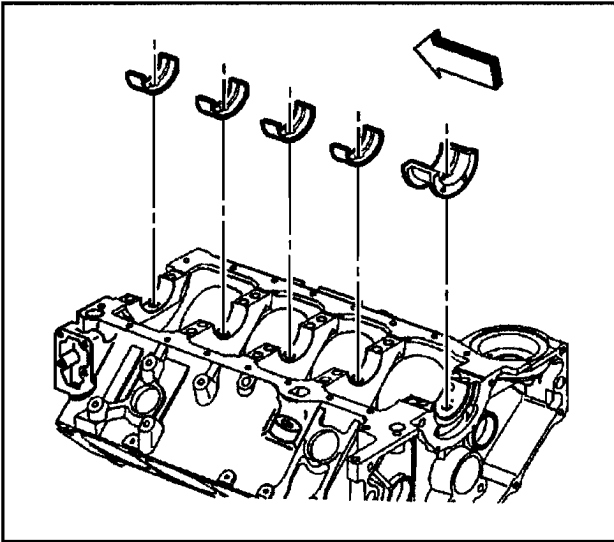
1. Measure the crankshaft journal diameter with a micrometer in several places, approximately 90 degrees apart. Average the measurements.
2. Determine the taper and out-of-round of the journal. Refer to *Engine Mechanical Specifications (5.0 L)* or *Engine Mechanical Specifications (5.7 L)*.



188015



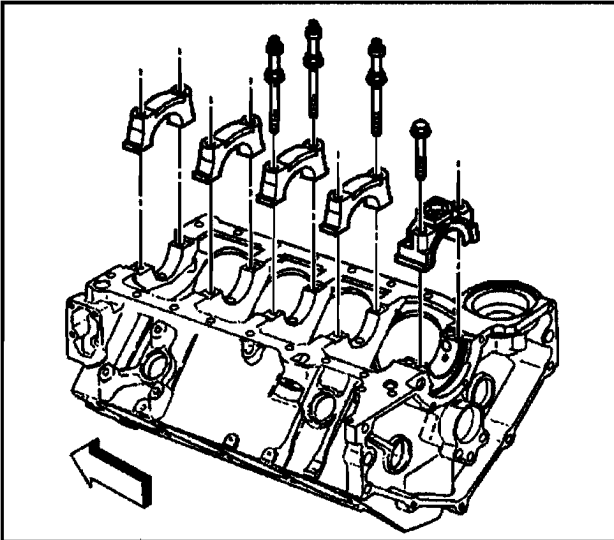
188015



317292

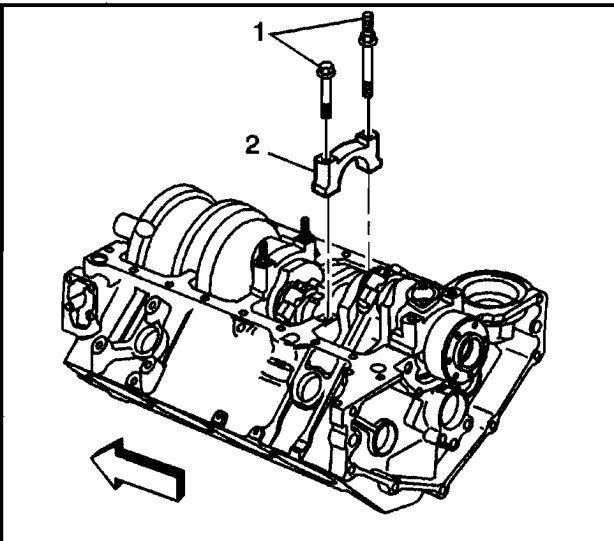
3. Install the bearings into the engine block.

Notice: Refer to *Fastener Notice* in Cautions and Notices.



353070

4. Install the bearing cap bolts and tighten to specifications. Refer to *Fastener Tightening Specifications*.
5. Measure the bearing inside diameter (ID) at the top and bottom.
6. In order to determine the bearing clearance, subtract the average journal diameter from the bearing inside diameter.
7. Compare the readings to specifications. Refer to *Engine Mechanical Specifications (5.0 L)* or *Engine Mechanical Specifications (5.7 L)*.
8. Replace bearing halves as required to obtain the proper bearing clearances.



627138

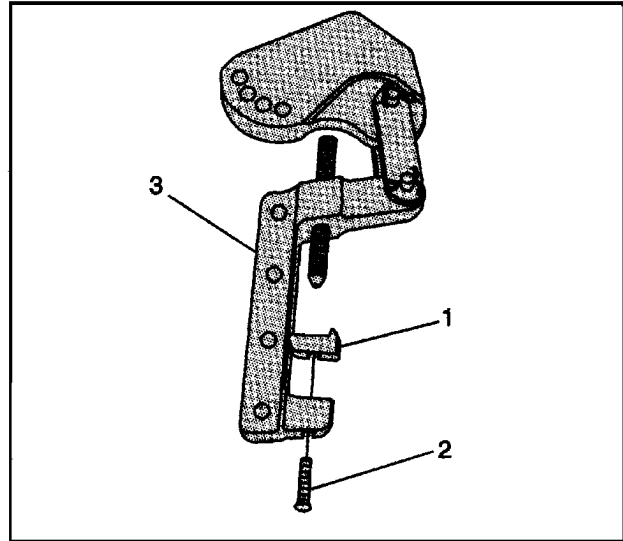
Measuring Connecting Rod Bearing Clearances – J 43690 Method

1. Remove the oil pan and other necessary components to gain access to the connecting rods. Remove the oil pump, screen, and deflector, when applicable.
2. Rotate the crankshaft until the crankshaft journal/connecting rod to be measured is in the 10 o'clock position.

Important: The crankshaft must be secure, with no movement or rotation, in order to obtain an accurate reading. Remove an intermediate bearing cap, as required, in order to secure the crankshaft and allow measurement of connecting rod bearing clearances.

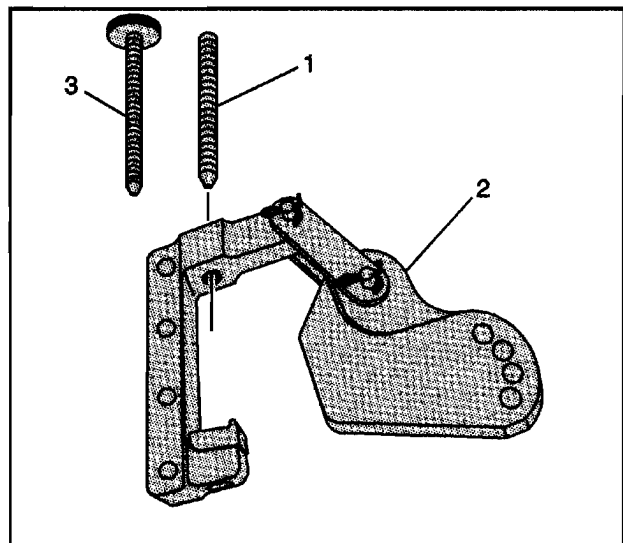
3. Remove the bearing cap bolts (1), cap (2) and bearing half.

4. Insert a piece of paper card stock onto the crankshaft journal. Install the bearing half, bearing cap, and bolts. Refer to *Fastener Tightening Specifications*.
5. Install the foot (1) and bolt (2) to the pivot arm assembly (3).
6. Tighten the bolt until snug.

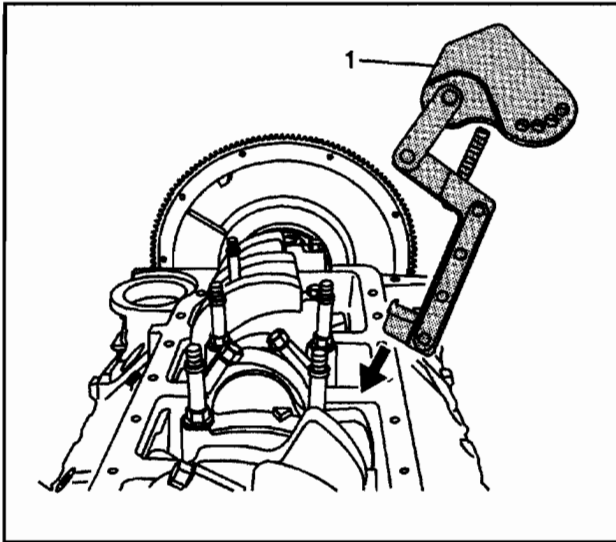


627102

7. Install the screw (1 or 3) to the pivot arm assembly (2).

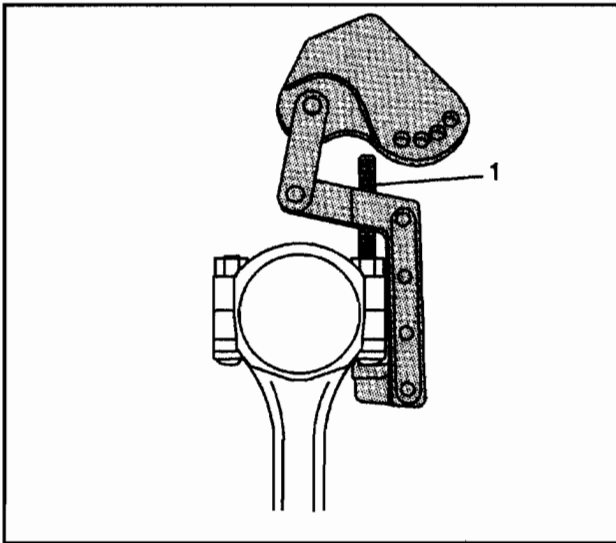


627106



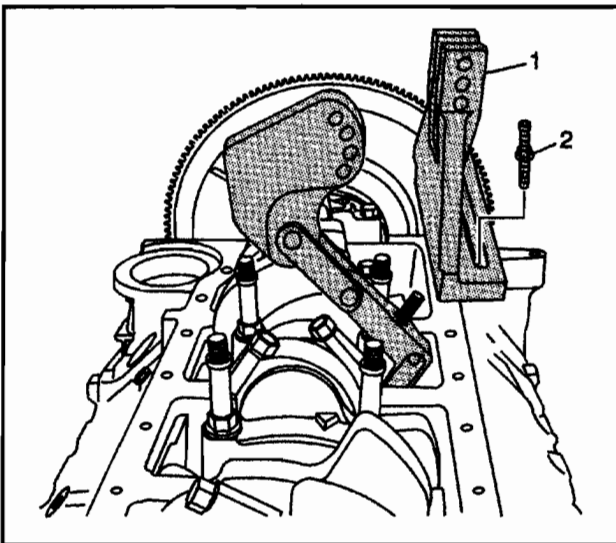
627108

8. Install the pivot arm assembly (1) onto the connecting rod.



627107

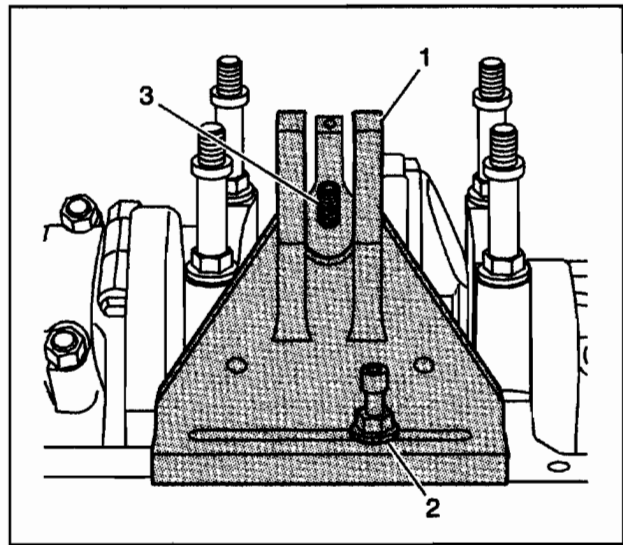
9. Position the foot of the pivot arm assembly over the large end of the connecting rod bolt.
10. Position the screw (1) onto the small end of the connecting rod bolt and tighten securely.



627109

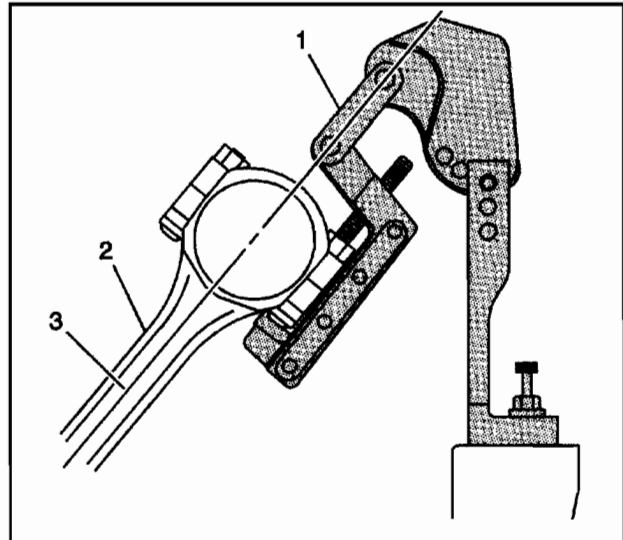
11. Install the base (1) and bolt (2) to the oil pan rail.

- 12. Align the center of the base (1) with the screw (3) of the pivot arm assembly.
- 13. Tighten the bolt (2) until snug.



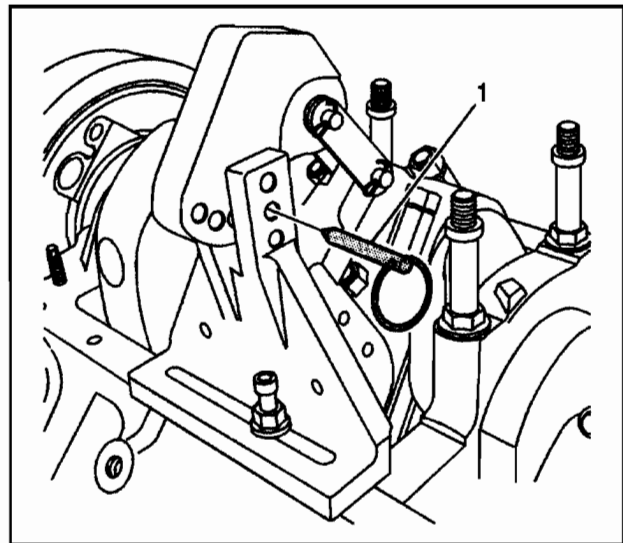
627115

- 14. Align the link (1) of the pivot arm assembly on a plane (3) equal to that of the connecting rod beam (2).

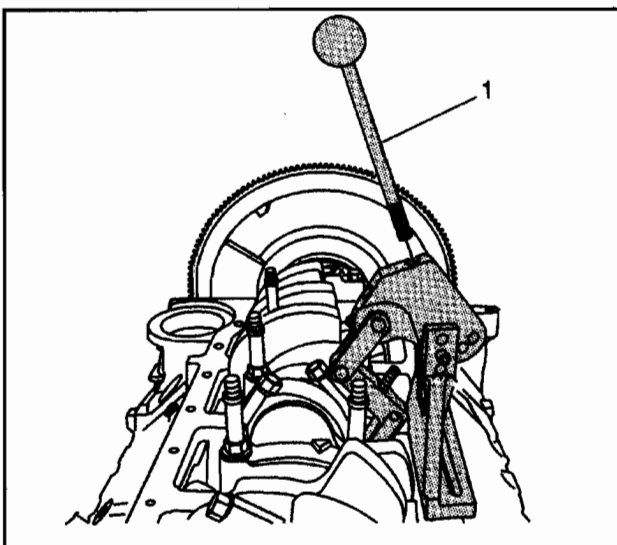


627113

- 15. With the link of the pivot arm assembly aligned to the beam of the connecting rod, position the pivot arm to the base and insert the pin (1).

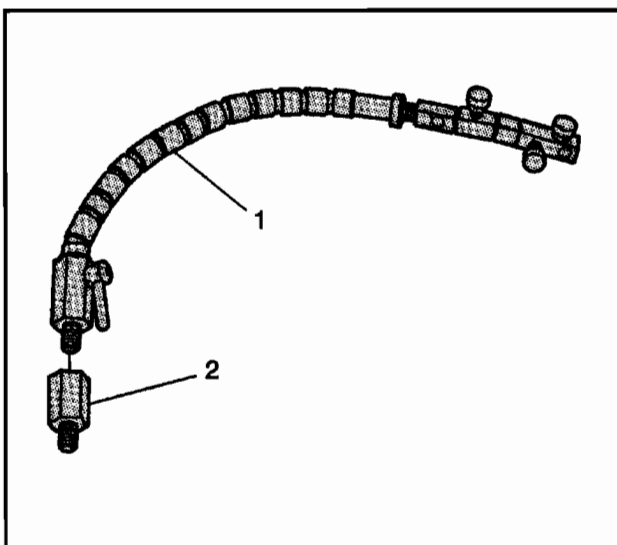


627111



627116

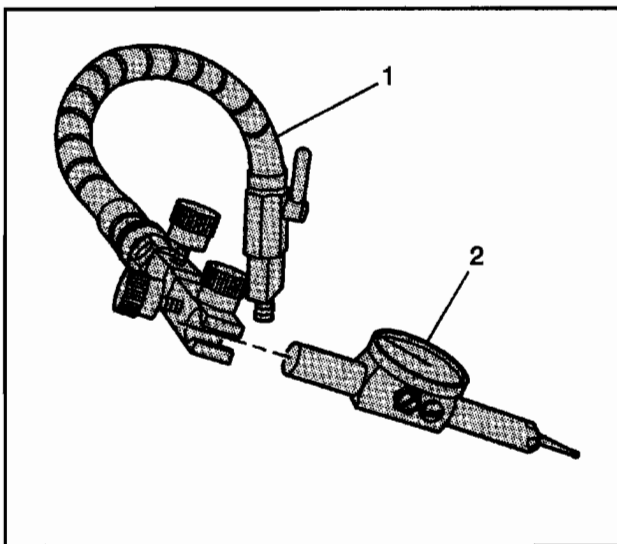
16. Insert the handle (1) to the pivot arm assembly.



627118

17. Select the adapter (2), as required, and install to the swivel base (1).

18. Tighten until snug.



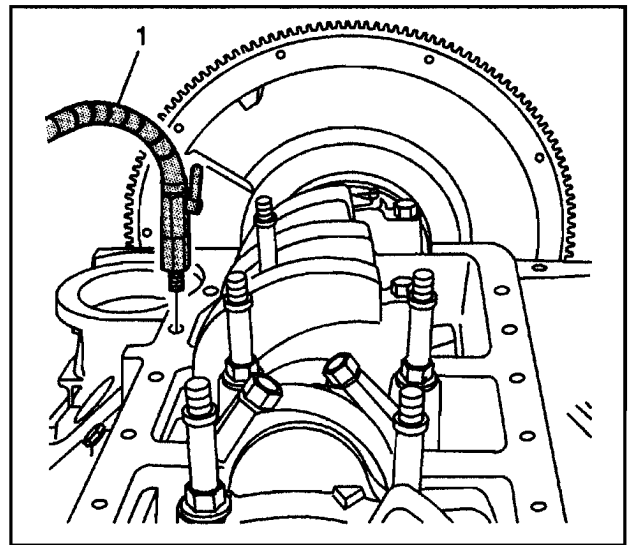
627122

Important: The clamp of the swivel base and the shaft of the indicator should be free of oil or other debris. A loose or improperly clamped indicator may indicate incorrect readings.

19. Install the indicator (2) to the swivel base (1).

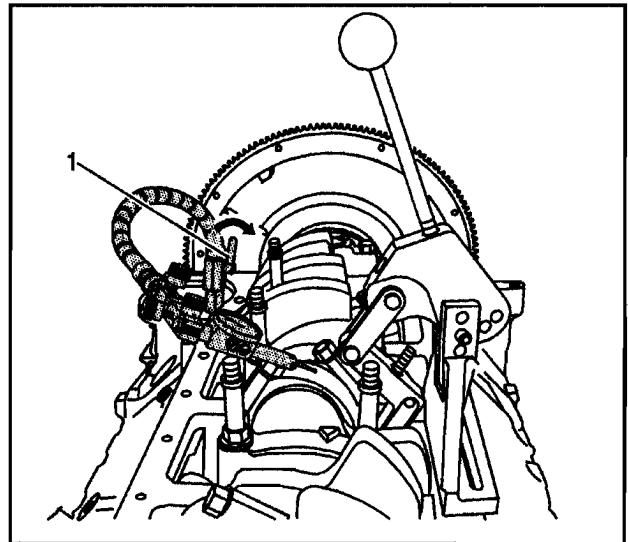
20. Tighten the clamp of the base until snug.

21. Install the swivel base (1) to the oil pan rail of the engine block.
22. Tighten until snug.



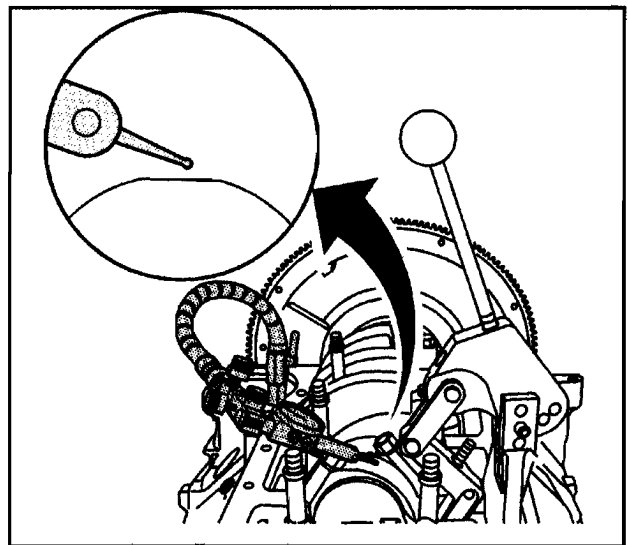
627124

23. Adjust the swivel base as required, and position the indicator tip slightly above the connecting rod cap. Lock the swivel base in position by rotating the locking lever (1). Do not allow the tip of the indicator to contact the connecting rod at this time.

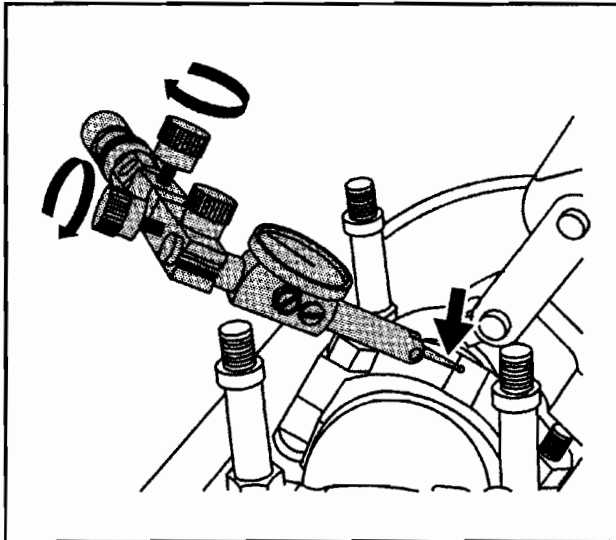


627126

24. The tip of the indicator should be positioned above, and NOT in contact with the cap end of the connecting rod.

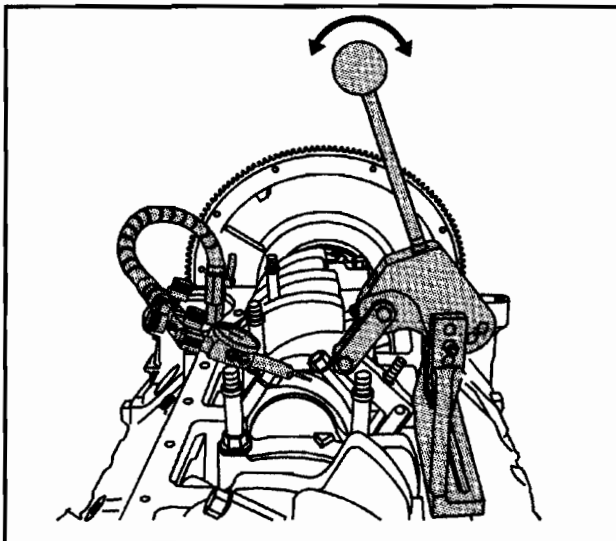


627129



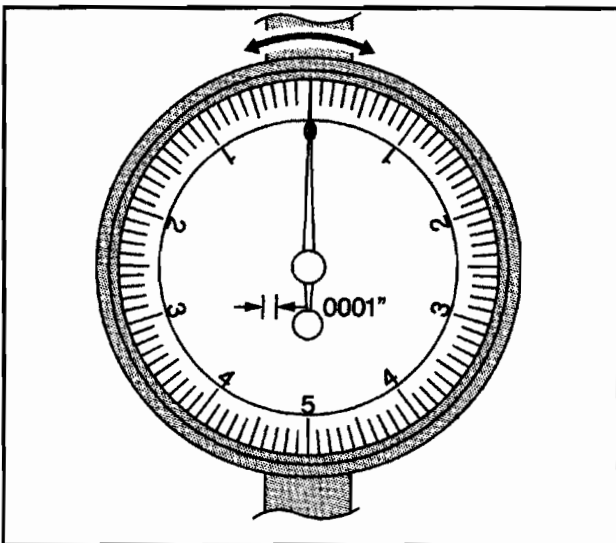
627132

25. Rotate the fine adjustment knobs, on the dial indicator end of the swivel base, to position the tip of the indicator in contact with the connecting rod.



627141

26. Lightly actuate the handle of the pivot arm assembly, multiple times in both directions, to ensure the oil film is removed from the journal.



627135

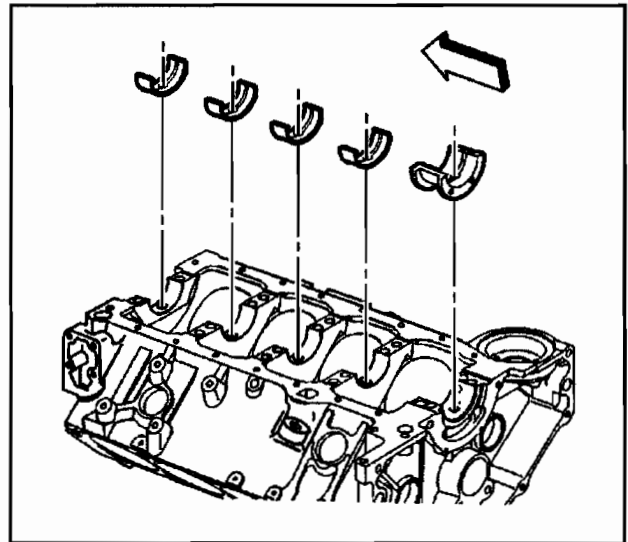
27. Load the handle in the forward position and zero the dial indicator. Load the handle multiple times in both directions and record the reading.

Important: During this procedure, card stock may enter the crankshaft journal oil galleries. Remove all card stock from the bearing journal and oil galleries prior to reassembly.

28. Remove the bearing cap bolts, cap, and paper stock.
29. Replace bearing halves, as required, to obtain the proper bearing clearances.
30. Install the bearings, cap, and bolts. Refer to *Fastener Tightening Specifications*.

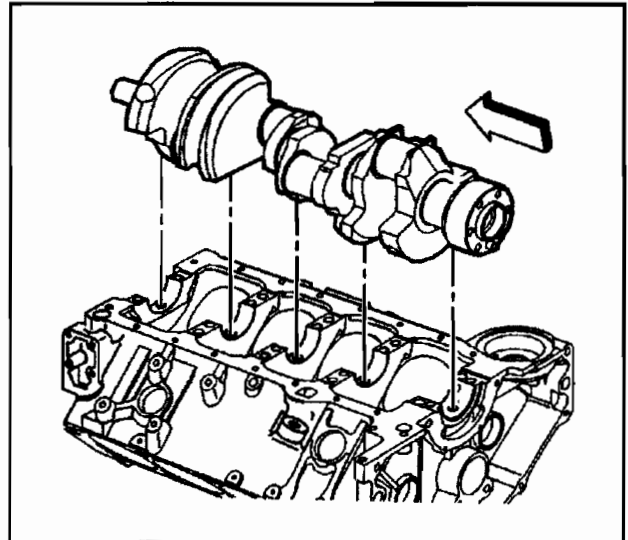
Measuring Crankshaft Bearing Clearances – Plastic Gage Method

1. Install the crankshaft bearings into the engine block.



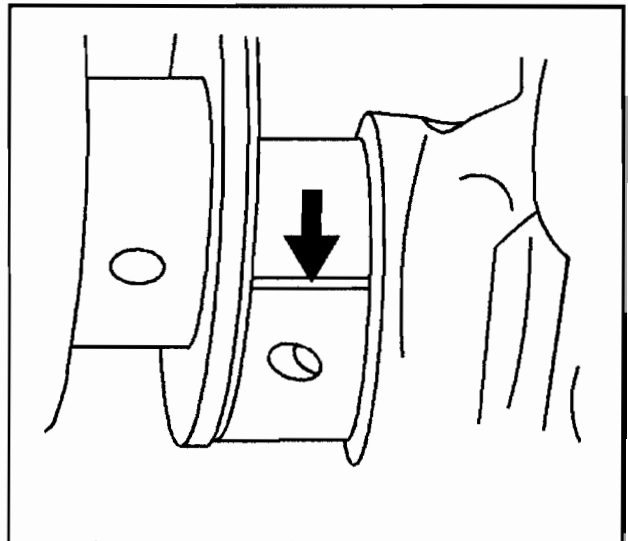
317292

2. Install the crankshaft.

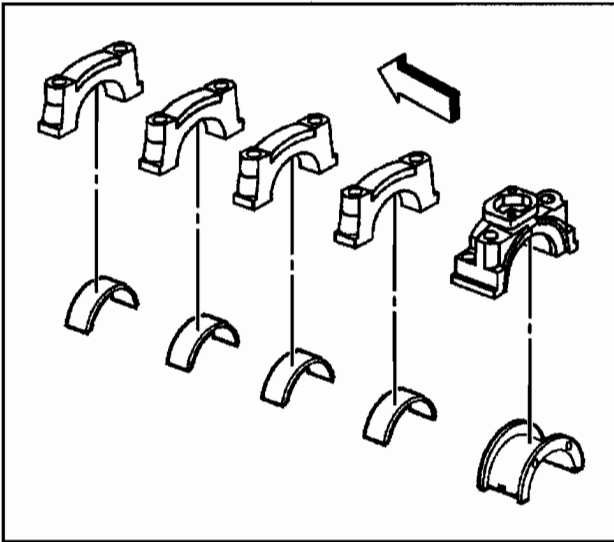


317351

3. Install the gaging plastic the full width of the journal.

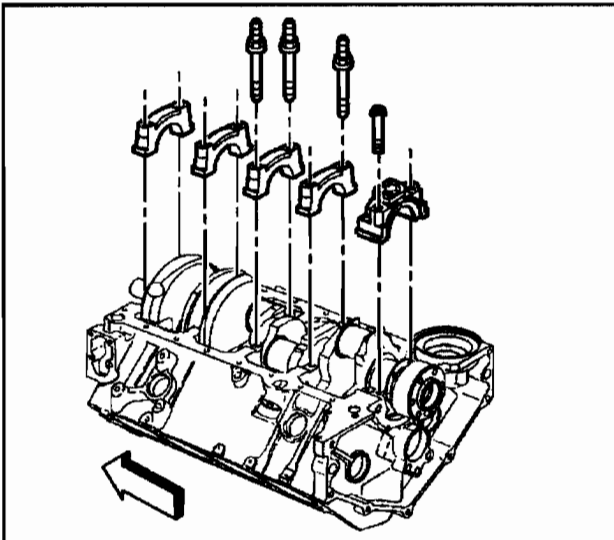


500655



317295

4. Install the crankshaft bearings into the crankshaft bearing caps.

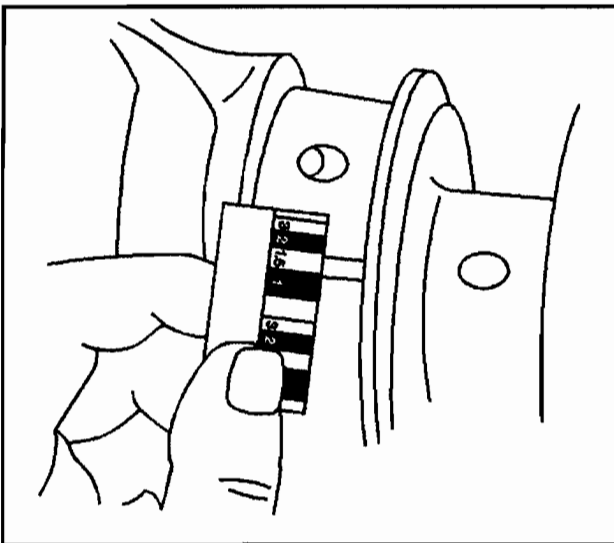


317266

5. Install the crankshaft bearing caps in the original positions, and the arrow on the crankshaft bearing caps in the direction of the front of the engine block.

Notice: Refer to *Fastener Notice* in Cautions and Notices.

6. Install the crankshaft bearing cap bolts and the crankshaft bearing cap studs. Refer to *Fastener Tightening Specifications*.
7. Remove the crankshaft bearing cap bolts and studs.
8. Remove the crankshaft bearing caps. The gaging plastic may adhere to either the crankshaft bearing journal or the crankshaft bearing surface.



500656

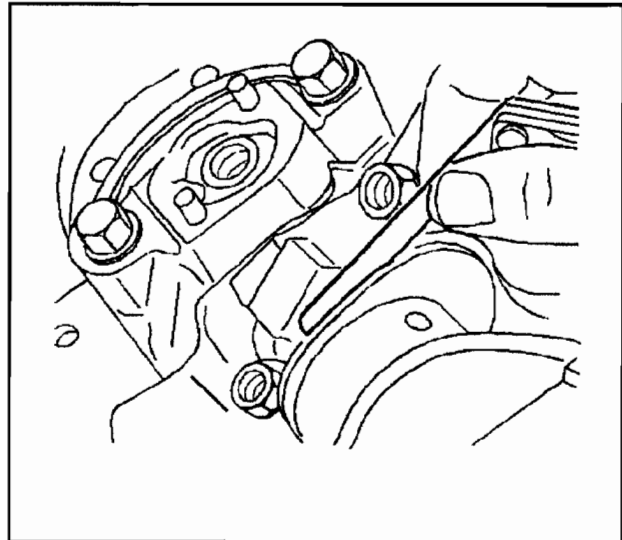
9. Without removing the gaging plastic, measure the compressed width at the widest point, using the graduated scale on the edge of the gaging plastic envelope.

If the flattened gaging plastic tapers toward the middle or the ends, there may be a difference in clearance indicating taper, low spot or other irregularity of the crankshaft bearing or the crankshaft bearing journal.

10. Remove the flattened gaging plastic.
11. Measure the remaining crankshaft bearing journals.

Measuring Connecting Rod Bearing Side Clearance

1. Insert a feeler gage between the connecting rod caps and measure the connecting rod side clearance. Refer to *Engine Mechanical Specifications (5.0 L)* or *Engine Mechanical Specifications (5.7 L)*.
2. The connecting rod side clearances may also be measured with a dial indicator set.



5163

Crankshaft Balancer Cleaning and Inspection

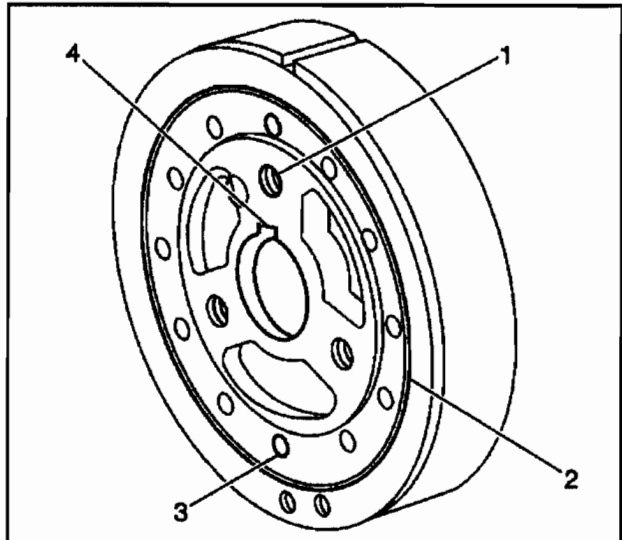
SIE-ID = 194518

Caution: Refer to *Safety Glasses Caution in Cautions and Notices*.

1. Clean the crankshaft balancer in cleaning solvent.
2. Dry the crankshaft balancer with compressed air.
3. Inspect the crankshaft balancer for the following:
 - Worn or damaged bolt hole threads (1)
 - Worn, chunking, or deteriorated rubber (2) between the hub and outer ring
 - Loose or improperly installed balance weights (3)

A properly installed balance weight should be installed until flush or below flush with the face of the crankshaft balancer.

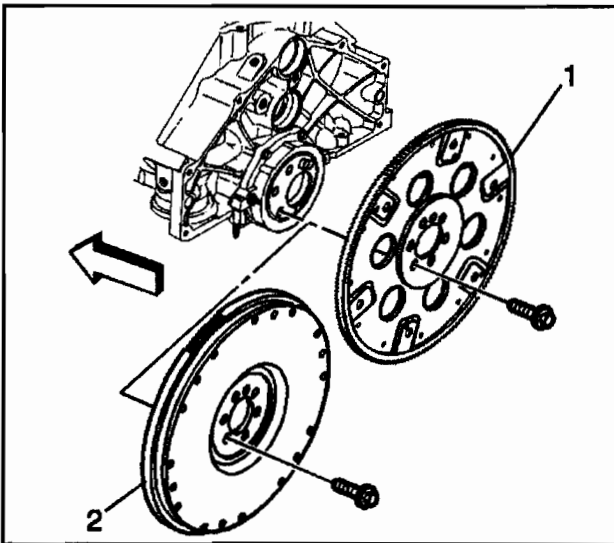
 - Worn or damaged keyway (4)



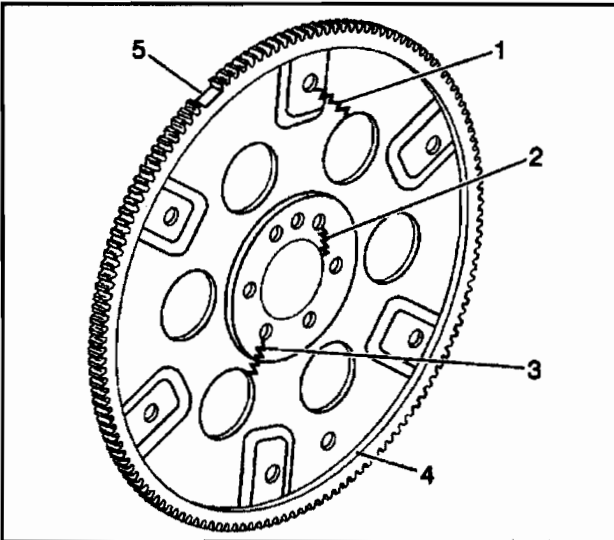
334038

Important: A crankshaft front oil sealing surface with excessive scoring, grooves, rust, or other damage must be replaced.

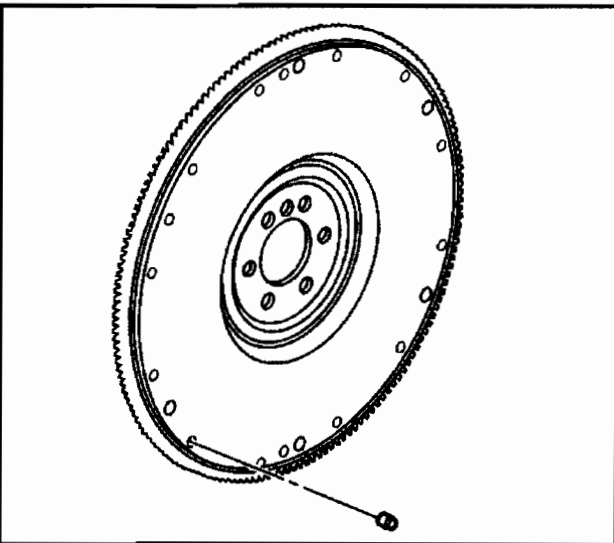
- Worn, grooved, or damaged crankshaft front oil sealing surface
- Minor imperfections on the crankshaft balancer crankshaft front oil seal surface may be removed with a polishing compound or fine grade emery cloth.



188129



381965



64126

Engine Flywheel Cleaning and Inspection

SIE-ID = 195065

Caution: Refer to Safety Glasses Caution in Cautions and Notices.

1. Clean the engine flywheel (1 or 2) in cleaning solvent.
2. Dry the engine flywheel with compressed air.

3. Inspect the engine flywheel, automatic transmission, if equipped, for the following:

- Stress cracks around the engine flywheel-to-torque converter bolt hole locations (1)
- Missing balance weights
- Stress cracks around the engine flywheel-to-crankshaft bolt hole locations (2 or 3)

Important: Do not attempt to repair the welded areas that retain the ring gear to the engine flywheel plate. Always install a NEW engine flywheel.

- Welded areas that retain the ring gear onto the engine flywheel for cracking (4)
- Damaged ring gear teeth (5)

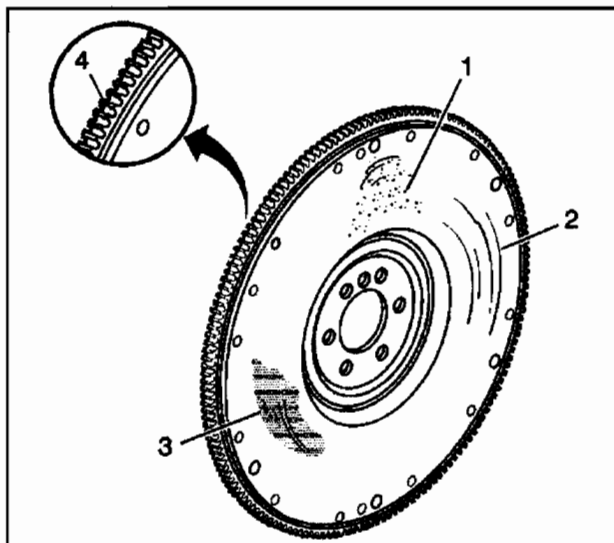
4. Inspect the engine flywheel for loose or improperly installed flywheel weights, if applicable.

A properly installed flywheel weight should be installed until flush or below flush with the face of the engine flywheel.

5. Inspect the engine flywheel, manual transmission, if equipped, for the following:

- Pitted friction surface (1)
- Scoring or grooves (2)
- Rust or other surface damage (3)
- Damaged ring gear teeth (4)
- Loose or improperly positioned ring gear

The ring gear has an interference fit onto the engine flywheel and the ring gear should be positioned completely flat against the flange of the engine flywheel.



188086

Camshaft and Bearings Cleaning and Inspection

SIE-ID = 32312

Tools Required

J 7872 Magnetic Base Dial Indicator

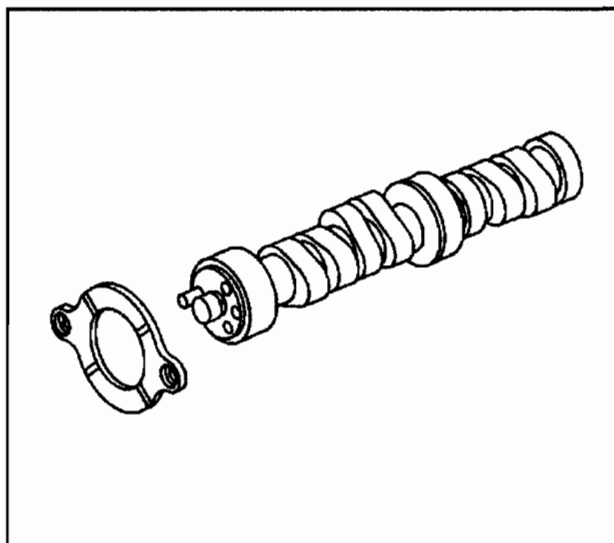
Caution: Refer to Safety Glasses Caution in Cautions and Notices.

1. Clean the engine camshaft in cleaning solvent.
2. Dry the engine camshaft with compressed air.
3. Inspect the camshaft retainer plate for damage. If the camshaft retainer plate is damaged, replace as necessary.
4. Inspect the camshaft bearings for correct fit into the engine block camshaft bearing bores.

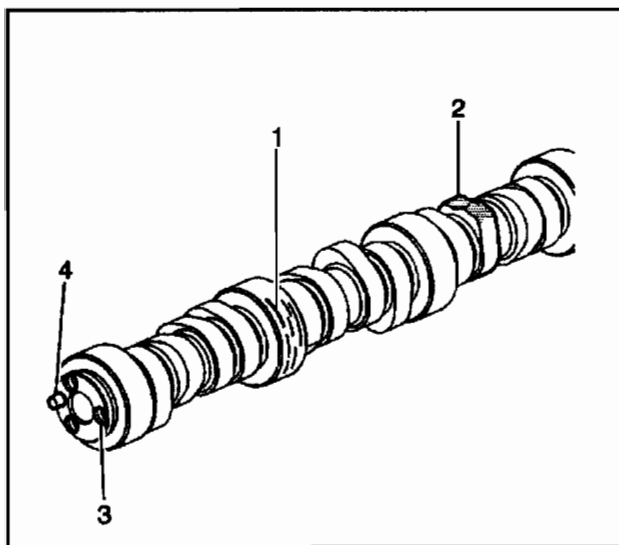
The camshaft bearings have an interference fit to the engine block camshaft bearing bores and must not be loose in the engine block camshaft bearing bores.

Important: If any camshaft bearing is excessively worn or scored, replace all the camshaft bearings.

5. Inspect the camshaft bearings for excessive wear or scoring.

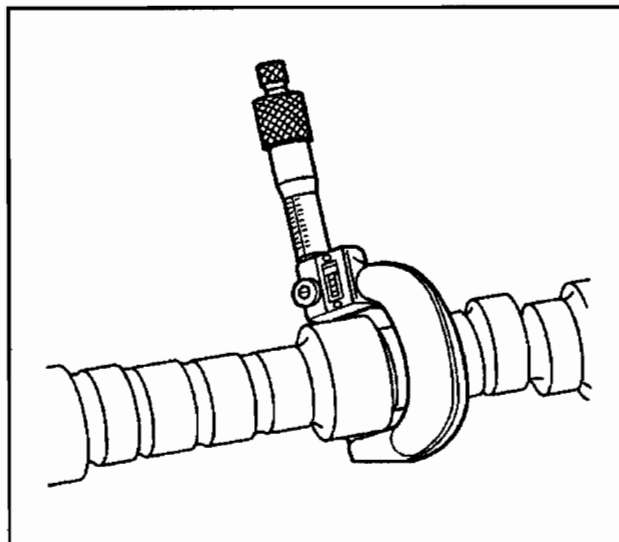


334499



188095

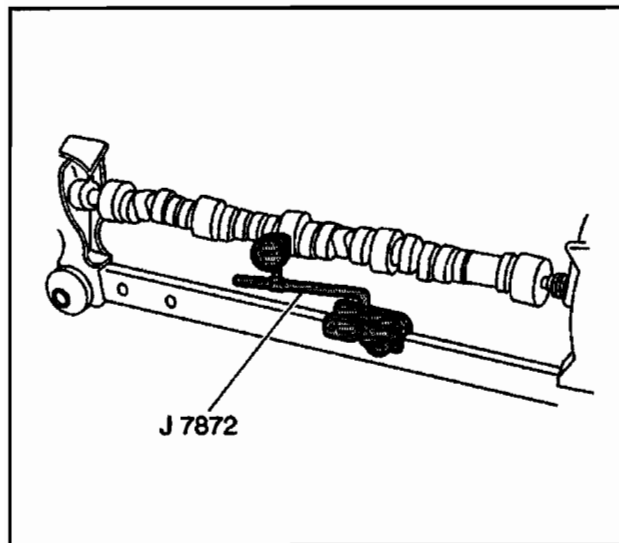
6. Inspect the engine camshaft for the following:
- Worn, scored, or damaged bearing journals (1)
 - Worn engine camshaft lobes (2)
 - Damaged bolt hole threads (3)
 - Damaged camshaft sprocket locator pin (4)



188014

7. Measure the engine camshaft journals with a micrometer.

If the camshaft journals are more than 0.025 mm (0.0010 in) out-of-round, then replace the engine camshaft.



188012

8. Measure for a bent engine camshaft or excessive engine camshaft runout using the *J 7872*.

- 8.1. Mount the engine camshaft in a suitable stand between centers.
- 8.2. Use the *J 7872* in order to check the intermediate engine camshaft journals.
If the runout exceeds 0.065 mm (0.0026 in), the engine camshaft is bent and must be replaced.

9. Measure the engine camshaft lobe lift using the *J 7872*.
- 9.1. Place the engine camshaft on the V-blocks.
 - 9.2. Use the *J 7872* in order to measure the engine camshaft lobe lift.
10. Replace the engine camshaft if the engine camshaft lobe lift is not within specifications.

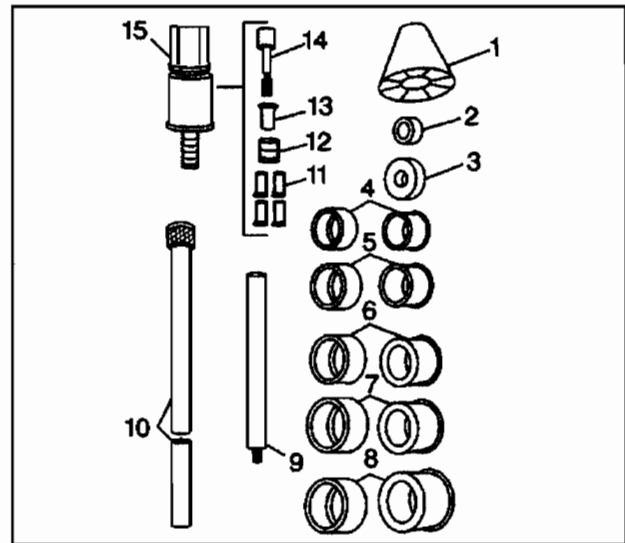
Camshaft Bearing Removal

SIE-ID = 195130

Tools Required

J 33049 Camshaft Bearing Service Kit

1. Select the cone (1), the handle (10), the expanding driver (4–8), the washer (2 or 3), and the expander assembly (15) from the J 33049.
2. Assemble the J 33049.



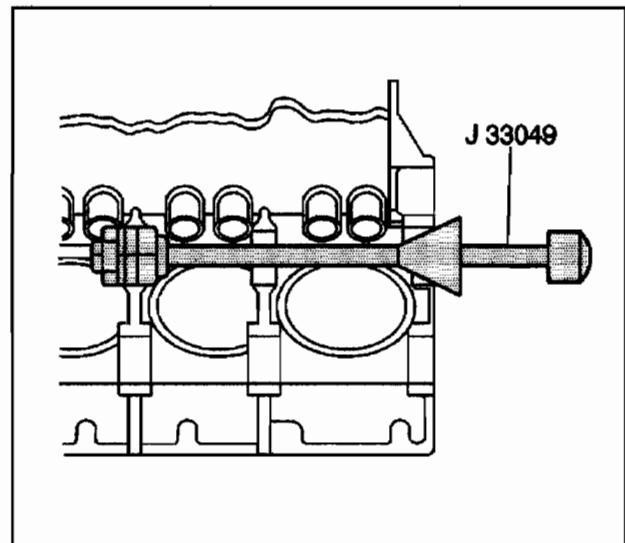
66100

Caution: Refer to Safety Glasses Caution in Cautions and Notices.

Important: A loose camshaft bearing may be caused by an enlarged, out-of-round, or damaged engine block camshaft bearing bore.

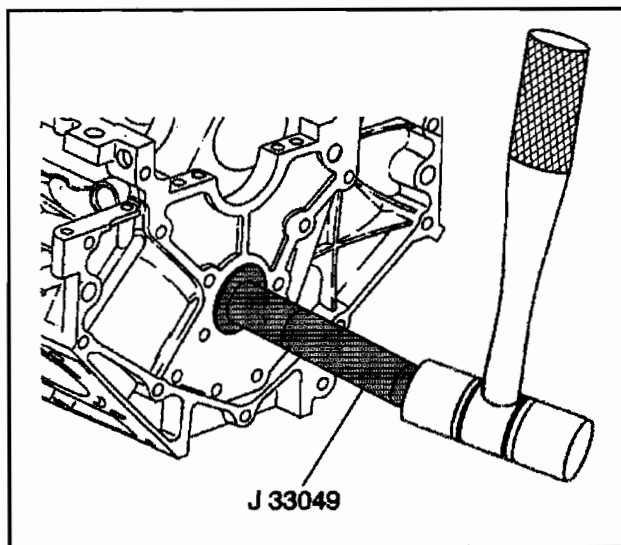
Important: Always remove the camshaft inner bearings #2, #3, and #4 first. The camshaft outer bearings #1 and #5 serve as a guide for the J 33049.

3. Remove the camshaft inner bearings #2, #3, and #4.
 - 3.1. Insert the J 33049 through the front of the engine block and into the camshaft inner bearing #2.
 - 3.2. Tighten the J 33049 expander assembly nut until snug.
 - 3.3. Push the J 33049 guide cone into the camshaft front bearing in order to align the J 33049.
 - 3.4. Drive the camshaft inner bearing #2 from the camshaft inner bearing bore #2.
 - 3.5. Loosen the J 33049 expander assembly nut.
 - 3.6. Remove the camshaft inner bearing #2 from the J 33049 expander assembly.
 - 3.7. Insert the J 33049 expander assembly into the camshaft inner bearing #3.
 - 3.8. Tighten the J 33049 expander assembly nut until snug.
 - 3.9. Push the J 33049 guide cone into the camshaft front bearing in order to align the J 33049.
 - 3.10. Drive the camshaft inner bearing #3 from the camshaft inner bearing bore #3.
 - 3.11. Loosen the J 33049 expander assembly nut.
 - 3.12. Remove the camshaft inner bearing #3 from the J 33049 expander assembly.
 - 3.13. Insert the J 33049 expander assembly into the camshaft inner bearing #4.

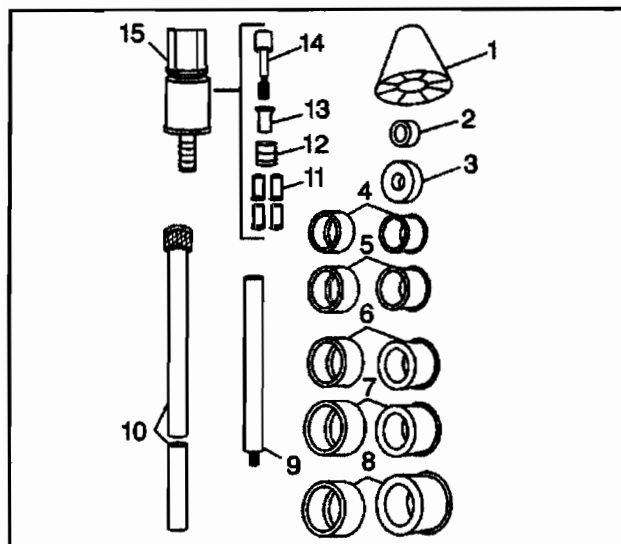


4985

- 3.14. Tighten the *J 33049* expander assembly nut until snug.
- 3.15. Push the *J 33049* guide cone into the camshaft front bearing in order to align the *J 33049*.
- 3.16. Drive the camshaft inner bearing #4 from the camshaft inner bearing bore #4.
- 3.17. Loosen the *J 33049* expander assembly nut.
- 3.18. Remove the camshaft inner bearing #4 from the *J 33049* expander assembly.
4. Remove the *J 33049* from the engine block.
5. Remove the camshaft outer bearings #1 and #5.
 - 5.1. Insert the *J 33049* into the camshaft outer bearing #1.
 - 5.2. Tighten the *J 33049* expander assembly nut until snug.
 - 5.3. Drive the camshaft outer bearing #1 from the camshaft outer bearing bore #1.
 - 5.4. Loosen the *J 33049* expander assembly nut.
 - 5.5. Remove the camshaft outer bearing #1 from the *J 33049* expander assembly.
 - 5.6. Remove the *J 33049* from the engine block.
 - 5.7. Insert the *J 33049* into the camshaft outer bearing #5.
 - 5.8. Tighten the *J 33049* expander assembly nut until snug.
 - 5.9. Drive the camshaft outer bearing #5 from the camshaft outer bearing bore #5.
 - 5.10. Loosen the *J 33049* expander assembly nut.
 - 5.11. Remove the camshaft outer bearing #5 from the *J 33049* expander assembly.
6. Remove the *J 33049* from the engine block.
7. Discard the camshaft bearings.



63219



66100

Camshaft Bearing Installation

SIE-ID = 195136

Tools Required

J 33049 Camshaft Bearing Service Kit

Important: Always install the camshaft outer bearings #1 and #5 first. The camshaft outer bearings serve as a guide for the *J 33049* and help center the camshaft inner bearings during the installation process.

Look to ensure that the camshaft bearing lubrication hole or holes align with the oil gallery hole or holes in the engine block. On some engines, the oil gallery holes may be difficult to see. Verify that the camshaft bearing lubrication holes and the oil gallery holes are aligned.

1. Assemble the *J 33049* handle (10), the expanding driver (4–8), the washer (2 or 3), and the expander assembly (15).

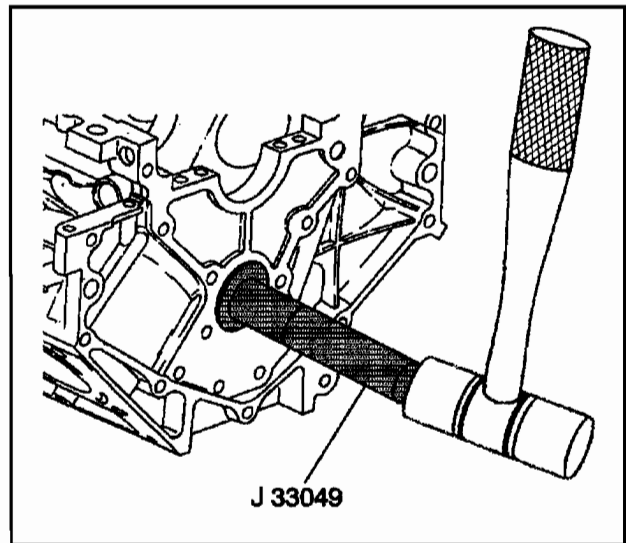
Caution: Refer to *Safety Glasses Caution in Cautions and Notices*.

Important: The camshaft bearing lubrication holes must align with the oil gallery holes in the engine block.

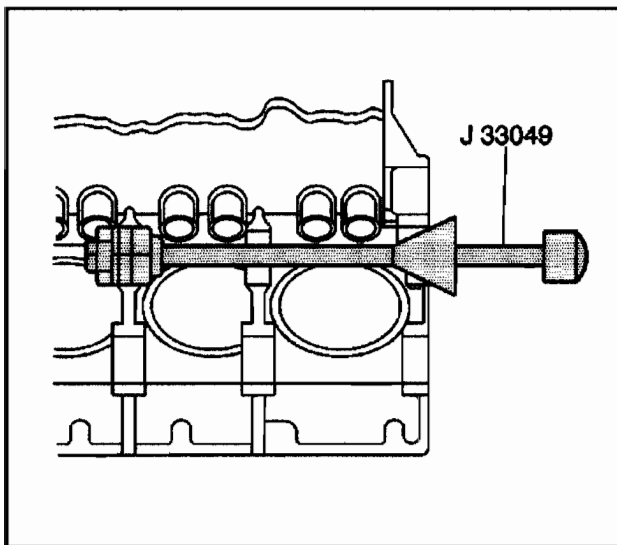
After installation of the camshaft bearings, always inspect the camshaft bearing lubrication holes for proper alignment with the oil gallery holes.

An improperly aligned camshaft bearing lubrication hole and oil gallery hole will restrict oil flow to the camshaft bearing and the camshaft journal.

2. Install the NEW camshaft outer bearings #5 and #1.
 - 2.1. Install the NEW camshaft outer bearing #5 onto the *J 33049* expander assembly.
 - 2.2. Tighten the *J 33049* expander assembly nut until snug.
 - 2.3. Align the camshaft outer bearing #5 lubrication hole with the oil gallery hole in the camshaft outer bearing bore #5 at the rear of the engine block.
 - 2.4. Drive the camshaft outer bearing #5 into the camshaft outer bearing bore #5 at the rear of the engine block.
 - 2.5. Loosen the *J 33049* expander assembly nut.
 - 2.6. Remove the *J 33049* expander assembly from the camshaft outer bearing #5.
 - 2.7. Install the NEW camshaft outer bearing #1 onto the *J 33049* expander assembly.
 - 2.8. Tighten the *J 33049* expander assembly nut until snug.
 - 2.9. Align the camshaft outer bearing #1 lubrication hole with the oil gallery hole in the camshaft outer bearing bore #1 at the front of the engine block.
 - 2.10. Drive the camshaft outer bearing #1 into the camshaft outer bearing bore #1 at the front of the engine block.
 - 2.11. Loosen the *J 33049* expander assembly nut.
 - 2.12. Carefully slide the *J 33049* into the engine block until the *J 33049* expander assembly is positioned between the camshaft inner bearing bores #3 and the camshaft inner bearing bore #4.



63219



4985

Important: The camshaft bearing lubrication holes must align with the oil gallery holes in the engine block. After installation of the camshaft bearings, always inspect the camshaft bearing lubrication holes for proper alignment with the oil gallery holes.

An improperly aligned camshaft bearing lubrication hole and oil gallery hole will restrict oil flow to the camshaft bearing and the camshaft journal.

3. Install the NEW camshaft inner bearings #4, #3, and #2.
 - 3.1. Install the NEW camshaft inner bearing #4 onto the J 33049 expander assembly.
 - 3.2. Tighten the J 33049 expander assembly nut until snug.
 - 3.3. Align the camshaft inner bearing #4 lubrication hole with the oil gallery hole in the camshaft inner bearing bore #4 of the engine block.
 - 3.4. Push the J 33049 guide cone into the camshaft front bearing bore #1 in order to align the J 33049.
 - 3.5. Drive the camshaft inner bearing #4 into the camshaft inner bearing bore #4.
 - 3.6. Loosen the J 33049 expander assembly nut.
 - 3.7. Carefully slide the J 33049 until the J 33049 expander assembly is positioned between the camshaft inner bearing bore #3 and the camshaft outer bearing bore #2.
 - 3.8. Install the NEW camshaft inner bearing #3 onto the J 33049 expander assembly.
 - 3.9. Tighten the J 33049 expander assembly nut until snug.
 - 3.10. Align the camshaft inner bearing #3 lubrication hole with the oil gallery hole in the camshaft inner bearing bore #3 of the engine block.
 - 3.11. Push the J 33049 guide cone into the camshaft front bearing bore #1 in order to align the J 33049.
 - 3.12. Drive the camshaft inner bearing #3 into the camshaft inner bearing bore #3.
 - 3.13. Loosen the J 33049 expander assembly nut.
 - 3.14. Carefully slide the J 33049 until the J 33049 expander assembly is positioned between the camshaft inner bearing bore #2 and the camshaft outer bearing bore #1.
 - 3.15. Install the NEW camshaft inner bearing #2 onto the J 33049 expander assembly.
 - 3.16. Tighten the J 33049 expander assembly nut until snug.
 - 3.17. Align the camshaft inner bearing #2 lubrication hole with the oil gallery hole in the camshaft inner bearing bore #2 of the engine block.
 - 3.18. Push the J 33049 guide cone into the camshaft front bearing bore #1 in order to align the J 33049.

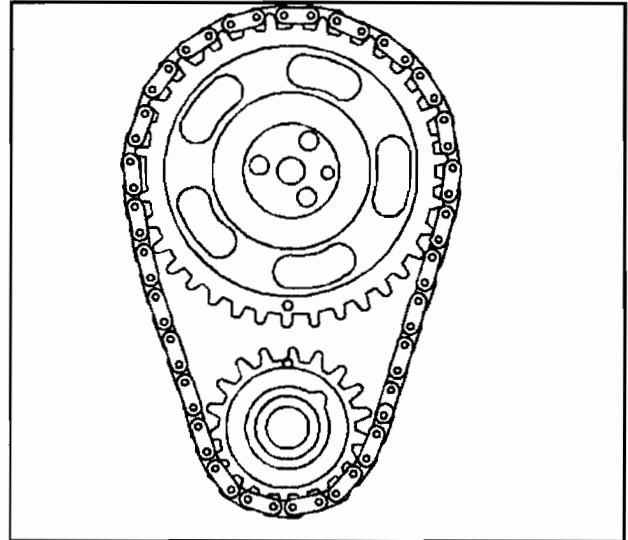
- 3.19. Drive the camshaft inner bearing #2 into the camshaft inner bearing bore #2.
- 3.20. Loosen the J 33049 expander assembly nut.
4. Carefully remove the J 33049 from the engine block.

Timing Chain and Sprockets Cleaning and Inspection

SIE-ID = 195154

Caution: Refer to Safety Glasses Caution in Cautions and Notices.

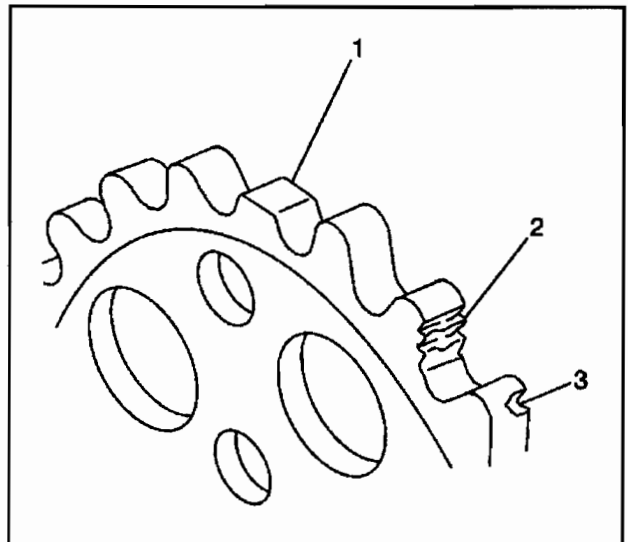
1. Clean the components in cleaning solvent.
2. Dry the components with compressed air.
3. Inspect the camshaft timing chain for binding or wear.



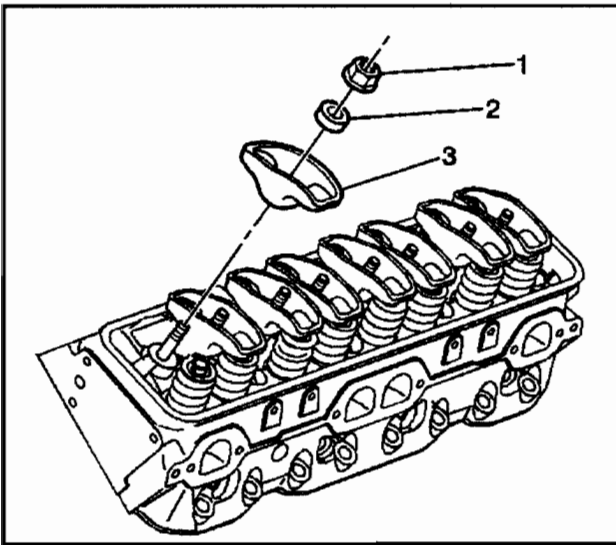
11503

4. Inspect the camshaft and crankshaft sprockets for:

- Broken teeth (1)
- Damaged teeth (2)
- Chipped teeth (3)
- Worn teeth
- Uneven wear on one edge of the teeth
- Worn valleys between the sprocket teeth
- Crankshaft sprocket keyway for wear
- Crankshaft sprocket woodruff key for wear or damage



188097



182835

Valve Rocker Arm and Push Rods Cleaning and Inspection

SIE-ID = 195201

Important: Parts that are to be reused must be marked, sorted and organized for assembly.

1. Mark, sort, and organize the components for assembly.

Caution: Refer to *Safety Glasses Caution in Cautions and Notices*.

2. Clean the components with cleaning solvent.
3. Dry the components with compressed air.
4. Inspect the valve rocker arm components for the following:

- Wear or scoring of the valve rocker arm (3) ball area
- Valve rocker arm (3) pushrod sockets and valve stem contact surfaces

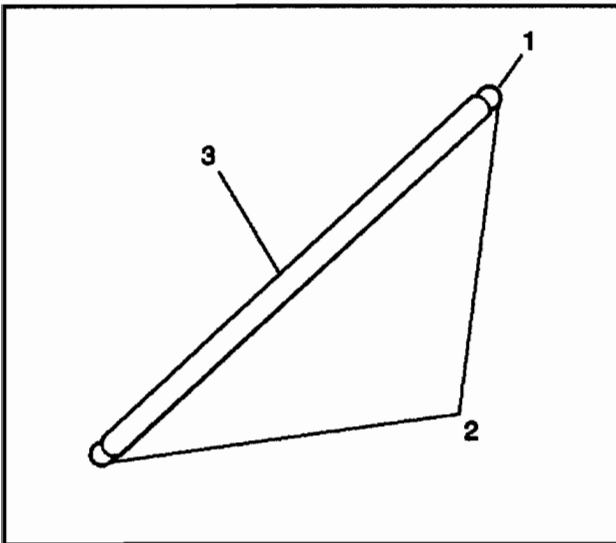
The contact surfaces should be smooth with no scoring or excessive wear.

- Valve rocker arm ball (2) for wear or scoring
The contact surface must be smooth with no scoring or excessive wear.

5. Inspect the valve pushrods for the following:

- Restriction of the oil passage (1)
- Wear or scoring of the end contact surfaces (2)
The end contact surfaces must be smooth with no scoring or excessive wear.
- Shaft for bends (3)

Roll the valve pushrod on a flat surface to determine if the valve pushrod is bent.



488857

Valve Lifters and Guides Cleaning and Inspection

SIE-ID = 195248

Caution: Refer to Safety Glasses Caution in Cautions and Notices.

Important: Components that are to be reused must be marked, sorted, and organized for assembly.

1. Mark, sort, and organize the components for assembly.
2. Clean the components in cleaning solvent.
3. Dry the components with compressed air.
4. Inspect the valve lifter for the following:

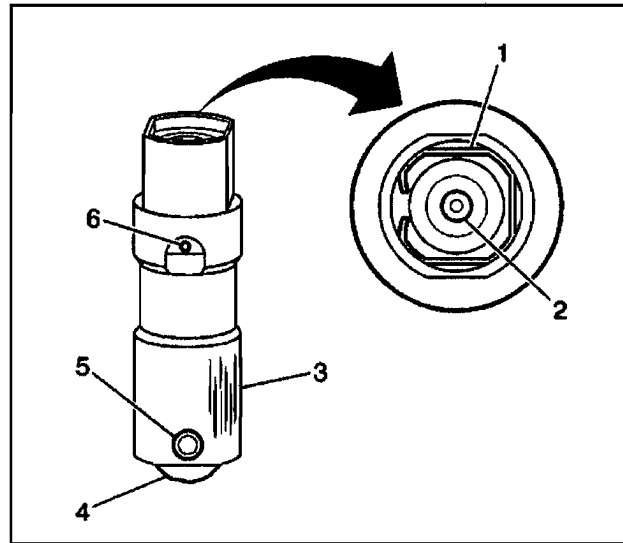
- Broken or damaged clip (1)
- Worn valve pushrod socket (2)
- Wear or scuffing (3)
- If the valve lifter shows wear or scuffing, inspect the engine block valve lifter bores for wear or damage.
- Worn roller (4)
- Loose or damaged pin (5)
- Plugged oil hole (6)

5. Inspect the valve lifter guides (1) for the following:

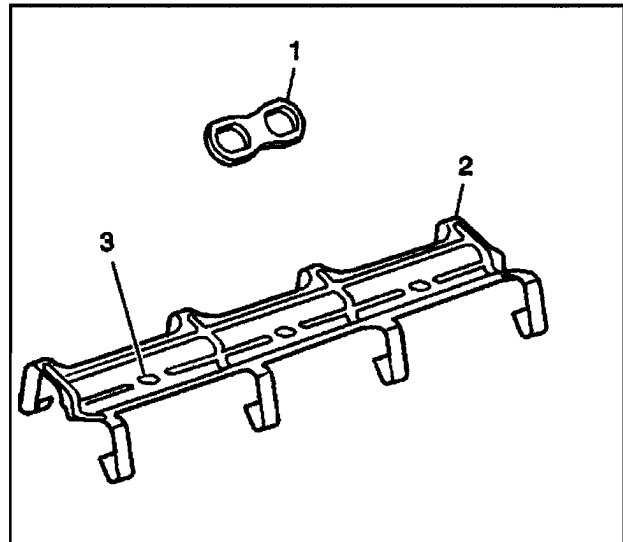
- Excessive wear (1)
- Cracks or damage

6. Inspect the valve lifter guide retainer for:

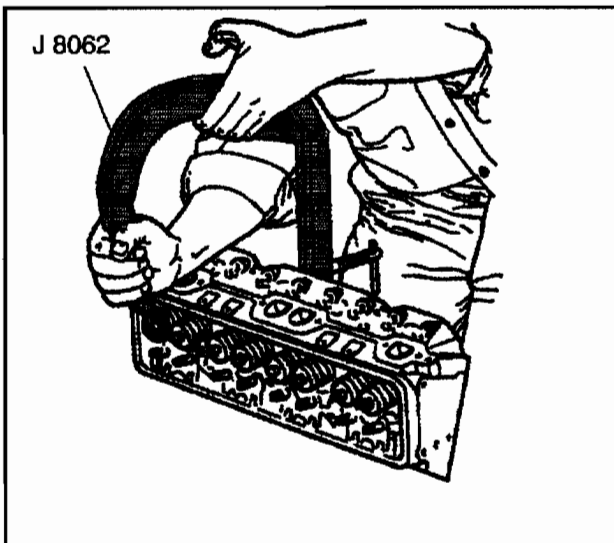
- Wear, damage, or stress cracking in the leg areas (2)
- Wear or damage in the bolt holes (3)



178485



521834



34468

Cylinder Head Disassemble

SIE-ID = 195340

Tools Required

J 8062 Valve Spring Compressor

Caution: SIO-ID = 411484 Compressed valve springs have high tension against the valve spring compressor. Valve springs that are not properly compressed by or released from the valve spring compressor can be ejected from the valve spring compressor with intense force. Use care when compressing or releasing the valve spring with the valve spring compressor and when removing or installing the valve stem keys.

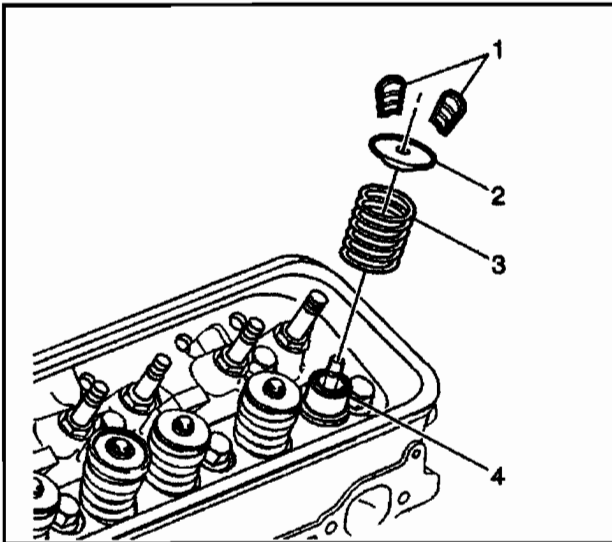
Caution: Failing to use care may cause personal injury.

Caution: Refer to Safety Glasses Caution in Cautions and Notices.

1. Use the J 8062 in order to compress the valve springs.

Important: Place the valves in a rack, in the proper sequence, so that the valves can be installed in the same order as the valve were removed.

2. Remove the valve stem keys (1).
3. Remove the J 8062 from the cylinder head.
4. Remove the valve spring cap (2).
5. Remove the valve spring (3).
6. Remove the valve stem oil seal (4).
7. Discard the valve stem oil seal (4).
8. Remove the valve.



334505

Cylinder Head Cleaning and Inspection

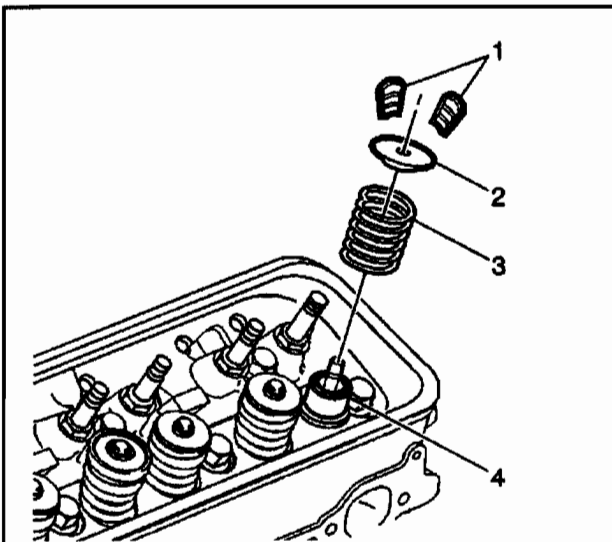
SIE-ID = 799092

Tools Required

- J 8001 Dial Indicator Set
- J 8089 Carbon Removing Brush
- J 9666 Valve Spring Tester

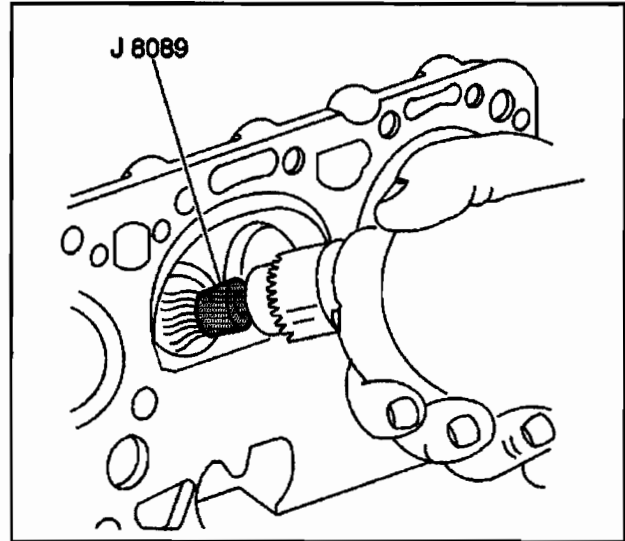
Caution: Refer to Safety Glasses Caution in Cautions and Notices.

1. Clean the valve stems and cylinder heads on a buffing wheel.
2. Clean the following components in cleaning solvent:
 - Valve stem keys (1)
 - Valve spring cap (2)
 - Valve spring (3)
 - Cylinder head



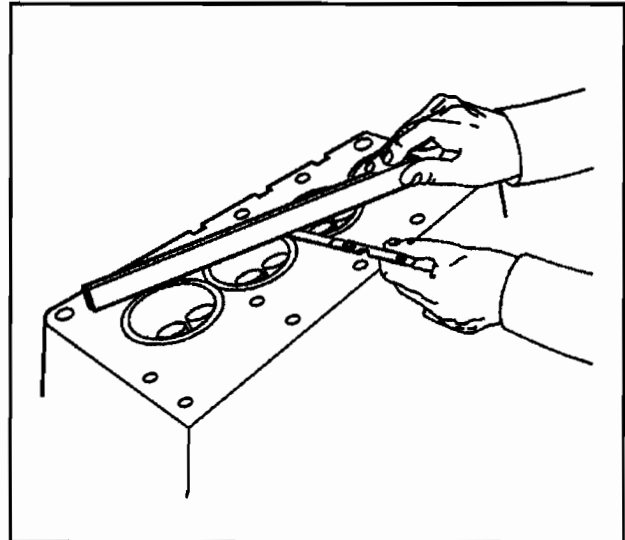
334505

3. Dry the components with compressed air.
4. Use the *J 8089* to clean the carbon from the cylinder head combustion chambers.
Be careful not to scuff the combustion chambers.
5. Inspect the cylinder head for the following:
 - Damage to the gasket surfaces
 - Damage to the threaded bolt holes
 - Burnt or eroded areas in the combustion chamber
 - Cracks in the exhaust ports and combustion chambers
 - External cracks in the water chamber
 - Restrictions in the intake or exhaust passages
 - Restrictions in the cooling system passages
 - Rusted, damaged, or leaking core plugs

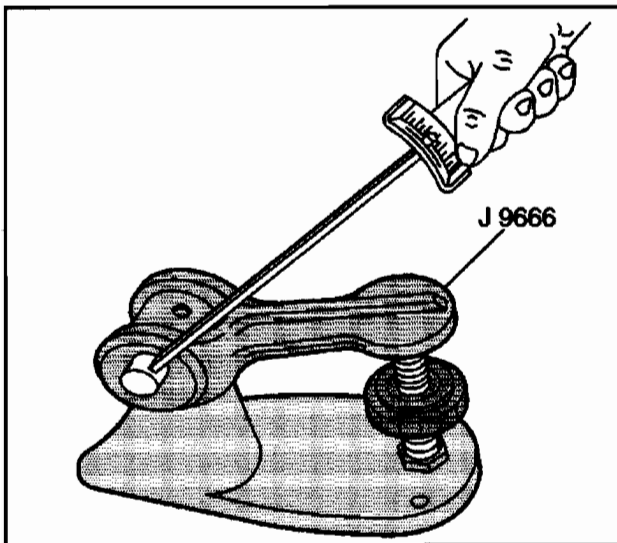


4957

6. Measure the cylinder head for warpage with a straight edge and feeler gage.
 - A cylinder head block deck with warpage in excess of 0.10 mm (0.004 in) within a 152.4 mm (6.0 in) area must be repaired or replaced.
 - A cylinder head exhaust manifold deck with warpage in excess of 0.05 mm (0.002 in) must be repaired or replaced.
 - A cylinder head intake manifold deck with warpage in excess of 0.10 mm (0.004 in) must be repaired or replaced.



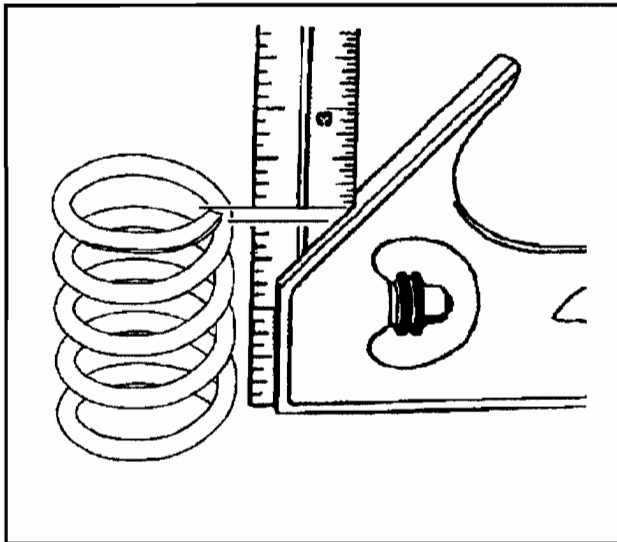
64318



4960

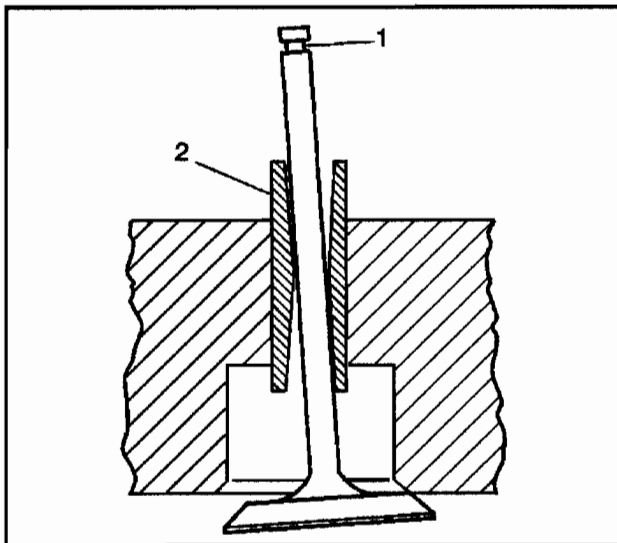
7. Use the *J 9666* in order to measure the valve spring.

Replace the valve spring if the valve spring tension is less than 338 N (76 lb) at 43.2 mm (1.70 in).



40075

8. Inspect the valve springs for squareness.

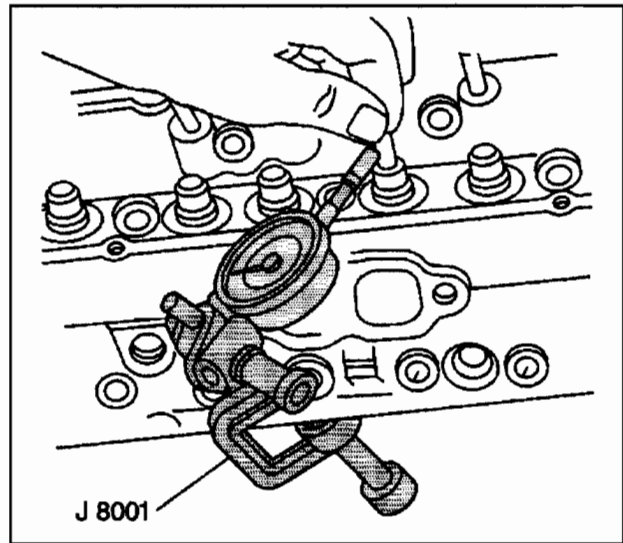


156172

9. Valve stems (1) with excessive guide (2) clearance must be repaired or replaced.

10. Measure the valve stem-to-guide clearance.
Excessive valve stem-to-guide clearance may cause an excessive oil consumption and may also cause a valve to break. Insufficient clearance will result in noisy and sticky functioning of the valve and will disturb the engine assembly smoothness.
- 10.1. Clamp the *J 8001* on the exhaust port side of the cylinder head.
 - 10.2. Locate the dial indicator so that the movement of the valve stem from side to side, crosswise to the cylinder head, will cause a direct movement of the dial indicator stem.

The dial indicator stem must contract the side of the valve stem just above the valve guide.
 - 10.3. Drop the valve head about 1.6 mm (0.063 in) off the valve seat.
 - 10.4. Use light pressure and then move the valve stem from side to side in order to obtain a clearance reading. Refer to *Engine Mechanical Specifications (5.0 L)* or *Engine Mechanical Specifications (5.7 L)*.



35214

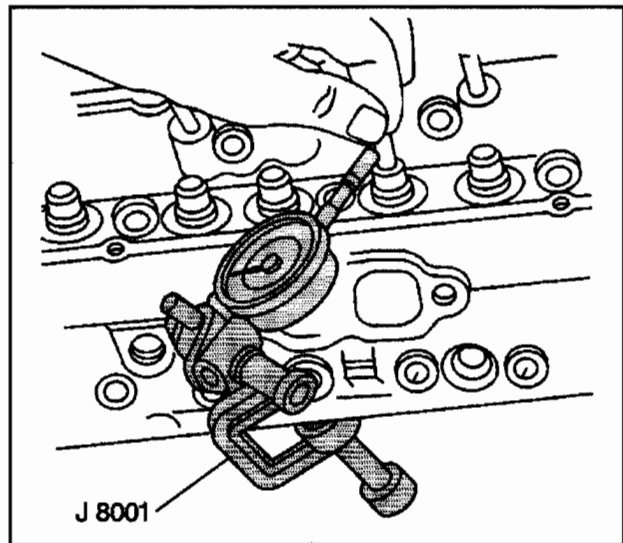
Valve Guide Reaming/Valve and Seat Grinding

SIE-ID = 784242

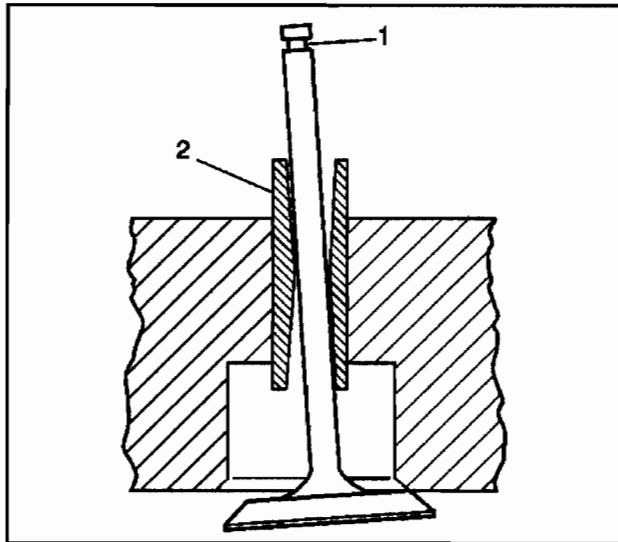
Tools Required

- *J 5830-02* Valve Guide Reamer Set
- *J 8001* Dial Indicator Set

1. Measure the valve stem-to-guide clearance.
Refer to *Cylinder Head Cleaning and Inspection*.

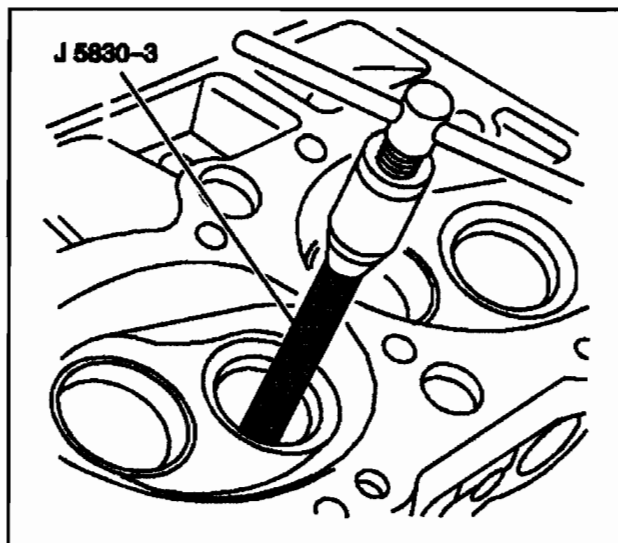


35214



156172

2. Improper valve stem (1) to valve guide (2) clearance may cause excessive oil consumption.

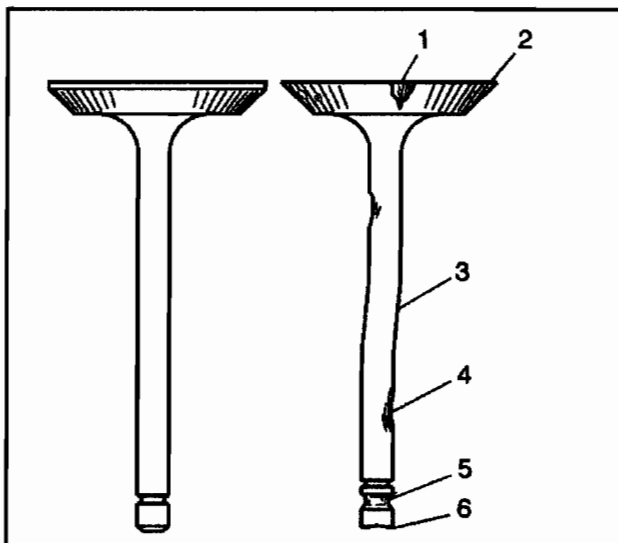


480556

Caution: Refer to Safety Glasses Caution in Cautions and Notices.

Important: Exhaust valves with excessive valve stem-to-guide clearance must be replaced with the available service valve that has an 0.774 mm (0.0305 in) oversize valve stem. The intake valves are NOT available with oversize valve stems. Replace the cylinder head if after using a NEW intake valve in order to measure the valve stem-to-guide clearance, the valve stem-to-guide clearance is not within specifications.

3. Use the J 5830-3 in order to ream the exhaust valve guide in order to achieve the correct valve stem-to-guide clearance.
4. Always recondition the exhaust valve seat after reaming the exhaust valve guide bores and installing new exhaust valves.



156174

5. Inspect the valves for the following:
 - Burnt or damaged areas (1)
 - Undersized margin (2)
 - Bent stem (3)
 - Scoring or other damage to the stem (4)
 - Worn key groove (5)
 - Worn stem tip (6)

6. Inspect the valve contact surface for the following:

- Undersized margin (1)
- Pitted surface (2)
- Burnt or eroded areas (3)
- Acceptable edge (margin) (4)

Valves with excessive damage must be replaced.

Minor imperfections of the valve or valve seat may be repaired.

7. Reconditioning of the valves and valve seats:

- The valves must seat perfectly for the engine to deliver optimum power and performance.
- Cooling the valve heads is another important factor. Good contact between each valve and valve seat in the cylinder head is necessary to insure that the heat in the valve head is properly carried away.
- Regardless of what type of equipment is used, it is essential that the valve guide bores are free from carbon or dirt in order to ensure the proper centering of the pilot in the valve guide.

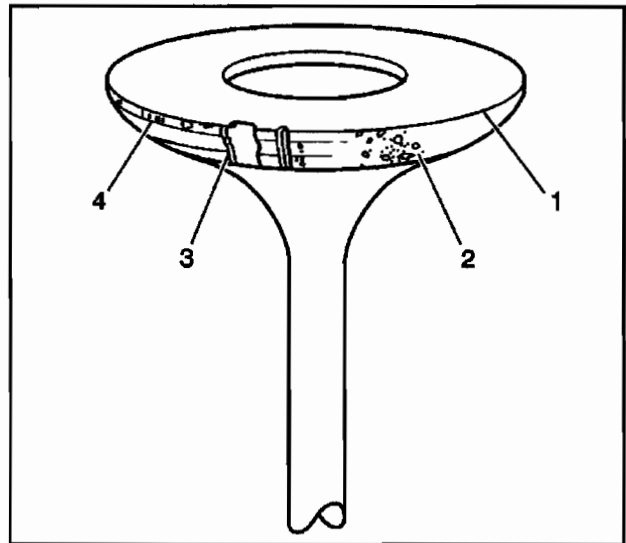
The valve seats should be concentric to within 0.05 mm (0.002 in) total indicator reading.

- Reface pitted valves on a valve refacing machine in order to ensure the correct relationship between the valve head and the valve stem.

Replace the valve if the valve stem is excessively worn or warped.

Replace the valve if the edge of the valve head is less than 0.79 mm (0.031 in) thick after grinding.

- Several different types of equipment are available for reconditioning valves and valve seats. Follow the equipment manufacturer's recommendations for equipment use to attain the proper results.



156173

Valve Rocker Arm Stud Removal

SIE-ID = 195352

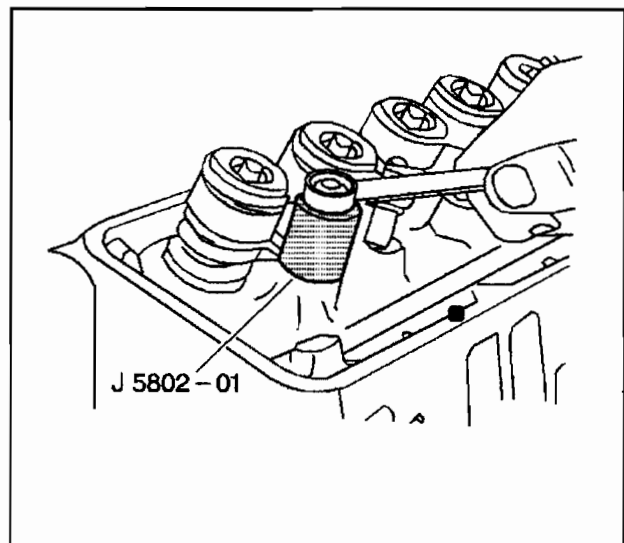
Tools Required

J 5802-01 Rocker Arm Stud Remover

Important:

- Valve rocker arm ball studs that have damaged threads, or are loose in cylinder heads, should be replaced.
- Valve rocker arm ball studs are pressed into the cylinder head.
- New valve rocker arm ball studs are available in 0.0762 mm (0.003 in) and 0.3302 mm (0.013 in) oversize.

1. Place the J 5802-01 over the valve rocker arm ball stud to be removed.
2. Install a nut and a flat washer.



66507

3. Rotate the nut clockwise to remove the valve rocker arm ball stud.

Valve Rocker Arm Stud Installation

SIE-ID = 195354

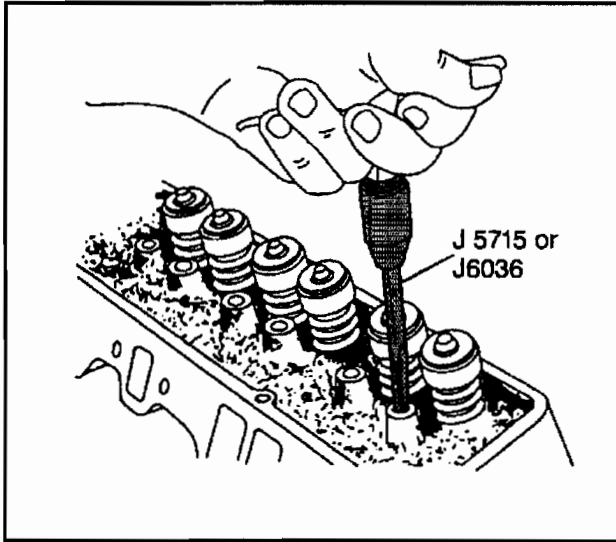
Tools Required

- J 5715 Reamer (0.0762 mm (0.003 in))
- J 6036 Reamer (0.03302 mm (0.013 in))
- J 6880 Rocker Arm Stud Installer

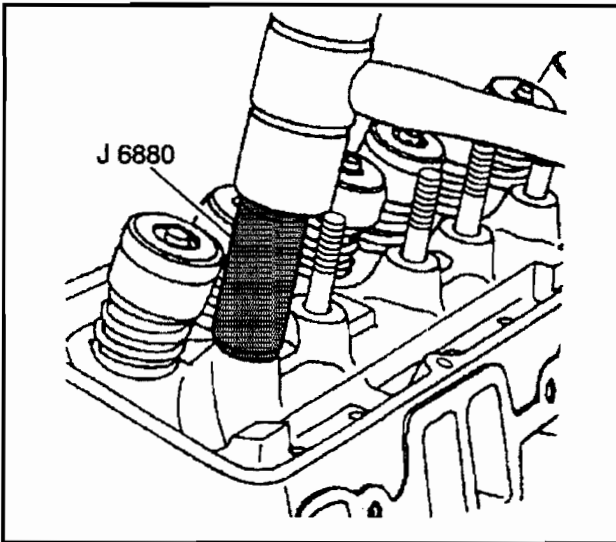
Caution: Refer to *Safety Glasses Caution in Cautions and Notices*.

Important: Valve rocker arm ball studs that have damaged threads or are loose in cylinder heads should be replaced. New valve rocker arm ball studs are available in 0.0762 mm (0.003 in) and 0.3302 mm (0.013 in) oversize.

1. Ream the hole to the proper size for the replacement oversize valve rocker arm ball stud. Use J 5715 for 0.0762 mm (0.003 in) oversize valve rocker arm ball studs, or J 6036 for 0.3302 mm (0.013 in) oversize valve rocker arm ball studs.
2. Apply lubricant GM P/N United States 1052271, GM P/N Canada 10950849, or equivalent, the lower end, press-fit end, of the valve rocker arm ball stud.
3. Use the J 6880 and a hammer to install the valve rocker arm ball stud into place. The valve rocker arm ball stud is installed to proper depth when the J 6880 bottoms onto the cylinder head.



66509



66504

Cylinder Head Assemble

SIE-ID # 195342

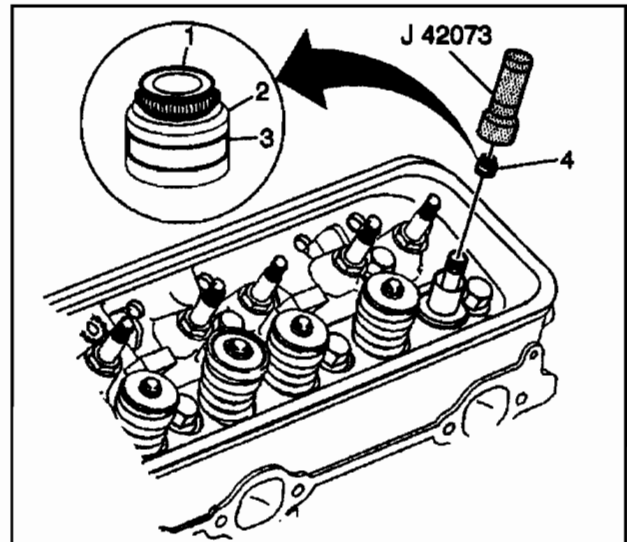
Tools Required

- J 8062 Valve Spring Compressor
- J 42073 Valve Stem Seal Installer

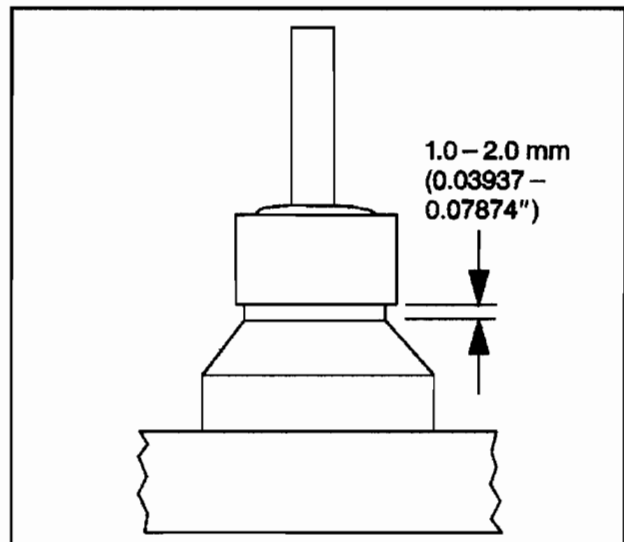
Caution: Refer to Safety Glasses Caution in Cautions and Notices.

Important: The exhaust valve oil stem seal has the letters EX (1) molded into the top of the seal. The exhaust valve oil stem seal material is brown in color (2) with a white stripe (3) painted onto the outside diameter of the seal, or the material may be red in color (2) with no paint stripe. The intake valve stem oil seal is black in color.

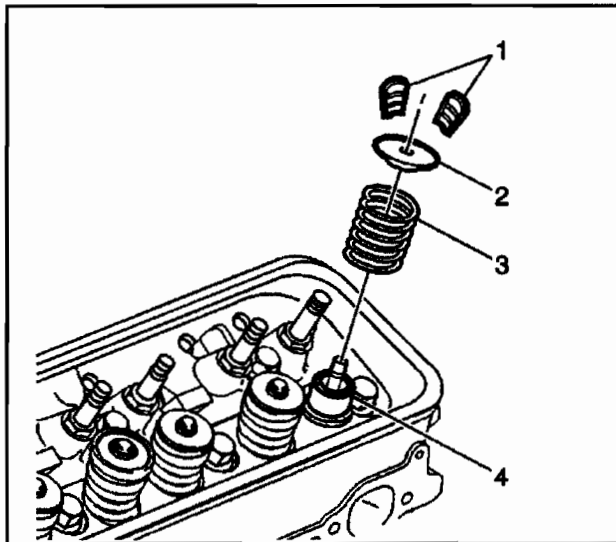
1. Lubricate the valve stem and assemble the valve into the proper valve guide.
2. Select the proper valve stem oil seal for the specific valve guide.
3. Lubricate the valve stem oil seal and guide with clean engine oil.
4. Assemble the valve stem oil seal onto the valve stem.
5. Using the J 42073, install the valve stem oil seal onto the valve guide.
 - 5.1. Tap the valve stem oil seal onto the valve guide until the J 42073 bottoms against the valve spring seat.
 - 5.2. Inspect the valve stem oil seal. The valve stem oil seal should not be bottomed against the valve guide.
There should be a 1–2 mm (0.03937–0.07874 in) gap between the bottom edge of the valve stem oil seal and the valve guide.



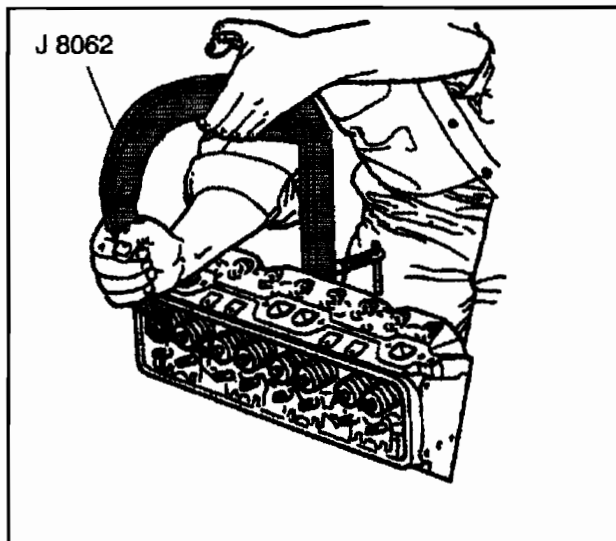
200320



36373



334505



34468

6. Install the valve spring (3).
7. Install the valve spring cap (2) onto the valve spring (3), over the valve stem.

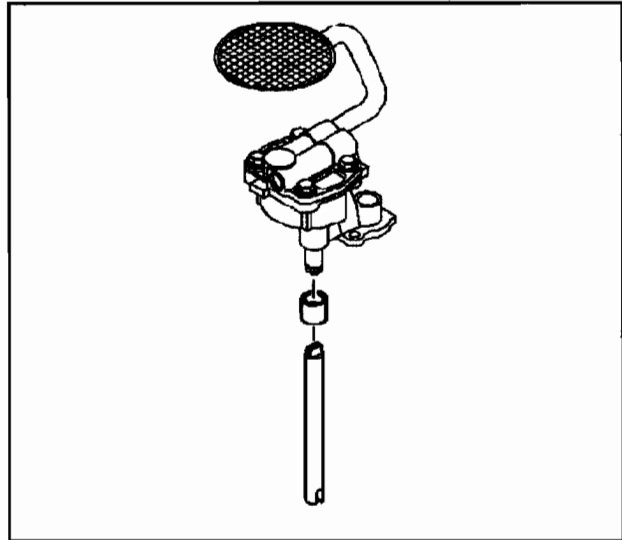
Caution: SIC-ID = 411464 *Compressed valve springs have high tension against the valve spring compressor. Valve springs that are not properly compressed by or released from the valve spring compressor can be ejected from the valve spring compressor with intense force. Use care when compressing or releasing the valve spring with the valve spring compressor and when removing or installing the valve stem keys. Failing to use care may cause personal injury.*

8. Use the J 8062 to compress the valve spring.
9. Install the valve stem O-ring seal.
10. Install the valve stem keys.
 - 10.1. Use grease to hold the valve stem keys in place while disconnecting the J 8062.
 - 10.2. Tap the end of the valve stem with a plastic-faced hammer to seat the valve stem keys.
 - 10.3. Inspect the valve stem keys to ensure that they are seated in the upper groove of the valve stem.

Oil Pump Disassemble

S/E-ID = 195049

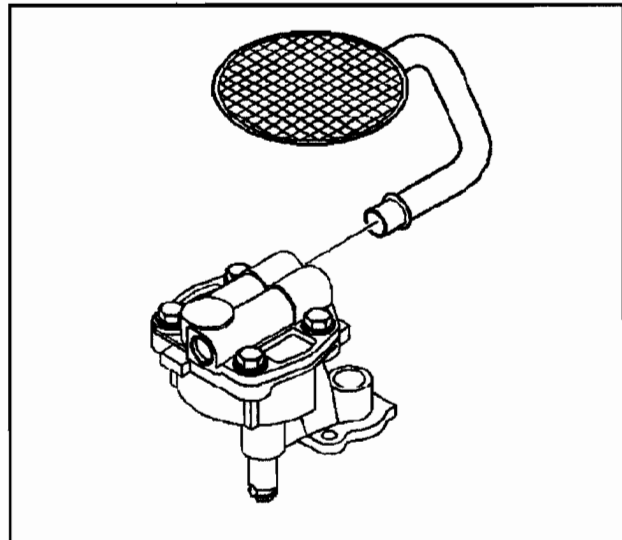
1. Remove the oil pump driveshaft and oil pump driveshaft retainer.



5274

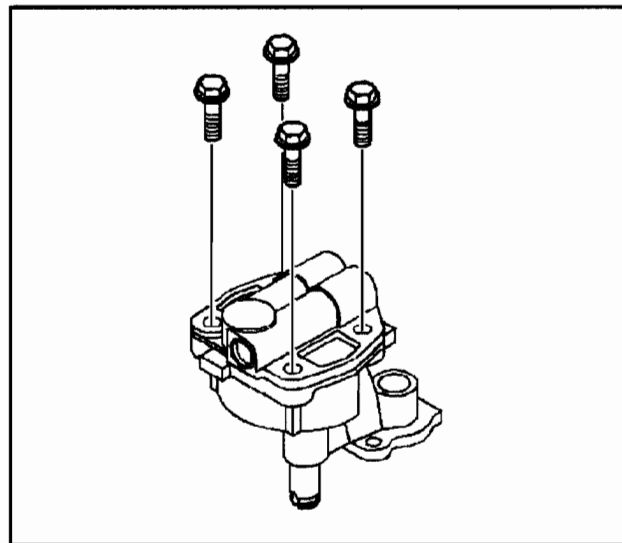
Important: Do not remove the oil pump screen from the pipe. The pipe and oil pump screen are serviced as a complete assembly.

2. Remove the oil pump screen, if necessary. The oil pump screen has a press fit into the oil pump cover.

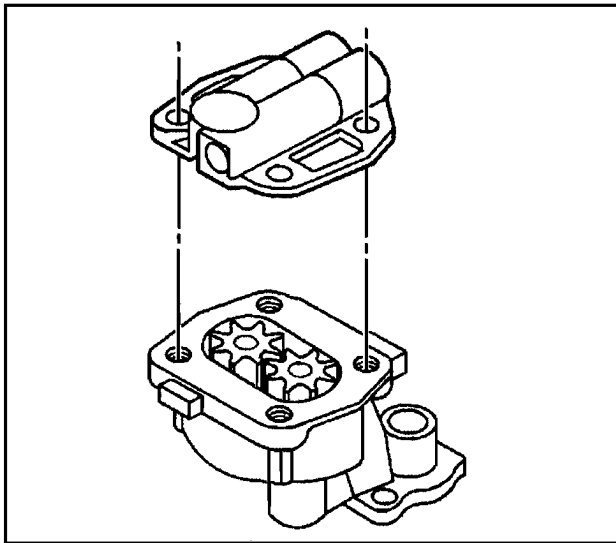


5275

3. Remove the oil pump cover bolts.

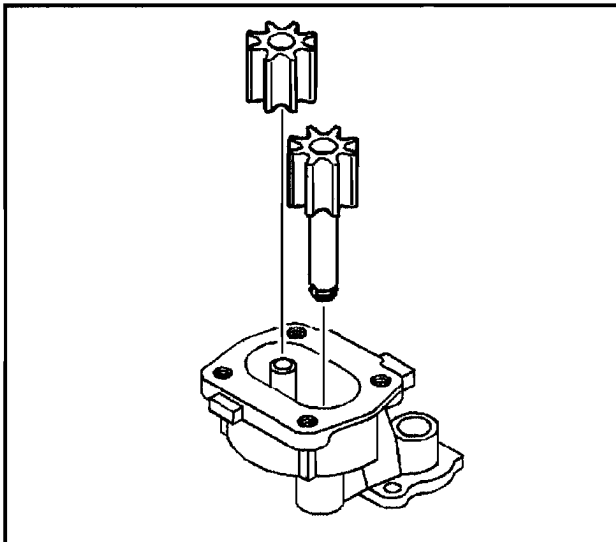


5276



5277

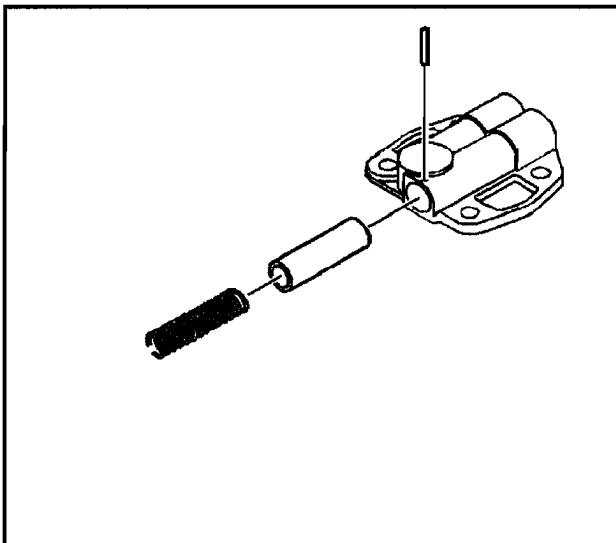
4. Remove the oil pump cover.



5278

5. Remove the oil pump drive gear and the oil pump driven gear.

6. Matchmark the gear teeth for assembly.



30401

Caution: Refer to Safety Glasses Caution in Cautions and Notices.

7. Remove the following items:

- 7.1. The oil pump pressure relief valve spring straight pin
- 7.2. The oil pump pressure relief spring
- 7.3. The oil pump pressure relief valve

Oil Pump Cleaning and Inspection

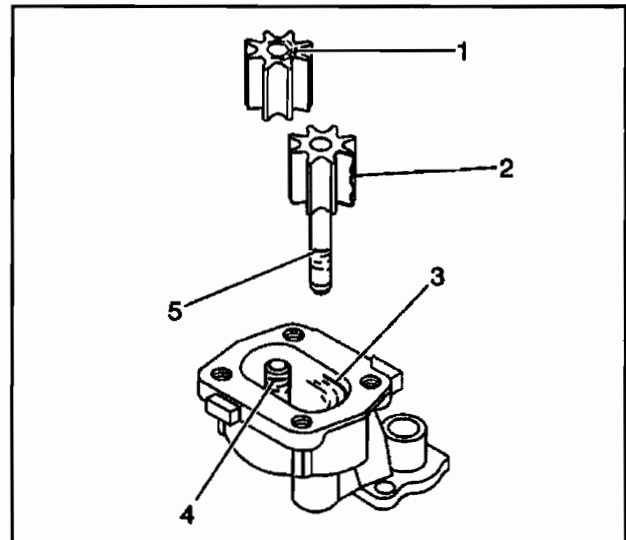
SIE-ID = 35473

Caution: Refer to Safety Glasses Caution in Cautions and Notices.

1. Clean the oil pump components in cleaning solvent.
2. Dry the components with compressed air.
3. Inspect the oil pump for the following conditions:
 - Scoring on the top of the gears (1)
 - Damaged gears (2) for the following:
 - Chipping
 - Galling
 - Wear
 - Scoring, damage or casting imperfections to the body (3)
 - Damaged or scored gear shaft (4)
 - Damaged or scored gear shaft (5)
 - Damaged bolt hole threads
 - Worn oil pump driveshaft bore
 - Damaged or sticking oil pump pressure relief valve

Minor imperfections may be removed with a fine oil stone.

 - Collapsed or broken oil pump pressure relief valve spring
4. If the oil pump is to be reused, install a NEW oil pump pressure relief valve spring.
5. During oil pump installation, install a NEW oil pump driveshaft retainer.



186750

Oil Pump Assemble

SIE-ID = 389671

Tools Required

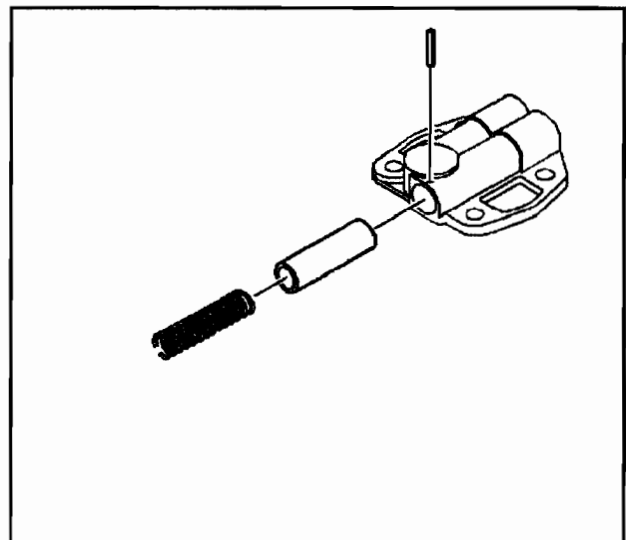
J 21882 Oil Suction Pipe Installer

1. Apply clean engine oil GM P/N United States 12345610, GM P/N Canada 993193, or equivalent, to the oil pump pressure relief valve, oil pump pressure relief valve spring, and oil pump body.

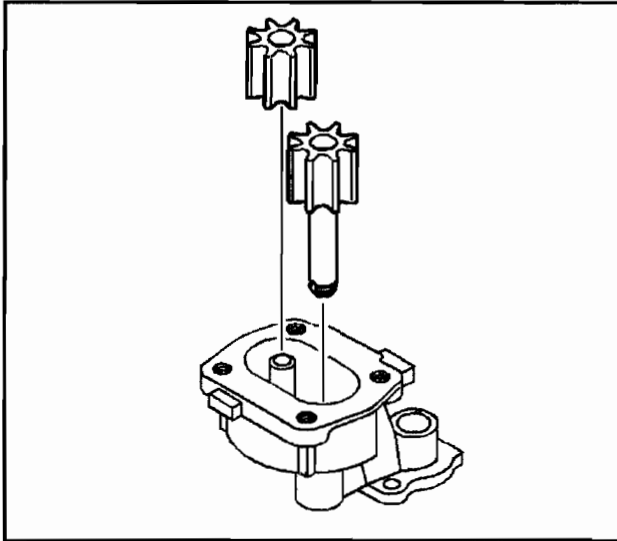
Caution: Refer to Safety Glasses Caution in Cautions and Notices.

Important: Replace the oil pump pressure relief valve spring when you reuse the oil pump.

2. Install the following items:
 - 2.1. The oil pump pressure relief valve
 - 2.2. The oil pump pressure relief valve spring
 - 2.3. The oil pump pressure relief valve spring straight pin

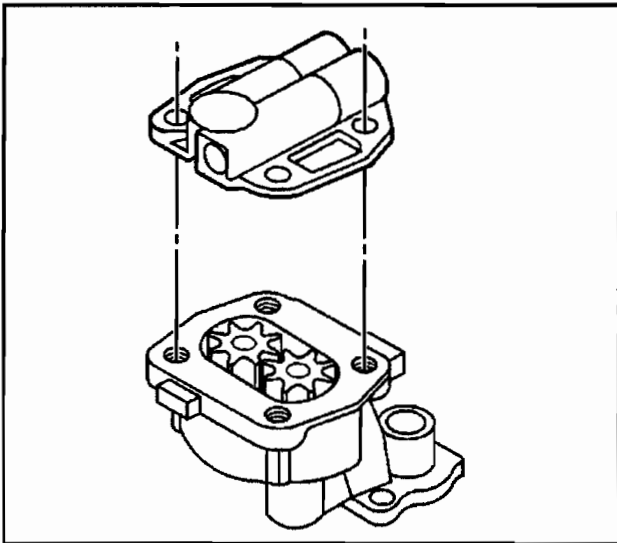


30401



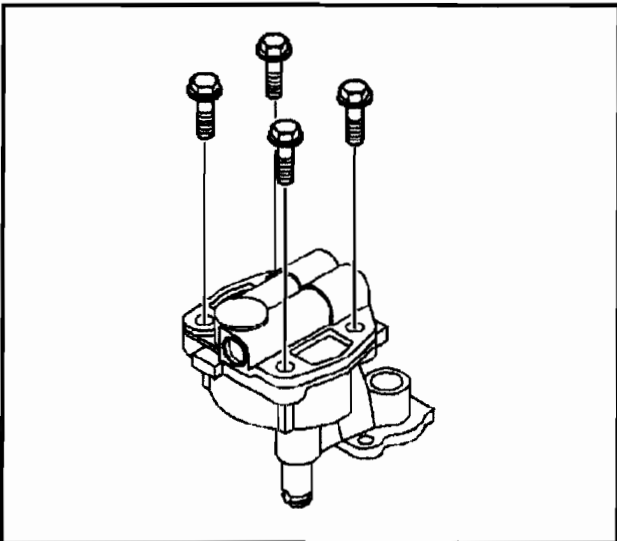
5278

3. Apply clean engine oil GM P/N United States 12345610, GM P/N Canada 993193, or equivalent, to the oil pump drive gear, the oil pump driven gear, and the oil pump body internal surfaces.
4. Install the oil pump drive gear and the oil pump driven gear into the oil pump body.
 - 4.1. Align the matchmarks on the oil pump drive and driven gears.
 - 4.2. Install the smooth side of the oil pump drive and driven gears toward the oil pump cover.



5277

5. Install the oil pump cover.



5276

Notice: Refer to *Fastener Notice* in Caution and Notices.

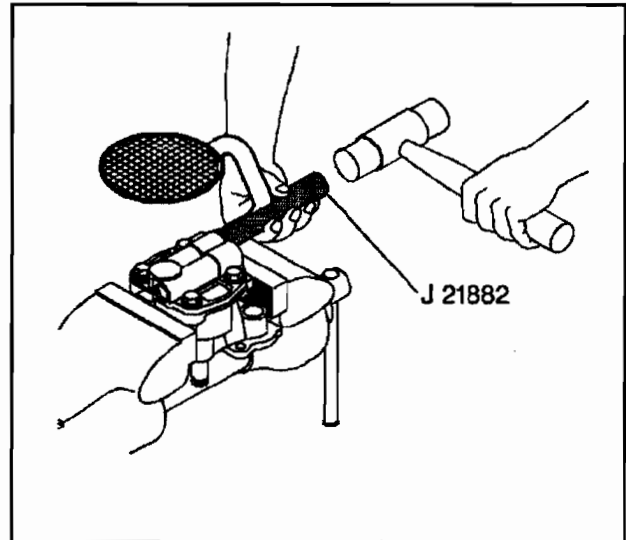
6. Install the oil pump cover bolts.

Tighten

Tighten the bolts to 12 N·m (106 lb in).

7. Inspect the oil pump for smoothness of operation by turning the oil pump driveshaft by hand.

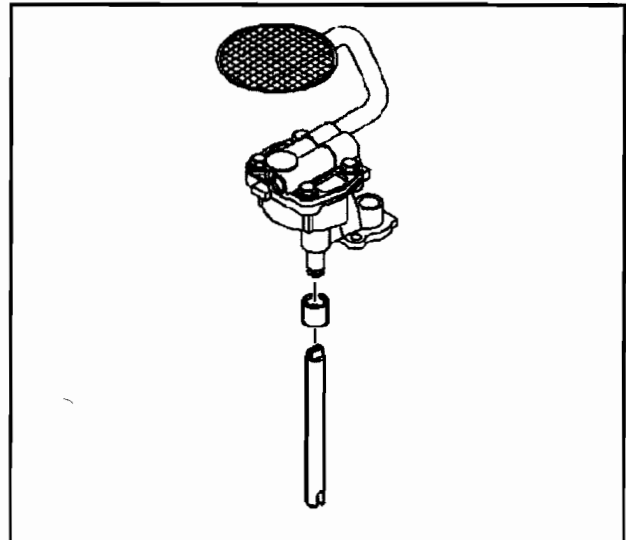
8. Install the oil pump screen.
 - 8.1. If removed, replace the oil pump screen. The oil pump screen must have a good press fit into the oil pump body.
 - 8.2. Mount the oil pump in a soft jawed vise.
 - 8.3. Apply sealant GM P/N United States 12346004, GM P/N Canada 10953480, or equivalent, to the end of the oil pump screen pipe.
 - 8.4. Use the *J 21882* and a soft-faced hammer in order to tap the oil pump screen into the pump body.
The oil pump screen must align parallel with the bottom of the oil pan when the oil pan is installed.



5280

Important: Install a NEW oil pump driveshaft retainer during assembly.

9. Install the oil pump driveshaft and the NEW oil pump driveshaft retainer.



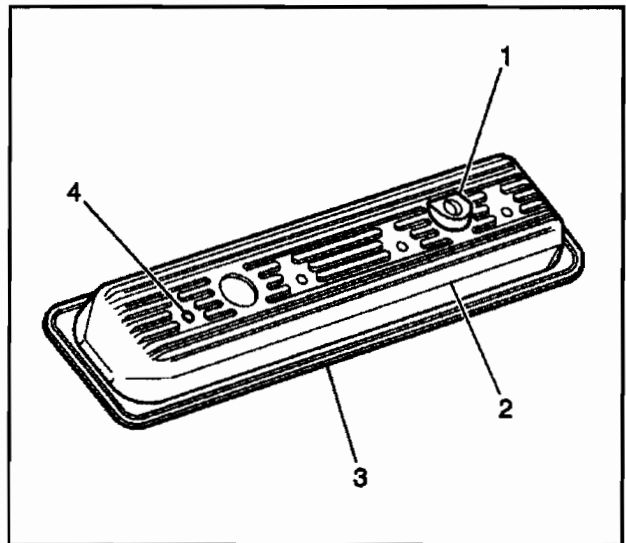
5274

Valve Rocker Arm Cover Cleaning and Inspection

SIE-ID = 195020

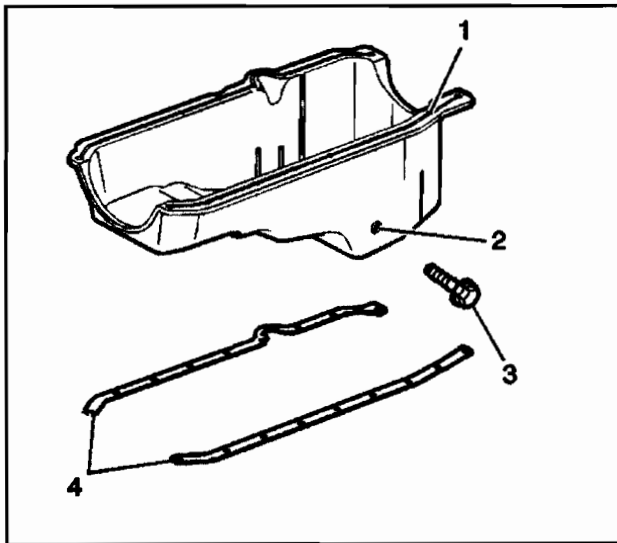
Caution: Refer to Safety Glasses Caution in Cautions and Notices.

1. Clean the valve rocker arm cover in cleaning solvent.
2. Dry the valve rocker arm cover with compressed air.
3. Inspect the valve rocker arm cover for the following:
 - Damage to the PCV valve grommet (1)
 - Dents or damage to the exterior of the valve rocker arm cover (2)
 - A dented or damaged cover may interfere with the valve rocker arms.
 - Gouges or damage to the sealing surface (3)



333657

- Damage to the bolt holes (4)
- Restrictions to the ventilation system passages



521835

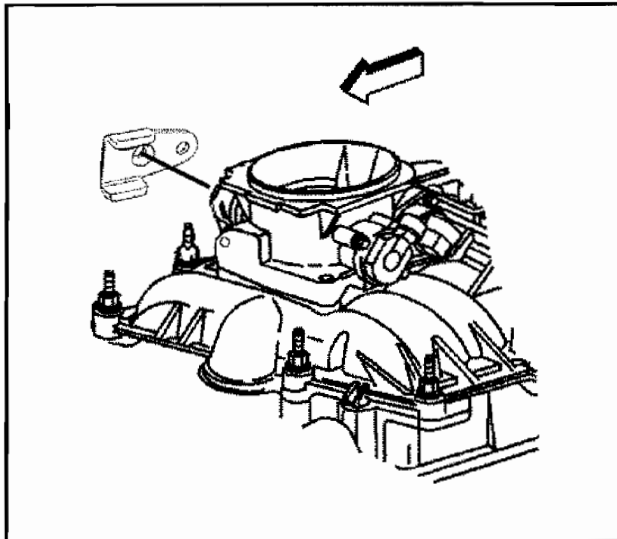
Oil Pan Cleaning and Inspection

SIE-ID = 194998

Caution: Refer to Safety Glasses Caution in Cautions and Notices.

1. Clean the oil pan in cleaning solvent.
2. Dry the oil pan with compressed air.
3. Inspect the oil pan for the following:
 - Gouges or damage to the oil pan sealing surfaces (1)
 - The oil pan drain plug hole for damaged threads (2)
 - Damage to oil pan drain plug threads (3)
 - Damage to the oil pan reinforcements (4)
 - Damage to the oil pan baffle
 - Dents or damage to the exterior of the oil pan

An oil pan that is dented may interfere with the position of the oil pump screen or not distribute oil properly in the oil pan sump area.



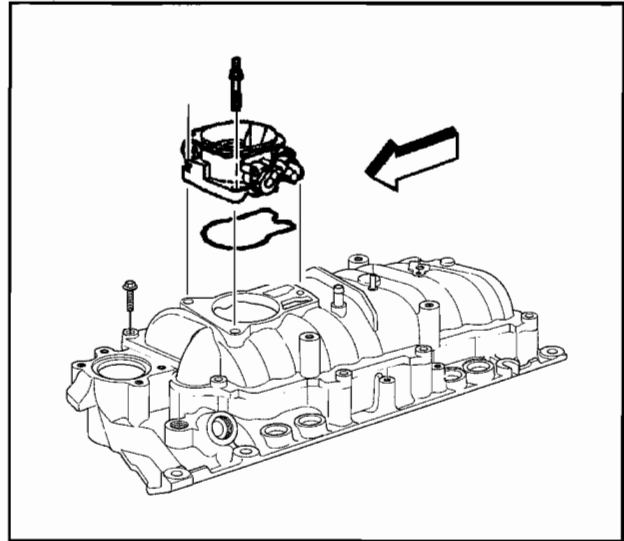
500661

Intake Manifold Disassemble

SIE-ID = 193478

1. Remove the bolt and the Throttle Extension bracket.

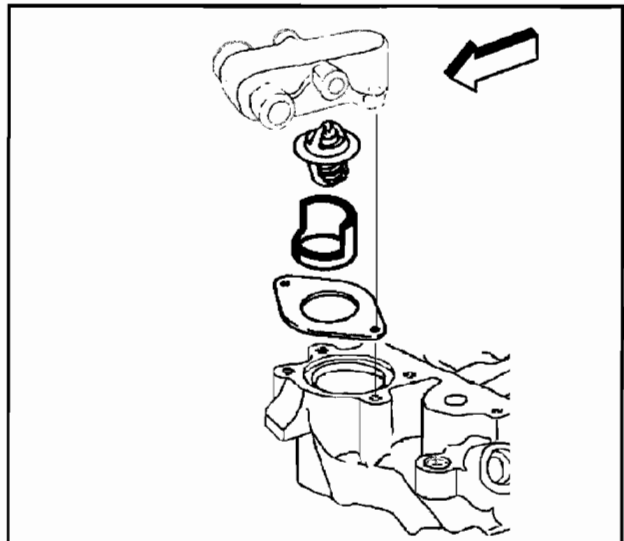
2. Remove the throttle body attaching studs.
3. Remove the throttle body.
4. Remove the throttle body to upper intake manifold gasket.
5. Discard the throttle body to upper intake manifold gasket.



500667

Engines equipped with Raw Water Cooling Systems

6. Remove the water Housing outlet studs.
7. Remove the water Housing outlet.
8. Remove the engine coolant thermostat.

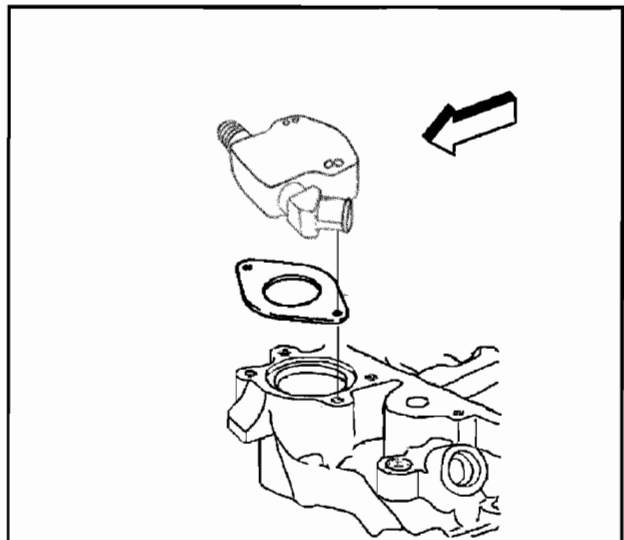


500671

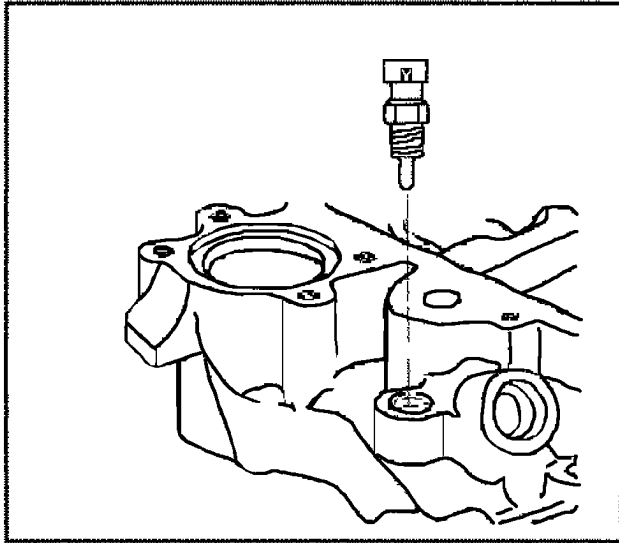
Engines equipped with Fresh Water Cooling Systems

6. Remove the water Housing outlet studs.
7. Remove the water Housing outlet.

Note: Engines equipped with fresh water cooling systems have thermostats in heat exchangers not outlet housing.

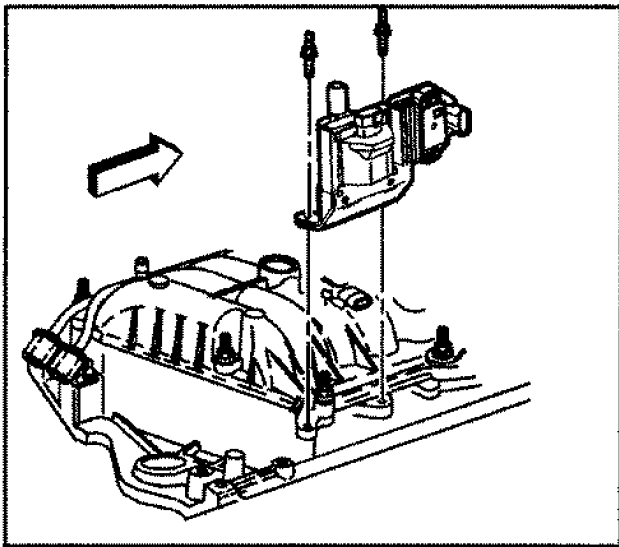


500671



10932

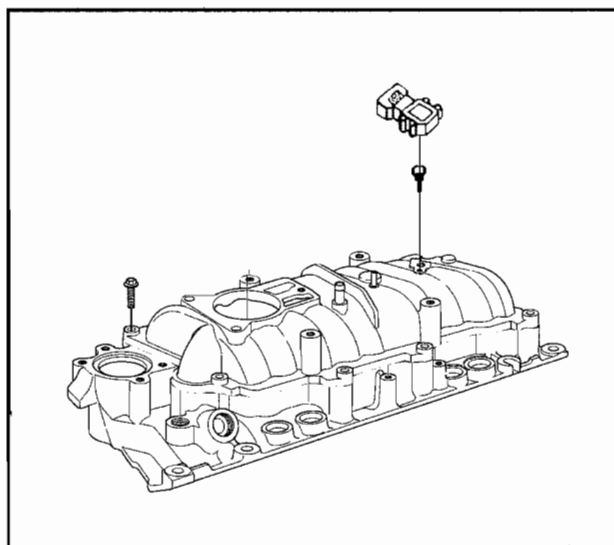
- 12. Remove the engine coolant temperature (ECT) sensor from the lower intake manifold.



500674

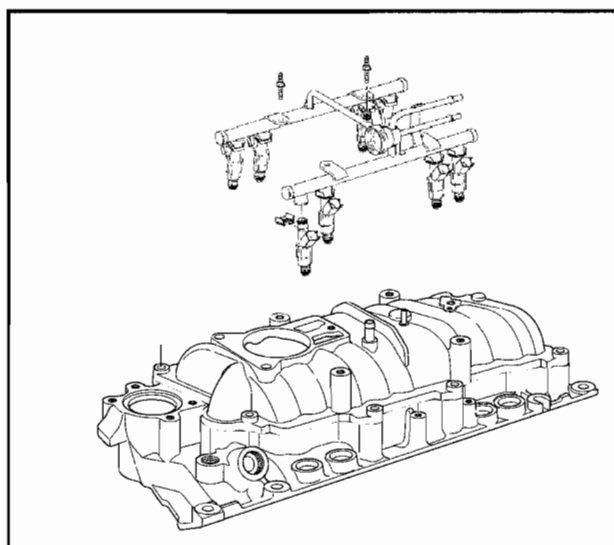
- 13. Remove the studs and the ignition coil.

14. Remove the manifold absolute pressure (MAP) sensor from the upper intake manifold.
15. Remove the MAP sensor seal from the MAP sensor.
16. Discard the MAP sensor seal.

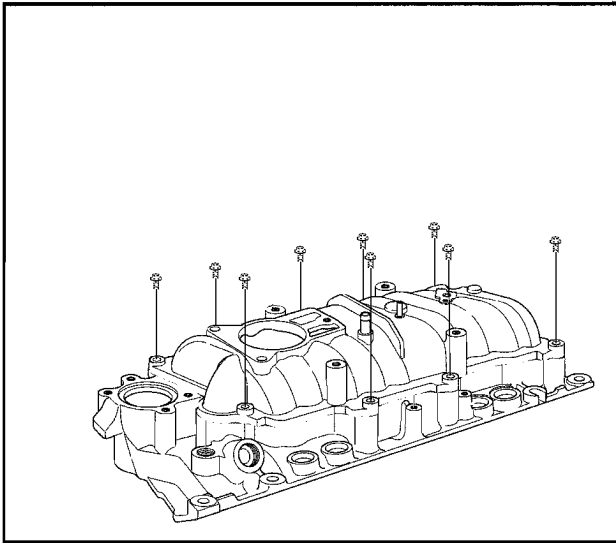


500677

17. Remove fuel injector rail assembly.
18. Remove the nut and the engine wiring harness bracket.

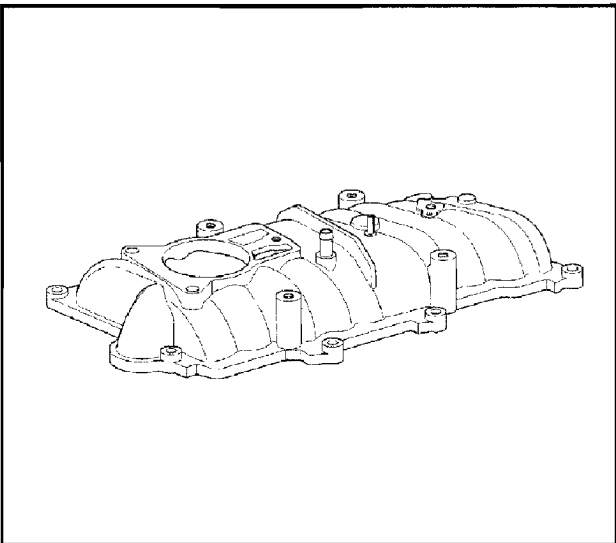


500679



500679

19. Remove the upper intake manifold studs
20. Remove the upper intake manifold
21. Remove the upper intake manifold to lower intake manifold gasket
22. Discard the upper intake manifold to lower intake manifold gasket



500679

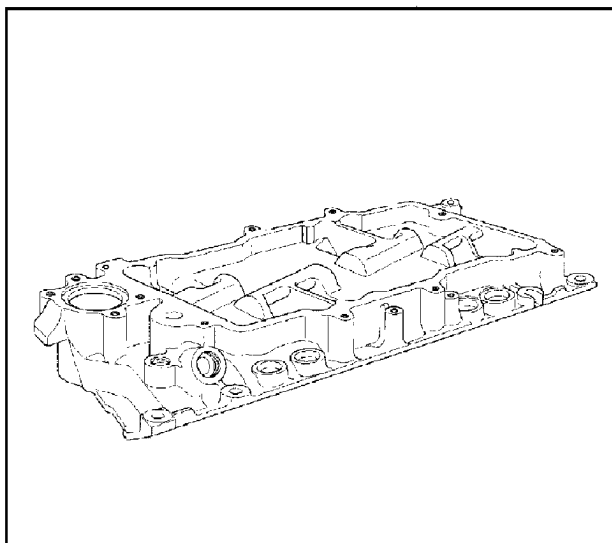
Intake Manifold Cleaning and Inspection

SIE-ID = 66845

Caution: Refer to Safety Glasses Caution in Cautions and Notices.

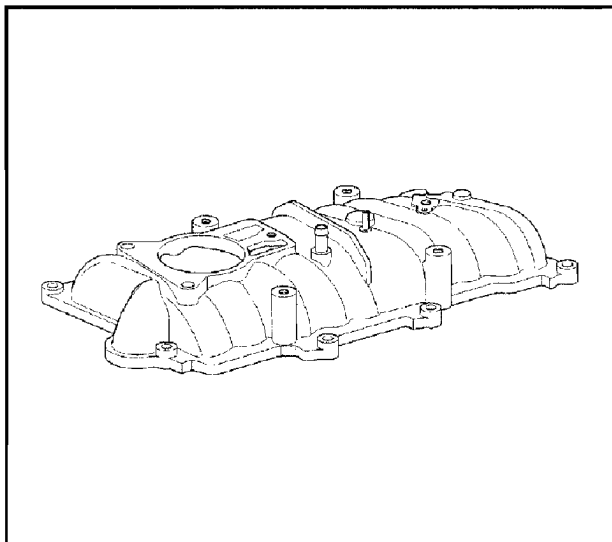
1. Clean the upper intake manifold in cleaning solvent.
2. Dry the upper intake manifold with compressed air.

3. Clean the lower intake manifold in cleaning solvent.
4. Dry the lower intake manifold with compressed air.



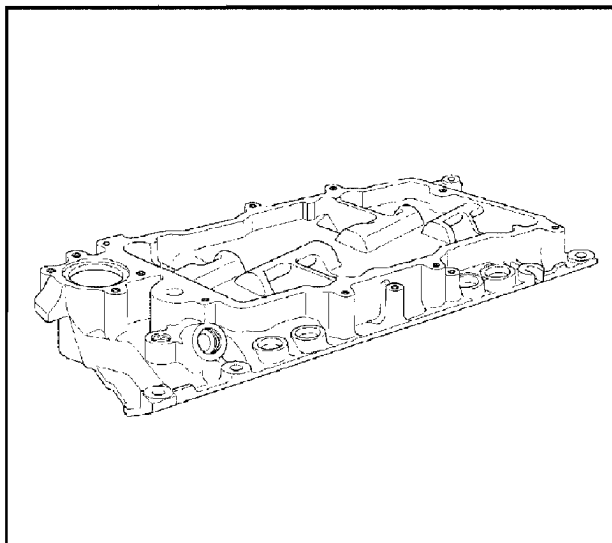
500684

5. Inspect the upper intake manifold for the following:
 - Cracks or other damage to the exterior
 - Cracking or damage in the gasket grooves
 - Damage to the throttle body mounting surface
 - Loose or damaged bolt hole thread inserts



500685

6. Inspect the lower intake manifold for the following:
 - Damage to the gasket sealing surfaces
 - Restricted cooling system passages
 - Cracks or damage
 - Damage to the threaded bolt holes



500686

Intake Manifold Assemble

SIE-ID = 194513

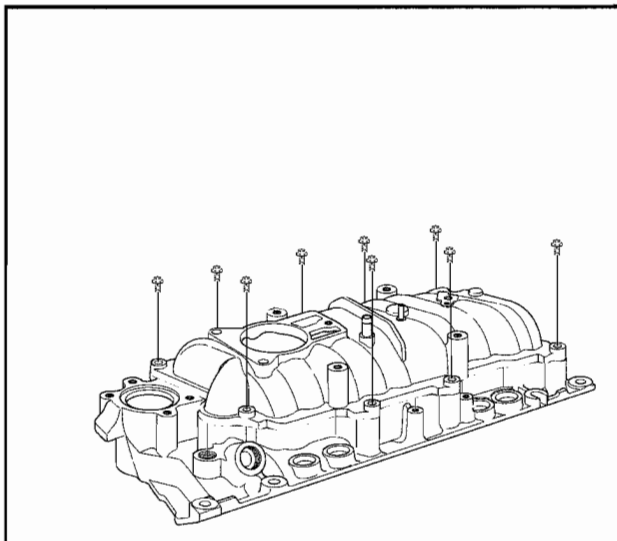
1. Install the upper intake manifold to lower intake manifold gasket into the groove of the upper intake manifold
2. Install the upper intake manifold onto the lower intake manifold
3. If reusing the fasteners, apply threadlock GM P/N United States 12345382, GM P/N Canada 10953489, or equivalent, to the threads of the upper intake manifold attaching studs

Notice: Refer to *Fastener Notice* in Cautions and Notices.

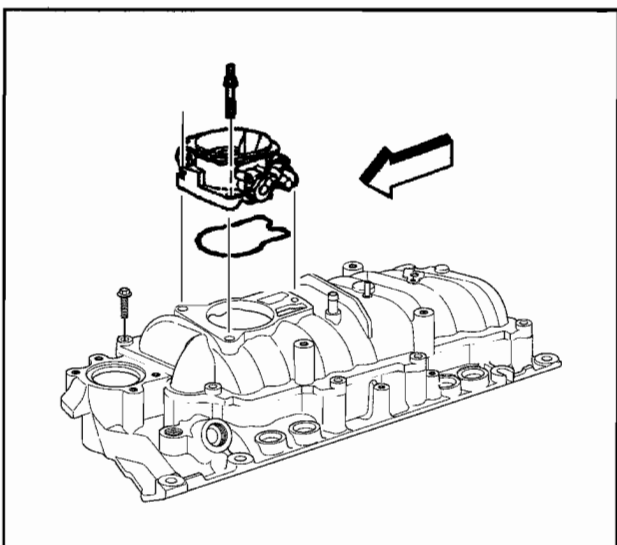
4. Install the upper intake manifold studs

Tighten

- 4.1. Tighten the upper intake manifold studs on the first pass to 5 N·m (44 lb in).
- 4.2. Tighten the upper intake manifold studs on the second pass to 10 N·m (89 lb in).



500679

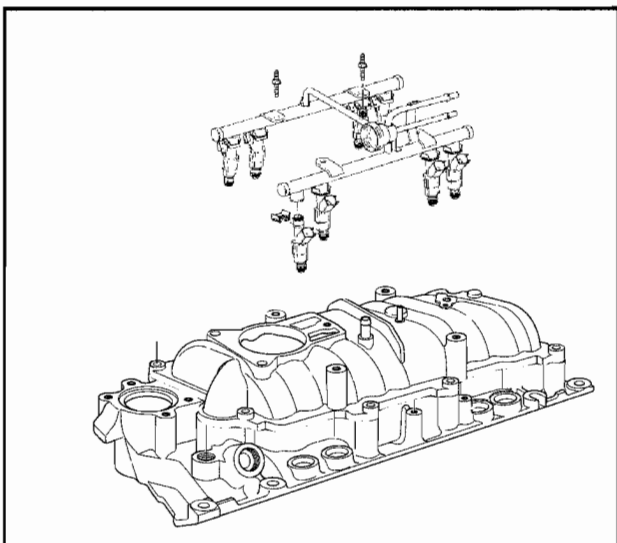


500667

5. Install a NEW throttle body gasket into the groove in the upper intake manifold.
6. Install the throttle body onto the upper intake manifold.
7. If reusing the fasteners, apply threadlock GM P/N United States 12345382, GM P/N Canada 10953489, or equivalent, to the threads of the throttle body attaching studs.
8. Install the throttle body attaching studs.

Tighten

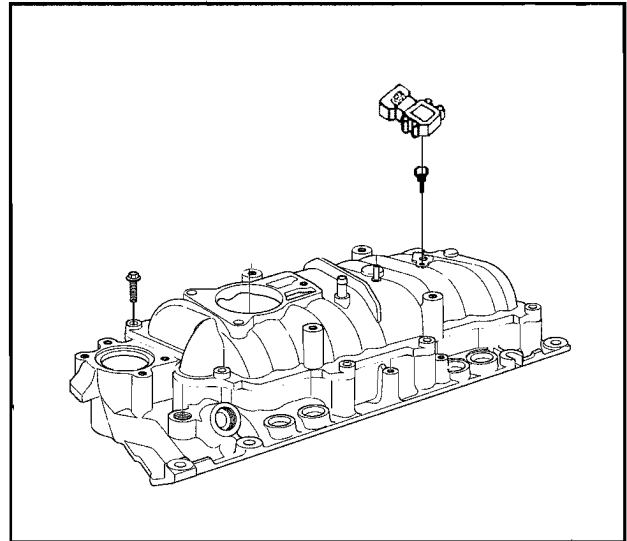
Tighten the throttle body attaching studs to 9 N·m (80 lb in).



500679

9. Install the fuel injector rail assembly.
10. Install the nut and the engine wiring harness bracket.

11. Install a NEW manifold absolute pressure (MAP) sensor seal onto the MAP sensor.
12. Apply a small amount, approximately 1 drop, of clean engine oil to the MAP sensor seal.
13. Install the MAP sensor into the upper intake manifold.

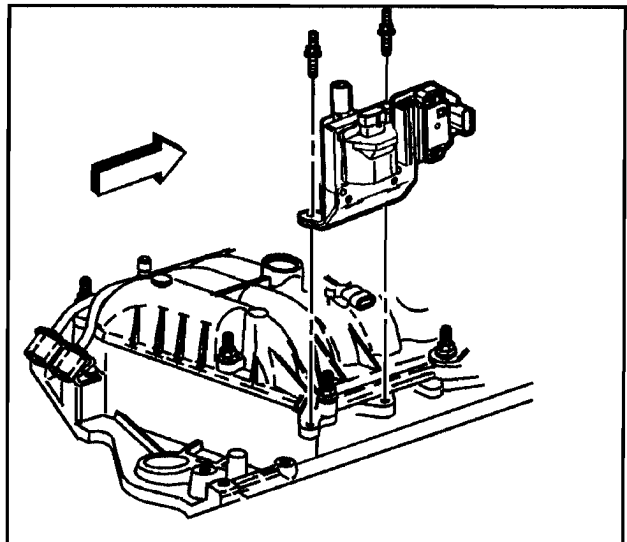


500677

14. Install the ignition coil and studs.

Tighten

Tighten the ignition coil studs to 12 N·m (106 lb in).

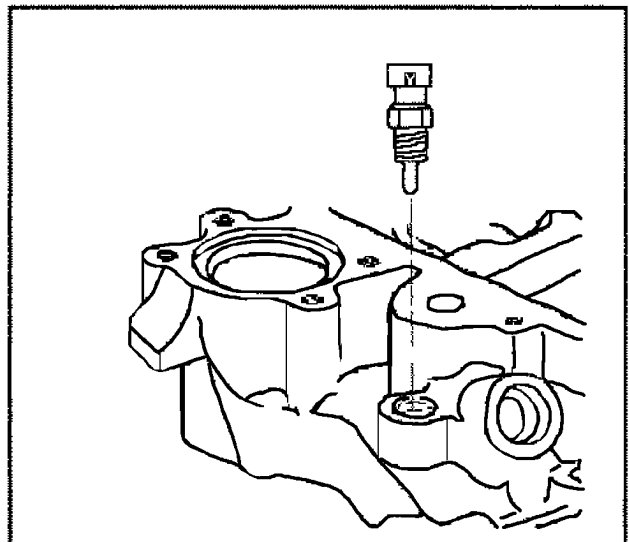


500674

15. If reusing the engine coolant temperature (ECT) sensor, apply sealant GM P/N United States 12346004, GM P/N Canada 10953480, or equivalent, to the threads of the ECT sensor.
16. Install the ECT sensor into the front of the lower intake manifold.

Tighten

Tighten the ECT sensor to 20 N·m (15 lb ft).



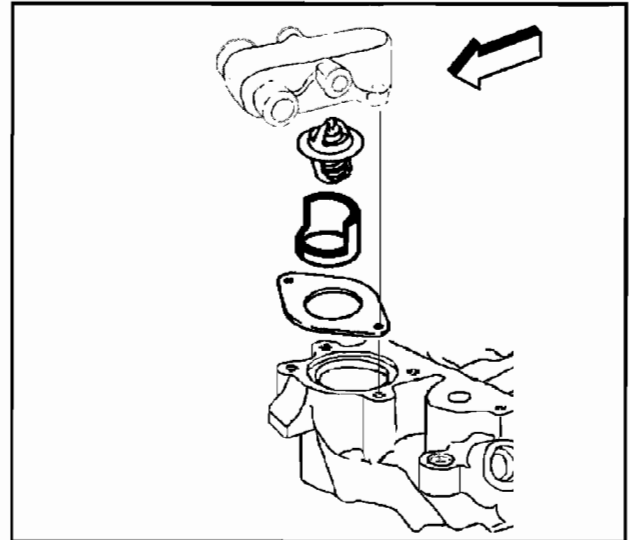
10932

Engines equipped with Raw Water Cooling Systems

17. Install the water Housing outlet studs.
18. Install the water Housing outlet.
19. Install the engine coolant thermostat.
20. Install the water outlet studs.

Tighten

Tighten the water outlet studs to 25 N·m (18 lb ft).

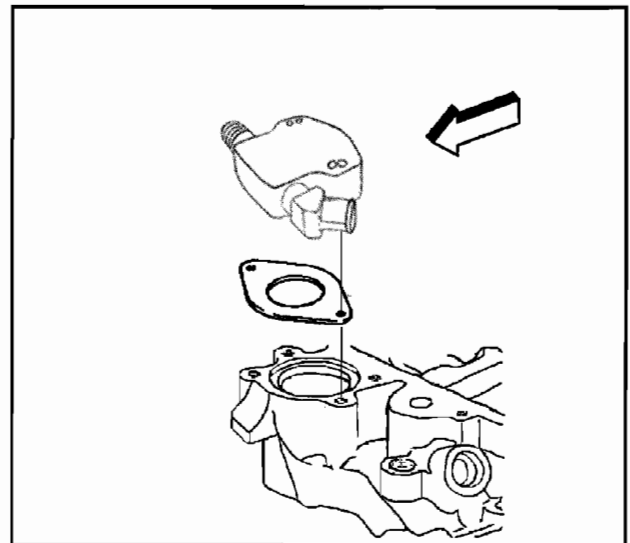


500671

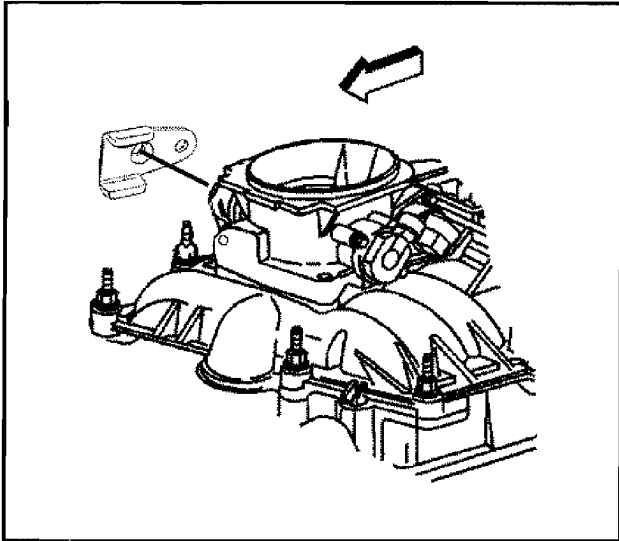
Engines equipped with Fresh Water Cooling Systems

21. Install the water Housing outlet studs.
22. Install the water Housing outlet.

Note: Engines equipped with fresh water cooling systems have thermostats in heat exchangers not outlet housing.

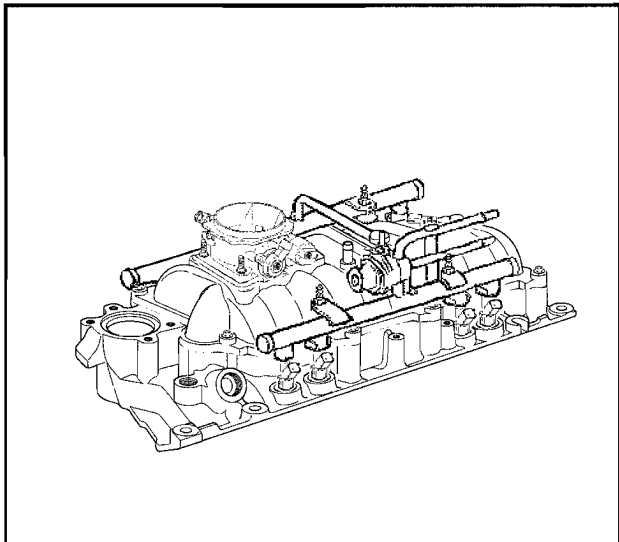


500671



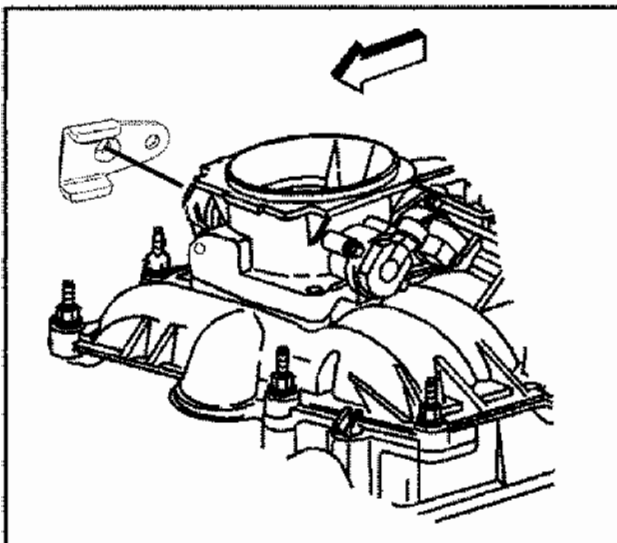
500661

23. Install the bolt and the Throttle Extension bracket.



500679

24. Complete Bosch IMF System (assembled)

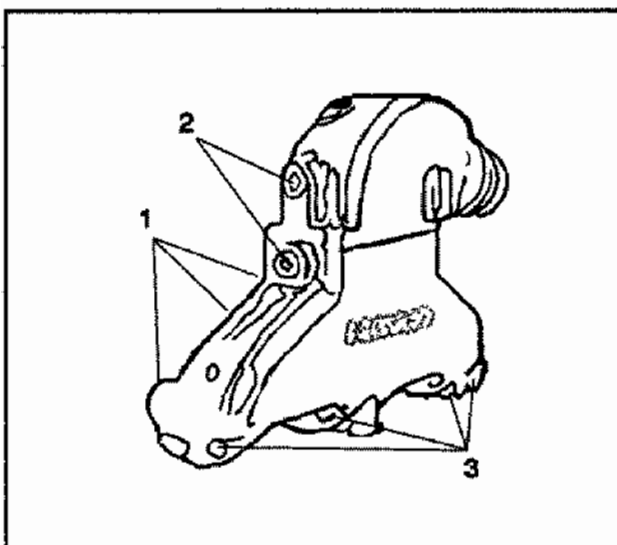


500661

35. Install the accelerator control bracket, the bolt, and the nut.

Tighten

Tighten the accelerator control bracket bolt and the nut to 12 N·m (106 lb in).



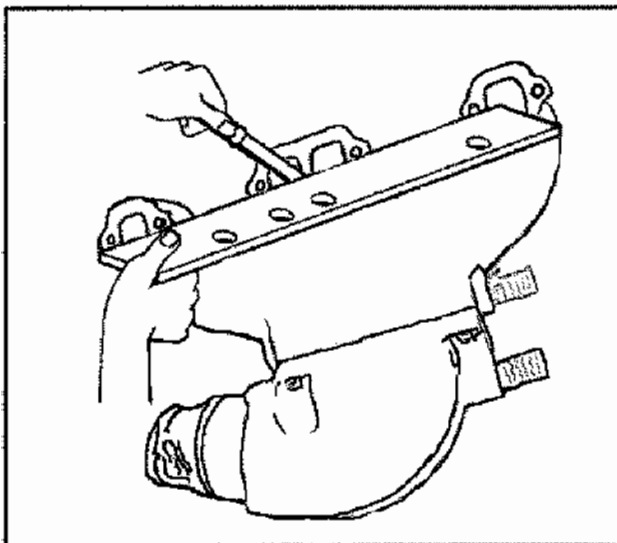
521830

Exhaust Manifold Cleaning and Inspection

SIE-ID = 784240

Caution: Refer to *Safety Glasses Caution in Cautions and Notices*.

1. Clean the exhaust manifolds in cleaning solvent.
2. Dry the components with compressed air.
3. Inspect the exhaust manifolds for the following:
 - Damage to the gasket sealing surfaces (1)
 - Damage to the exhaust gas recirculation (EGR) pipe fitting (2) (left manifold)
 - Damage to the take down bolt hole threads (3)
 - Restrictions within exhaust passages
 - Damaged or cracked exhaust manifold



86607

4. Measure the alignment or surface flatness of the exhaust manifold flanges, using a straight edge and a feeler gauge. Refer to *Engine Mechanical Specifications (5.0 L)* or *Engine Mechanical Specifications (5.7 L)*.

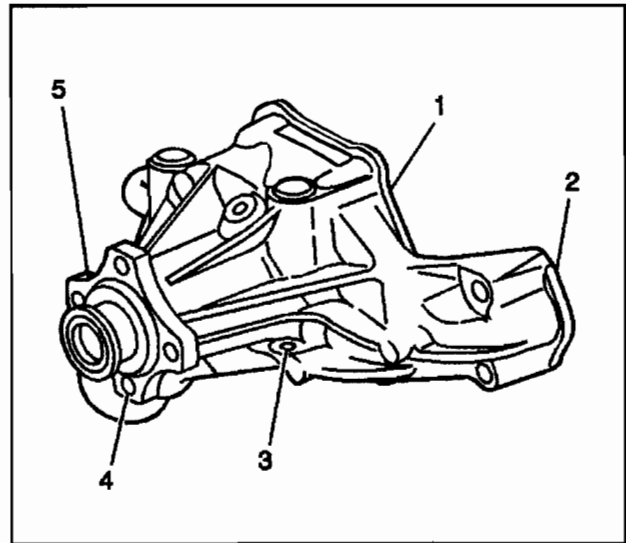
If the surface flatness is not within specifications, the exhaust manifold is warped and must be replaced.

Water Pump Cleaning and Inspection

SIE-ID = 194965

Caution: Refer to Safety Glasses Caution in Cautions and Notices.

1. Remove the old gasket material from the water pump sealing surfaces.
2. Clean all the dirt and any debris from the water pump.
3. Inspect the water pump for the following:
 - Leakage or damage to the housing cover or gasket (1)
 - Excessive scratches or gouging to the gasket sealing surfaces (2)
 - Leakage from the water pump vent hole (3)
A stain around the vent hole is acceptable. If leakage occurred (dripping) with the engine operating and the cooling system pressurized, then replace the water pump.
 - Damaged bolt hole threads (4)
 - Excessive side-to-side movement of the water pump shaft (5)
 - Restrictions within the internal coolant passages



480571

Thread Repair

SIE-ID = 43119

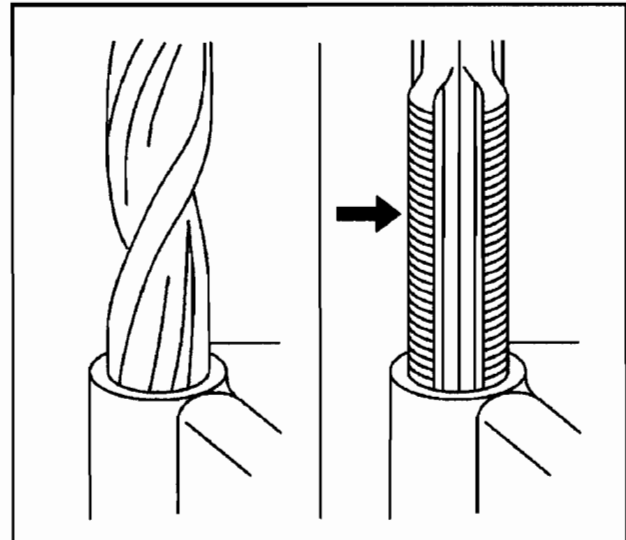
General purpose thread repair kits are available commercially.

Caution: Refer to Safety Glasses Caution in Cautions and Notices.

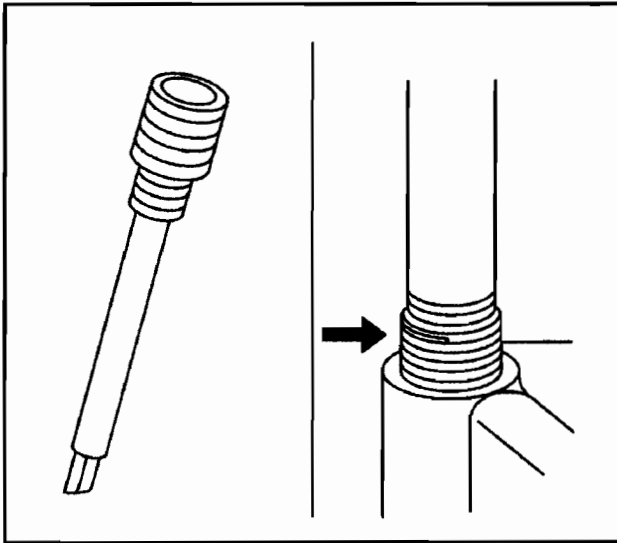
Important: Refer to the thread repair kit manufacturer's instructions regarding the size of the drill and which tap to use.

Always avoid any buildup of chips. Back out the tap every few turns and remove the chips.

1. Determine the size, the pitch, and the depth of the damaged thread.
2. Adjust the stop collars on the cutting tool as needed. Tap the stop collars to the required depth.
3. Drill out the damaged thread.
4. Remove the chips.
5. Apply clean engine oil to the top thread.
6. Use the tap in order to cut new thread.
7. Clean the thread.



4962



4963

8. Screw the thread insert onto the mandrel of the thread insert installer. Engage the tang of the thread insert onto the end of the mandrel.

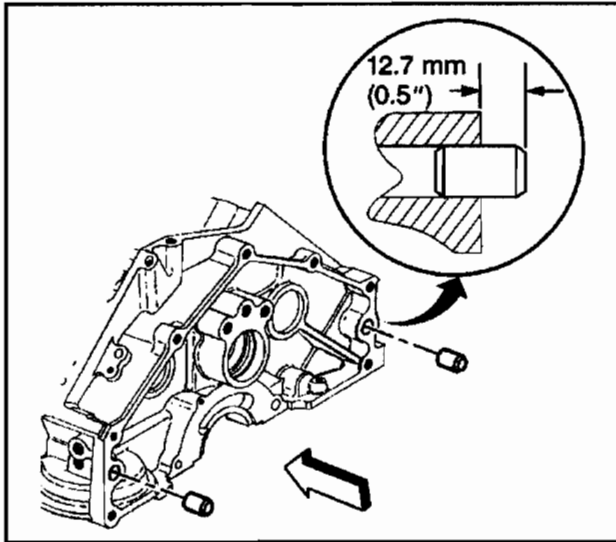
Important: The thread insert should be flush to 1 turn below the surface.

9. Lubricate the thread insert with clean engine oil (except when installing in aluminum) and install the thread insert.
10. If the tang of the thread insert does not break off when backing out the thread insert installer, break off the tang using a drift punch.

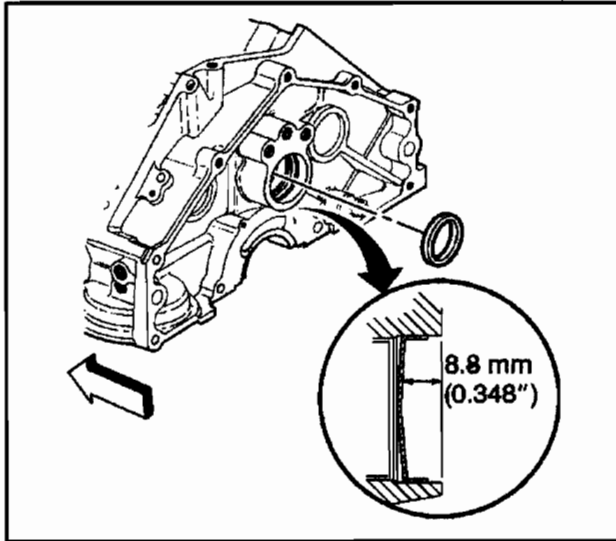
Service Prior to Assembly

SIE-ID = 43122

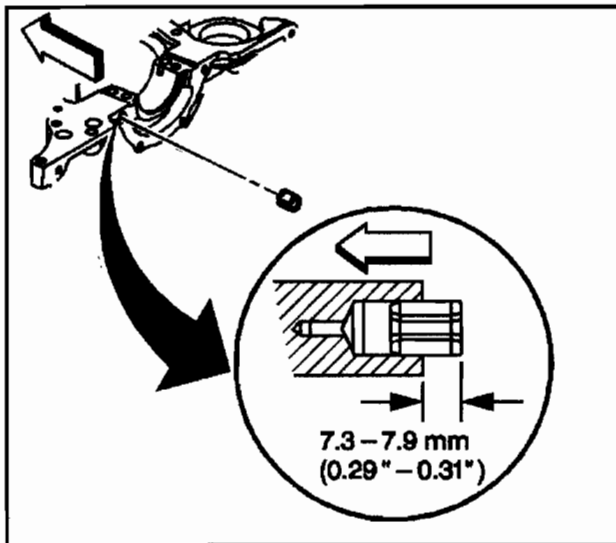
- Dirt will cause premature wear of the rebuilt engine. Clean all the components.
- Use the proper tools to measure the components when checking for excessive wear. Components not within the manufacturer's specification must be repaired or replaced.
- When the components are re-installed into an engine, return the components to the original location, position, and direction.
- During assembly, lubricate all the moving parts with clean engine oil (unless otherwise specified). The engine oil will provide the initial lubrication when the engine is first started.



182855



182854



521836

Engine Block Plug Installation

SIE-ID = 348917

Tools Required

J 41712 Oil Pressure Switch Socket

Caution: Refer to Safety Glasses Caution in Cautions and Notices.

1. Install the transmission locator pins, if required.
A properly installed transmission locator pin will protrude 12.7 mm (0.5 in) from the rear face of the engine block.
2. Apply sealant GM P/N United States 12346004, GM P/N Canada 10953480, or equivalent, to the outside diameter of the NEW camshaft rear bearing hole expansion cup plug.
3. Install the NEW camshaft rear bearing hole expansion cup plug.
4. Install the crankshaft rear oil seal housing locator S type pin.

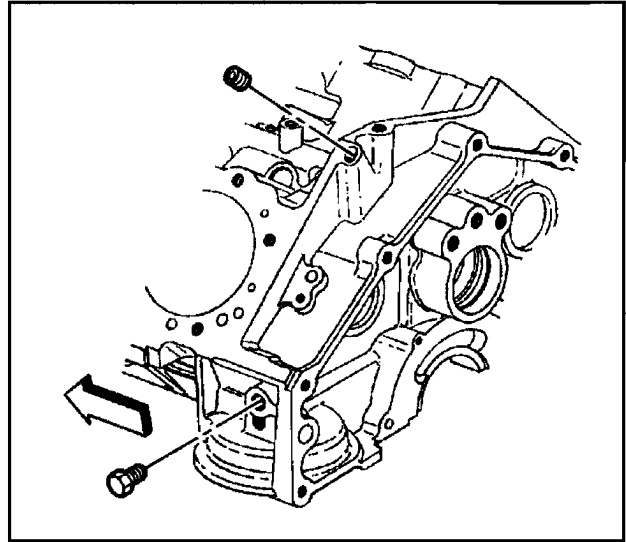
5. Apply sealant GM P/N United States 12346004, GM P/N Canada 10953480, or equivalent, to the threads of the left side rear and left rear top engine oil gallery plugs.

Notice: Refer to *Fastener Notice* in Cautions and Notices.

6. Install the left side rear and left rear top oil engine gallery plugs.

Tighten

Tighten the left side rear and left rear top engine oil gallery plugs to 20 N·m (15 lb ft).

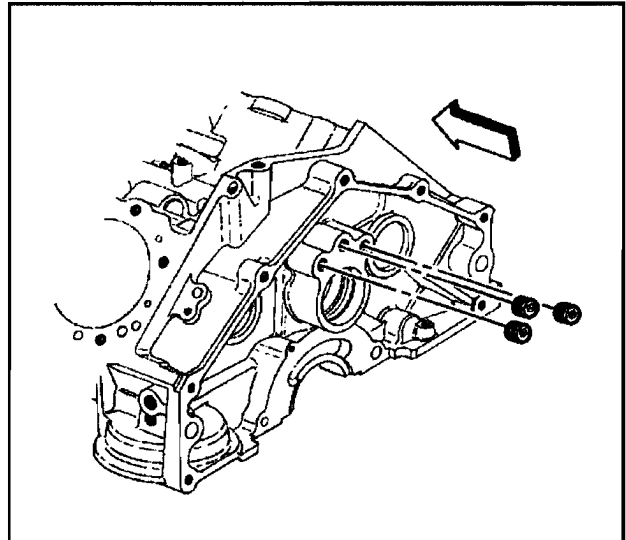


182841

7. Apply sealant GM P/N United States 12346004, GM P/N Canada 10953480, or equivalent, to the threads of the square socket engine block oil gallery plugs.
8. Install the square socket plugs.

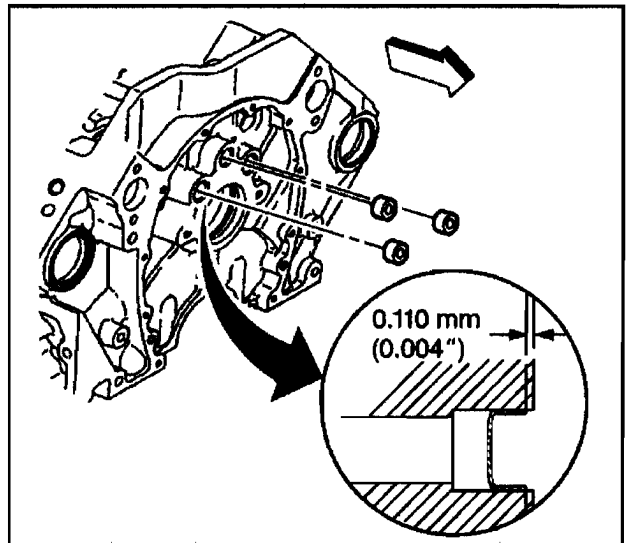
Tighten

Tighten the square socket plugs to 20 N·m (15 lb ft).

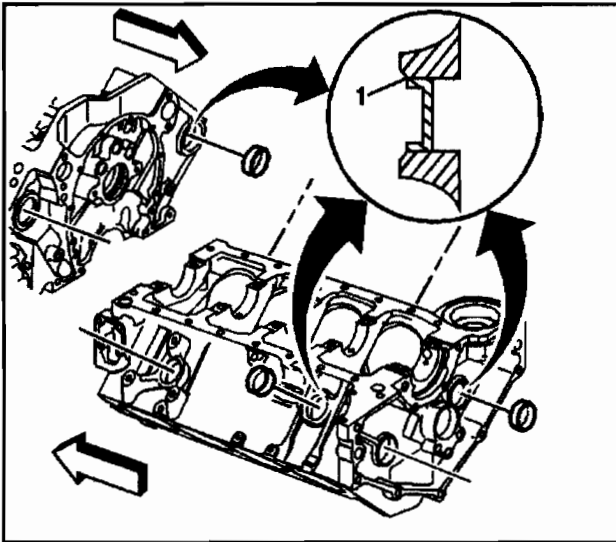


69847

9. Apply sealant GM P/N United States 12346004, GM P/N Canada 10953480, or equivalent to the outside diameter of the NEW engine oil gallery plugs.
10. Install the NEW engine block oil gallery plugs.
A properly installed engine oil gallery plug must be installed below flush with the front face of the engine block.

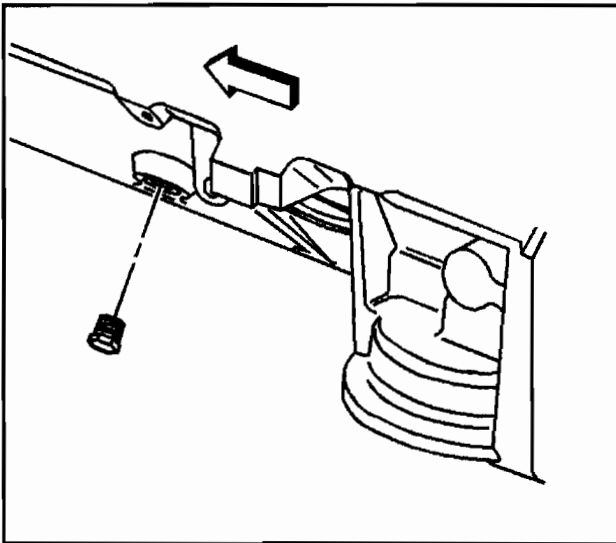


182838



500653

11. Apply threadlock GM P/N United States 12345382, GM P/N Canada 10953489, or equivalent, to the outside diameter of the NEW engine block core hole plugs.
12. Install the NEW engine block core hole plugs.
A properly installed engine block core hole plug must be installed flush or below the bottom of the chamfer (1) of the engine block core hole.



316798

13. Apply sealant GM P/N United States 12346004, GM P/N Canada 10953480, or equivalent, to the threads of the engine block coolant drain hole plug.
14. Install the engine block coolant drain hole plug.

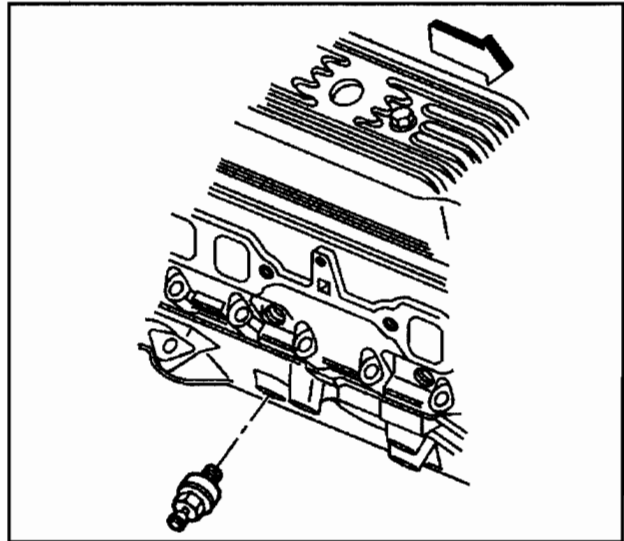
Tighten

Tighten the engine block coolant drain hole plug to 20 N·m (15 lb ft).

20. Apply sealant GM P/N United States 12346004, GM P/N Canada 10953480, or equivalent, to the threads of the knock sensor.
21. Install the knock sensor.

Tighten

Tighten the knock sensor to 19 N·m (14 lb ft).



182837

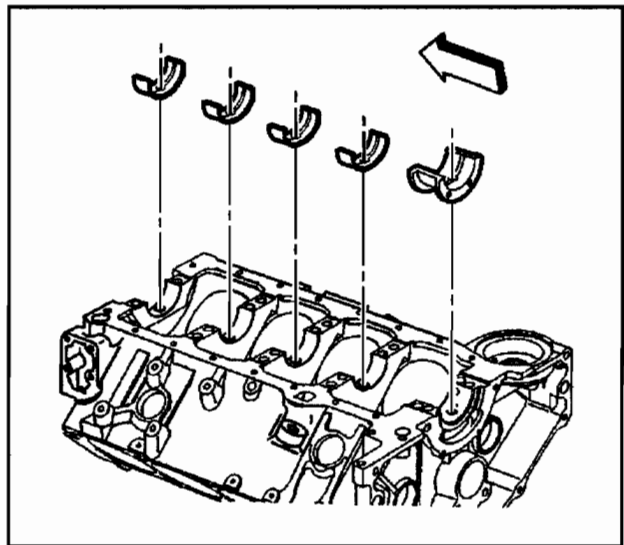
Crankshaft and Bearings Installation

SIE-ID = 66853

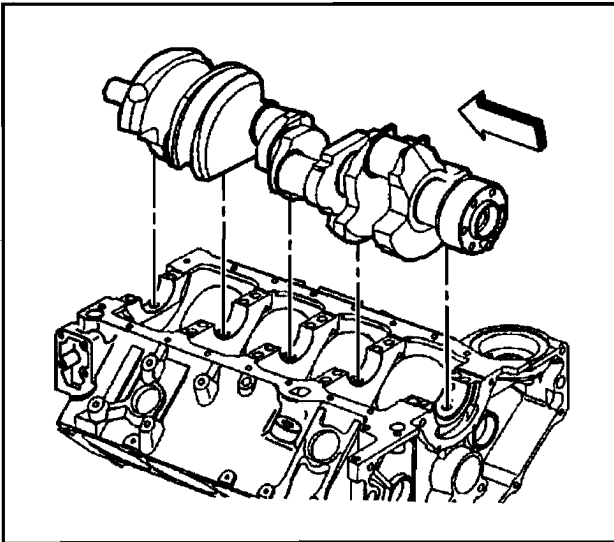
Tools Required

J 36660-A Electronic Torque Angle Meter

1. Install the crankshaft bearings into the engine block.
2. Apply clean engine oil to the crankshaft bearings.

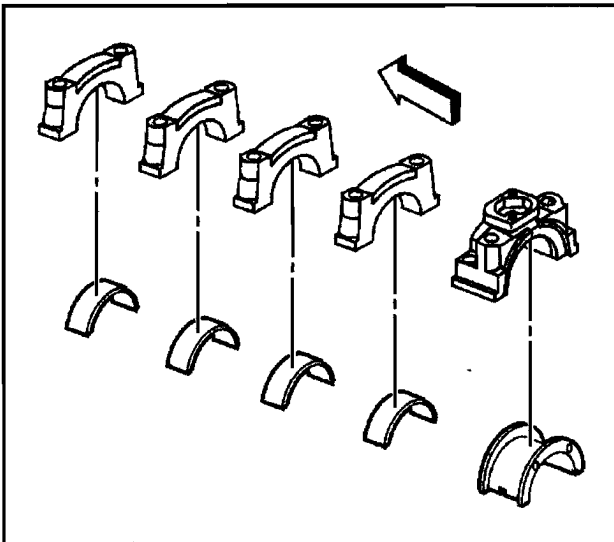


317292



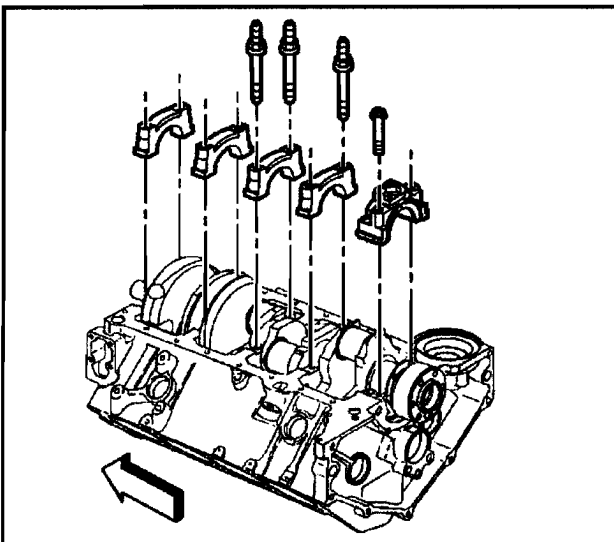
317351

3. Apply clean engine oil to the crankshaft bearing journals.
4. Install the crankshaft.



317295

5. Install the crankshaft bearings into the crankshaft bearing caps.
6. Apply clean engine oil to the crankshaft bearings.



317268

Important: Ensure that the crankshaft bearing cap directional arrow points toward the front of the engine block, and the crankshaft bearing cap is in the original location and position.

7. Install the crankshaft bearing caps in the original positions and with the arrow on the crankshaft bearing caps in the direction of the front of the engine block.
8. Install the crankshaft bearing cap bolts and the crankshaft bearing cap studs.
9. Thrust the crankshaft rearward in order to set and align the crankshaft thrust bearings and the crankshaft bearing caps.
10. Thrust the crankshaft forward in order to align the rear faces of the crankshaft thrust bearings.

11. Ensure that the crankshaft bearing caps are fully seated in the engine block crankshaft bearing cap channel, and that the crankshaft bearing caps are centered on the engine block bulkheads.
12. Measure the crankshaft end play.
 - 12.1. Tighten the crankshaft bearing cap bolts and the crankshaft bearing cap studs finger tight.
 - 12.2. Firmly thrust the crankshaft rearward, and then forward.
This will align the crankshaft rear bearing thrust surfaces.
 - 12.3. With the crankshaft pushed forward, insert a feeler gauge between the crankshaft and the crankshaft rear bearing thrust surface to measure the clearance.

Specification

Crankshaft end play 0.05–0.20 mm (0.002–0.008 in)

Notice: Refer to *Fastener Notice* in Cautions and Notices.

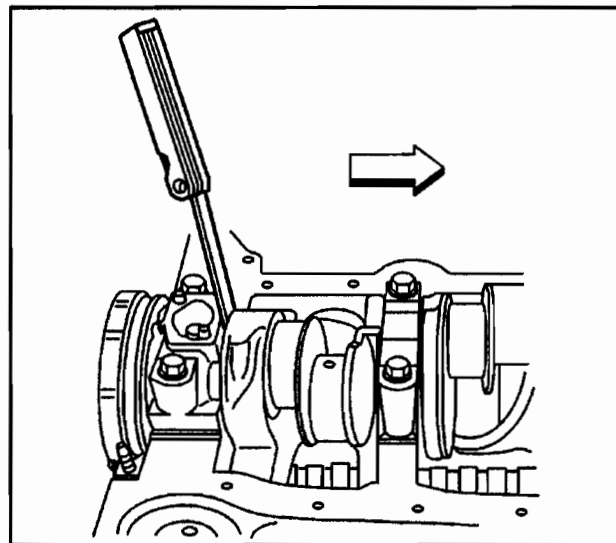
13. Tighten the crankshaft bearing cap bolts and the crankshaft bearing cap studs.

Tighten

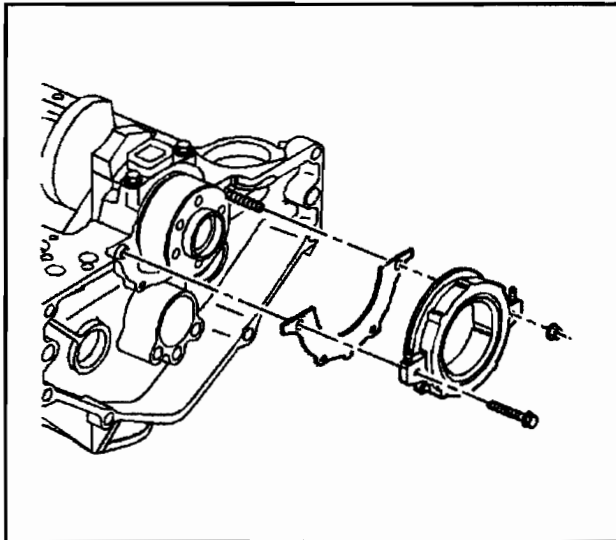
- 13.1. Tighten the crankshaft bearing cap bolts and the crankshaft bearing cap studs on the first pass to 20 N·m (15 lb ft).
 - 13.2. Tighten the crankshaft bearing cap bolts and the crankshaft bearing cap studs (2 bolt caps) on the final pass to 73 degrees using the *J 36660-A*.
 - 13.3. Tighten the bearing cap outboard bolts (4 bolt caps) on the final pass to 43 degrees using the *J 36660-A*.
 - 13.4. Tighten the bearing cap inboard bolts and the bearing cap inboard studs (4 bolt caps) on the final pass to 73 degrees using the *J 36660-A*.
14. Rotate the crankshaft in order to check for binding.
A bent crankshaft, or lack of proper crankshaft bearing clearance, may cause binding.
 15. If the crankshaft does not turn freely, loosen the crankshaft bearing cap bolts on 1 crankshaft bearing cap at a time in order to determine the location of the binding.

A lack of proper crankshaft bearing clearance may be caused by the following:

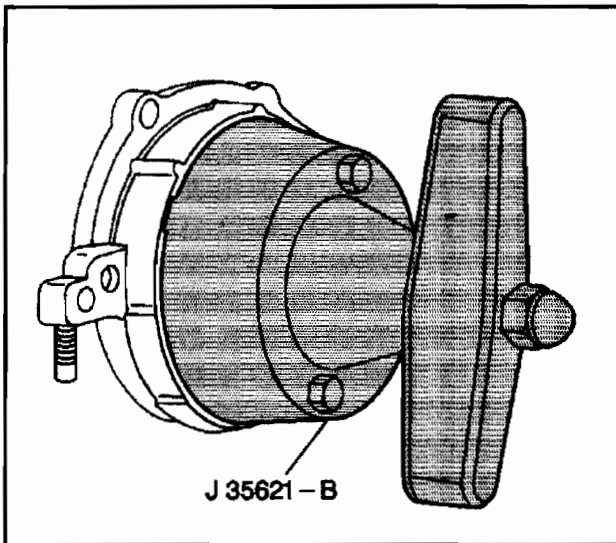
- Burrs on the crankshaft bearing cap
- Foreign material between the crankshaft bearing and the engine block
- Foreign material between the crankshaft bearing and the crankshaft bearing cap
- Damaged crankshaft bearing
- Improper size crankshaft bearing



188467



11479



334550

Crankshaft Rear Oil Seal and Housing Installation

SIE-ID = 348923

Tools Required

J 35621-B Rear Main Seal Installer

Notice: Refer to *Fastener Notice* in Cautions and Notices.

1. Install the crankshaft rear oil seal housing retainer stud.

Tighten

Tighten the crankshaft rear oil seal housing retainer stud to 6 N·m (53 lb in).

Important: Always use a NEW crankshaft rear oil seal housing gasket when installing the crankshaft rear oil seal housing.

2. Install the NEW crankshaft rear oil seal housing gasket and the crankshaft rear oil housing onto the crankshaft rear oil seal housing retainer stud.
3. Install the crankshaft rear oil seal housing nut and bolts.

Tighten

Tighten the crankshaft rear oil seal housing nut and bolts to 12 N·m (106 lb in).

4. Apply a small amount, approximately 2–3 drops, of clean engine GM P/N United States 12345610, GM P/N Canada 993193, or equivalent, oil to the bore of the crankshaft rear oil seal housing.
5. Inspect the outside diameter of the engine flywheel pilot flange for imperfections or rust.
Minor imperfections and/or rust may be removed with a fine grade emery cloth.
6. Apply a small amount, approximately 2–3 drops, of clean engine GM P/N United States 12345610, GM P/N Canada 993193, or equivalent, oil to the outside diameter of the engine flywheel pilot flange.
7. Apply a small amount, approximately 1 drop, of clean engine oil GM P/N United States 12345610, GM P/N Canada 993193, or equivalent, to the outside diameter of the flywheel locator pin.
8. Apply a small amount of clean engine GM P/N United States 12345610, GM P/N Canada 993193, or equivalent, oil to the crankshaft seal surface.
9. Inspect the J 35621-B flange for imperfections that may damage the crankshaft rear oil seal.
Minor imperfections may be removed with a fine grade emery cloth.

Important: DO NOT allow oil or any other lubricants to contact the seal lip surface of the crankshaft rear oil seal.

10. Remove the installation guide from the NEW crankshaft rear oil seal.

11. Apply a small amount, approximately 2–3 drops, of clean engine oil GM P/N United States 12345610, GM P/N Canada 993193, or equivalent, to the outside diameter of the NEW crankshaft rear oil seal.
12. Install the NEW crankshaft rear oil seal onto the *J 35621-B*.
13. Install the *J 35621-B* onto the rear of the crankshaft and hand tighten the tool bolts until snug.

Notice: SIO-ID = 348112 Proper alignment of the crankshaft rear oil seal is critical. Install the crankshaft rear oil seal near to flush and square to the crankshaft rear oil seal housing. Failing to do so may cause the crankshaft rear oil seal or the crankshaft rear oil seal installation tool to fail.

Important: A properly installed crankshaft rear oil seal will be near to flush and square to the crankshaft rear oil seal housing.

14. Install the crankshaft rear oil seal onto the crankshaft and into the crankshaft rear oil seal housing.
 - 14.1. Turn the *J 35621-B* wing nut clockwise until the crankshaft rear oil seal is installed near to flush and square to the crankshaft rear oil seal housing.
Increased resistance will be felt when the crankshaft rear oil seal has reached the bottom of the crankshaft rear oil seal housing bore.
 - 14.2. Turn the *J 35621-B* wing nut counter clockwise to release the *J 35621-B* from the crankshaft rear oil seal. -
15. Remove the *J 35621-B* from the crankshaft.
16. Wipe off any excess engine oil with a clean rag.

Piston, Connecting Rod, and Bearing Installation

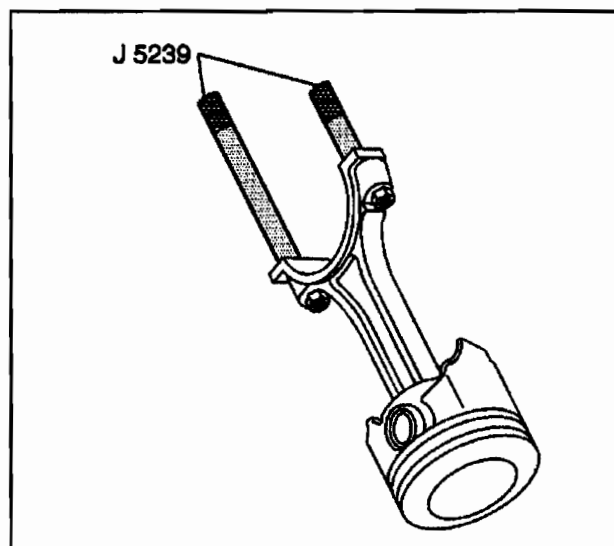
SIE-ID = 650066

Tools Required

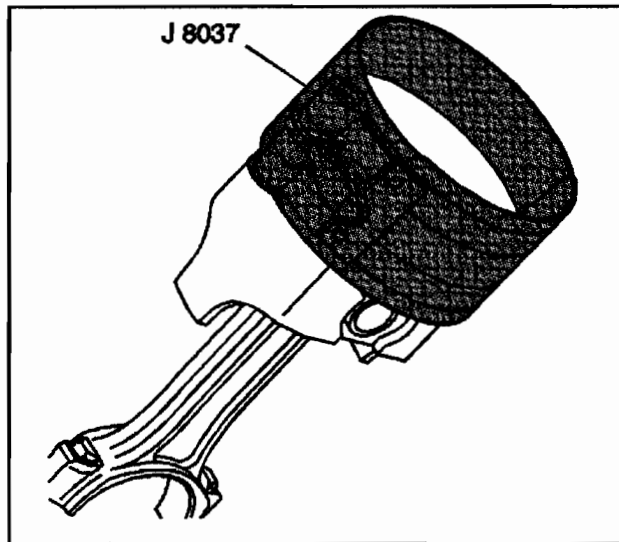
- *J 5239* Connecting Rod Bolt Guide Set
- *J 8037* Ring Compressor
- *J 36660-A* Torque Angle Meter

Important: The piston and cylinder bore have been measured and the bore has been sized for the proper clearance. Install the piston and connecting rod assembly into the proper cylinder bore. The piston alignment mark **MUST** face the front of the engine block.

1. Apply clean engine oil to the following components:
 - The piston
 - The piston rings
 - The cylinder bore
 - The connecting rod bearing surfaces
2. Install the *J 5239* onto the connecting rod bolts.

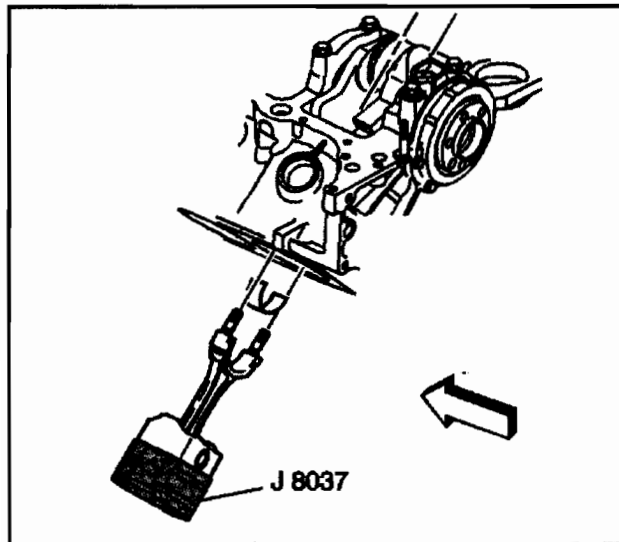


387765



480573

3. Install the *J 8037* onto the piston and compress the piston rings.

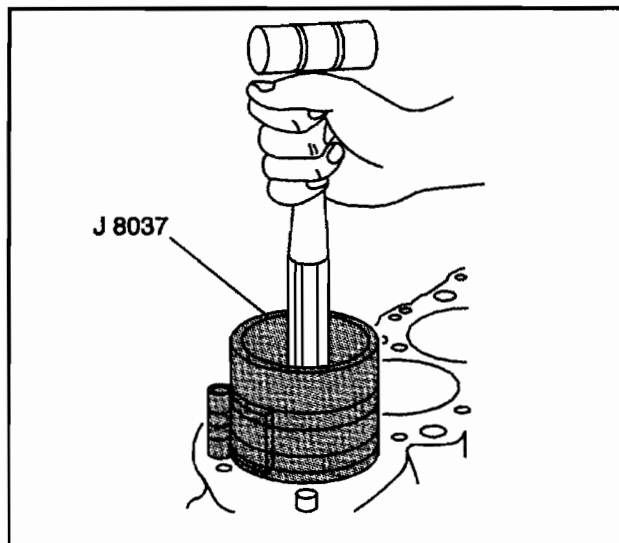


492144

Important: The mark on the top of the piston must face the front of the engine block.

When assembled, the flanges on the connecting rod and connecting rod cap should point to the front of the engine block on the left bank and point to the rear of the engine block on the right bank.

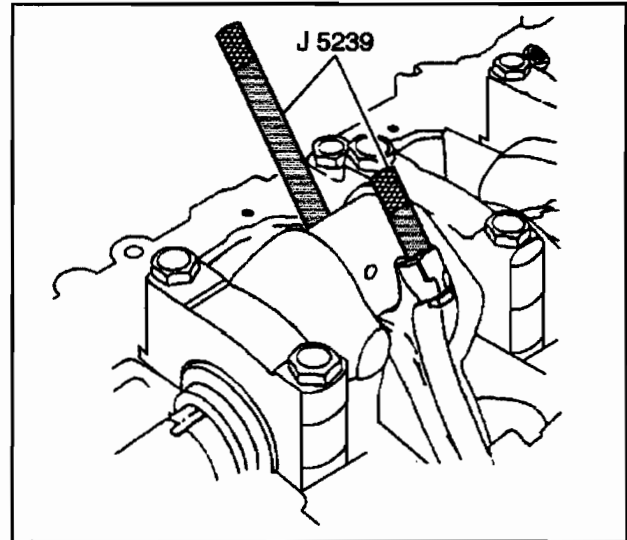
4. Install the connecting rod bearing.
5. Install the piston and connecting rod assembly, and the *J 8037* into the proper cylinder bore.



5159

6. Use the *J 8037* and the *J 5239* and lightly tap the top of the piston with a wooden hammer handle.
 - 6.1. Hold the *J 8037* firmly against the engine block until all of the piston rings have entered the cylinder bore.
 - 6.2. Use the *J 5239* in order to guide the connecting rod onto the crankshaft journal.

7. Remove the *J 5239* from the connecting rod bolts.



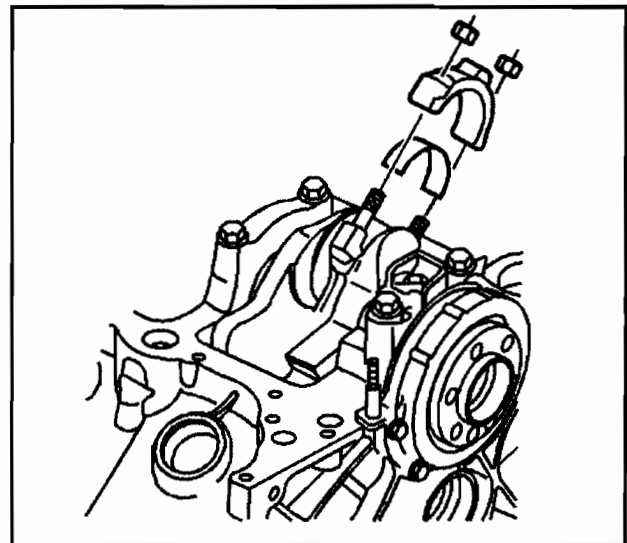
31373

Notice: Refer to *Fastener Notice* in Cautions and Notices.

8. Install the connecting rod bearing, cap, and nuts.

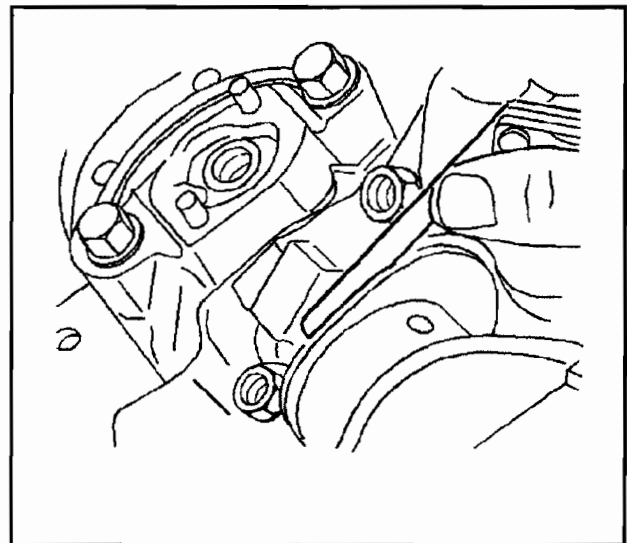
Tighten

- 8.1. Tighten the nuts on the first pass evenly to 27 N·m (20 lb ft).
- 8.2. Tighten the nuts on the final pass to 55 degrees using the *J 36660-A*.

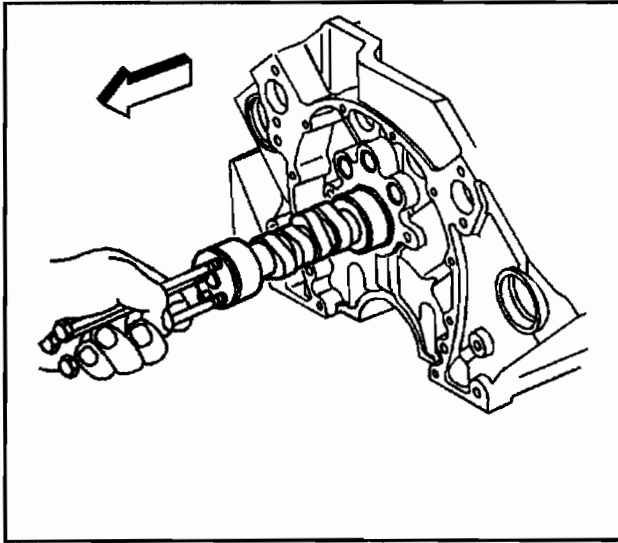


480549

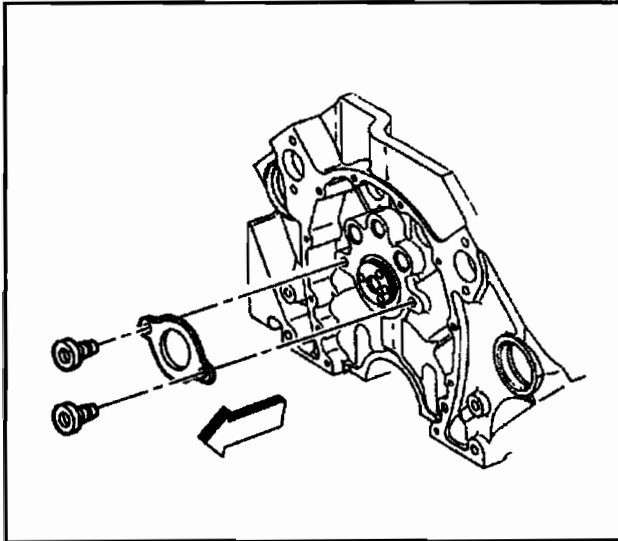
9. Once the piston and connecting rod assemblies have been installed, lightly tap each connecting rod assembly, parallel to the crankpin, in order to make sure that the connecting rods have the proper side clearance.
10. Use a feeler gage or a dial indicator to measure the side clearance between the connecting rod caps. The connecting rod side clearance measurement should be 0.15–0.68 mm (0.006–0.027 in).



5163



69013



182836

Camshaft Installation

SIE-ID = 66855

Notice: SIO-ID = 13833 All camshaft journals are the same diameter, so care must be used in removing or installing the camshaft to avoid damage to the camshaft bearings.

1. Lubricate the following components with clean engine oil GM P/N United States 12345610, GM P/N Canada 993193, or equivalent, or engine oil supplement GM P/N United States 1052367, GM P/N Canada 992367, or equivalent:
 - The engine camshaft lobes
 - The camshaft bearing journals
 - The camshaft bearings
 - The distributor drive gear
2. Install the 3 5/16-18 x 4.0 inch bolts in the engine camshaft bolt holes.
3. Install the engine camshaft using the bolts as a handle.
4. Remove the 3 bolts from the engine camshaft.

Notice: Refer to *Fastener Notice* in Cautions and Notices.

5. Install the camshaft retainer and bolts.

Tighten

Tighten the camshaft retainer bolts to 12 N·m (106 lb in).

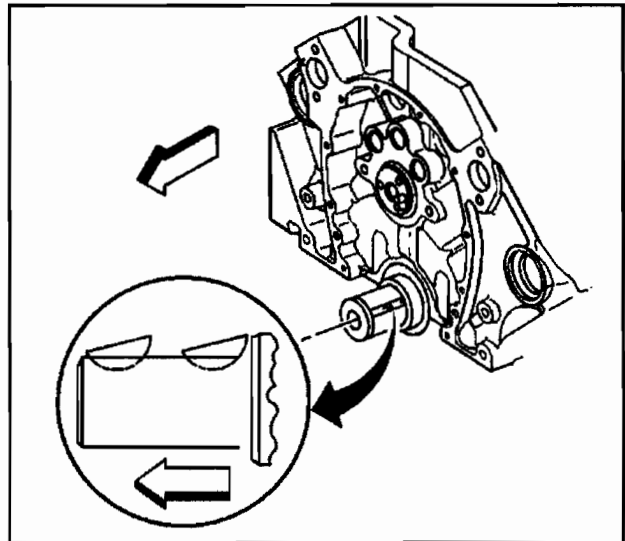
Timing Chain and Sprockets Installation

SIE-ID = 69464

Tools Required

J 5590 Installer

1. Install the crankshaft balancer woodruff keys into the crankshaft keyway.

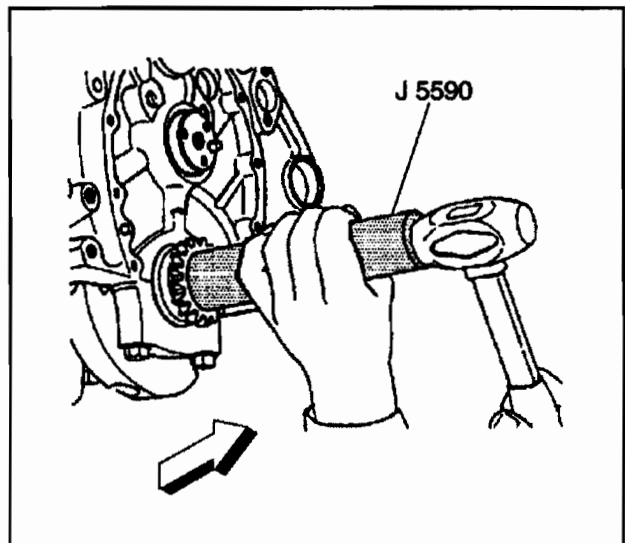


182847

2. Align the keyway of the crankshaft sprocket with the crankshaft balancer woodruff key.

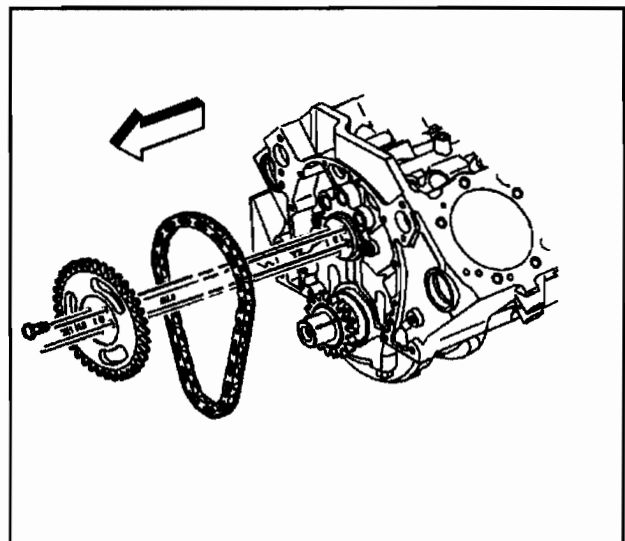
Caution: Refer to Safety Glasses Caution in Cautions and Notices.

3. Use the *J 5590* in order to install the crankshaft sprocket.
4. Rotate the crankshaft until the crankshaft sprocket alignment mark is in the 12 o'clock position.

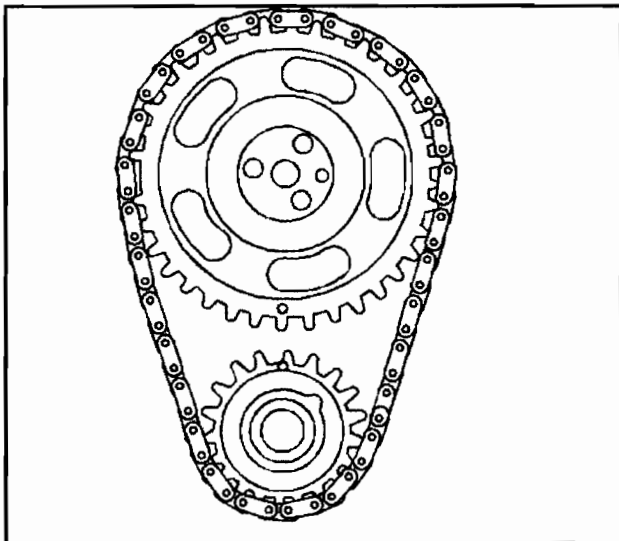


32066

5. Install the camshaft sprocket and the camshaft timing chain. Install the camshaft sprocket with the alignment mark in the 6 o'clock position.



500645



11503

Notice: S10-ID = 788777 Do not use tools to force the camshaft sprocket onto the camshaft. The camshaft sprocket is a slip fit onto the camshaft and does not require tools to install. Using force against the camshaft can cause component damage and cause the expansion plug at the rear of the block to move out of position. The expansion plug out of position can leak engine oil or fall out. A missing or leaking expansion plug at the rear of the camshaft bearings can cause a loss of oil and oil pressure leading to extensive engine damage.

6. Rotate the camshaft until the camshaft and crankshaft sprocket alignment marks are in the proper position.

Notice: Refer to *Fastener Notice* in Cautions and Notices.

7. Install camshaft sprocket bolts.

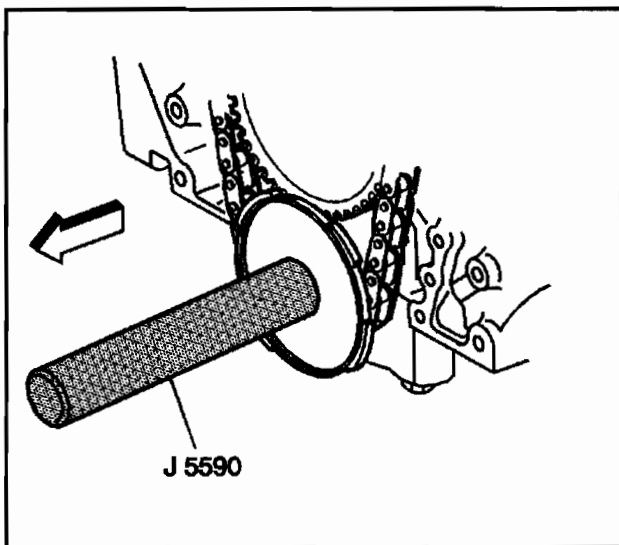
Tighten

Tighten the camshaft sprocket bolts to 25 N·m (18 lb ft).

Important: Align the keyway on the crankshaft position sensor reluctor ring with the crankshaft balancer woodruff key in the crankshaft. Install the crankshaft position sensor reluctor ring onto the crankshaft until completely seated against the crankshaft sprocket.

8. Install the crankshaft position sensor reluctor ring.

- 8.1. Align the keyway on the crankshaft position sensor reluctor ring with the crankshaft balancer woodruff key in the crankshaft.
- 8.2. Use the *J 5590* in order to push the crankshaft position sensor reluctor ring onto the crankshaft until completely seated against the crankshaft sprocket.



521825

Engine Front Cover Installation

SIE-ID = 194773

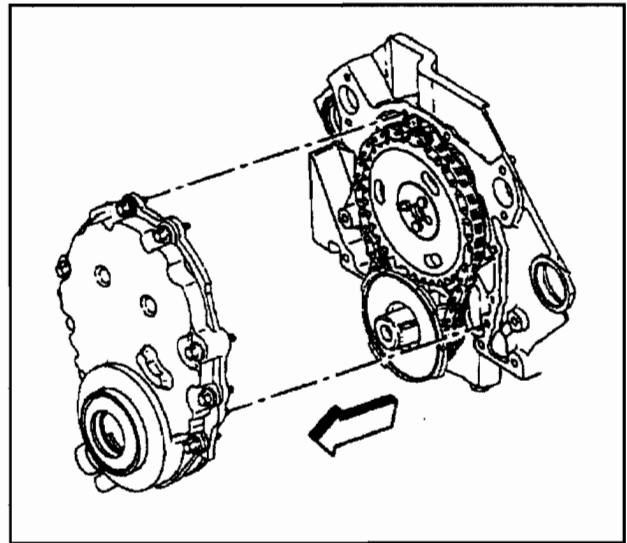
Notice: Refer to *Fastener Notice* in Cautions and Notices.

Important: Do not reuse the composite type engine front cover and seal. Always install a NEW engine cover, which includes a new seal.

1. Install the NEW engine front cover and bolts.

Tighten

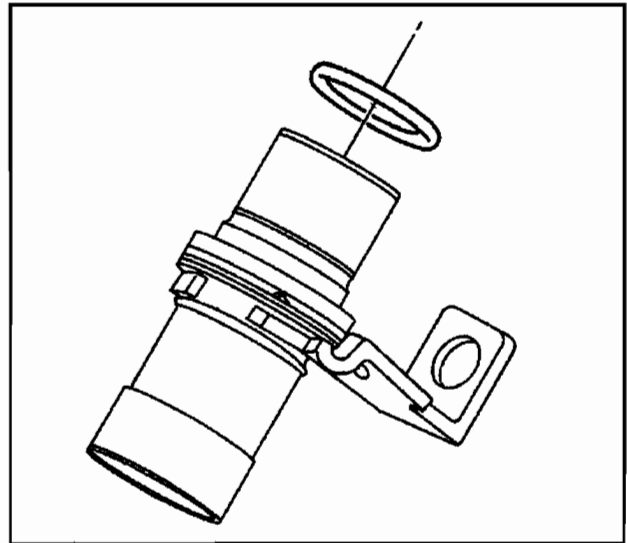
Tighten the engine front cover bolts to 12 N·m (106 lb in).



69010

Important: DO NOT reuse the original crankshaft position sensor seal, O-ring. When installing the crankshaft position sensor be sure the crankshaft position sensor is fully seated and held stationary in the engine front cover crankshaft position sensor bore. A crankshaft position sensor that is not completely seated will cock in the engine front cover and may result in erratic engine operation.

2. Lubricate the NEW crankshaft position sensor seal, O-ring, with clean engine oil.
3. Install the NEW crankshaft position sensor seal, O-ring, onto the crankshaft position sensor.

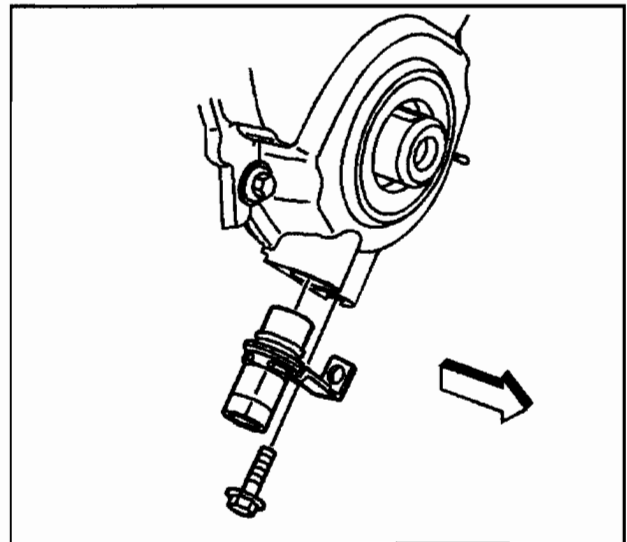


387759

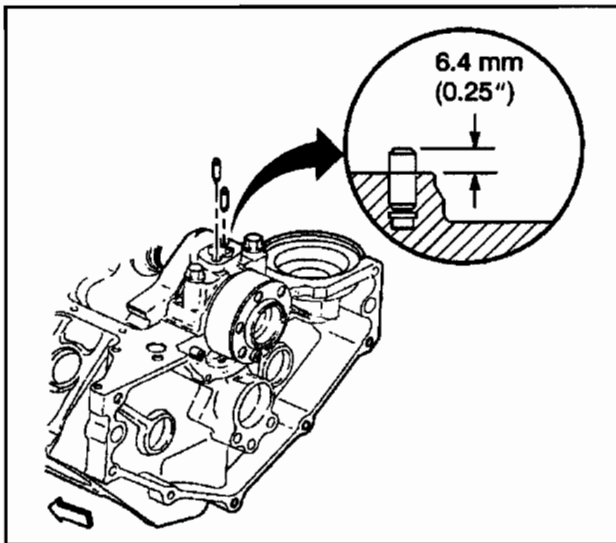
4. Install the crankshaft position sensor.
5. Install the crankshaft position sensor bolt.

Tighten

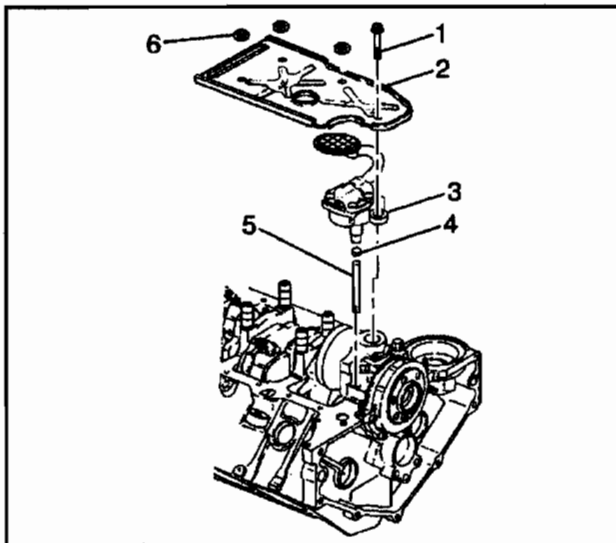
Tighten the crankshaft position sensor bolt to 9 N·m (80 lb in).



11485



182852



11438

Oil Pump, Pump Screen and Deflector Installation

SIE-ID = 194869

Tools Required

J 36660-A Torque Angle Meter

1. Inspect for properly installed oil pump locator pins.

Important: Do not reuse the oil pump driveshaft retainer (4).

During assembly, install a NEW oil pump driveshaft retainer.

2. Assemble the oil pump (3), the oil pump driveshaft (5), and a NEW oil pump driveshaft retainer (4).

3. Install the oil pump (3).

Position the oil pump onto the pins.

Notice: Refer to *Fastener Notice* in Cautions and Notices.

4. Install the crankshaft oil deflector (2) and the nuts (6).
5. Install the bolt (1) attaching the oil pump to the rear crankshaft bearing cap.

Tighten

- Tighten the oil pump bolt on the first pass to 20 N·m (15 lb ft).
- Tighten the oil pump bolt on the final pass to 65 degrees using the J 36660-A.
- Tighten the crankshaft oil deflector nuts to 40 N·m (30 lb ft).

Oil Pan Installation

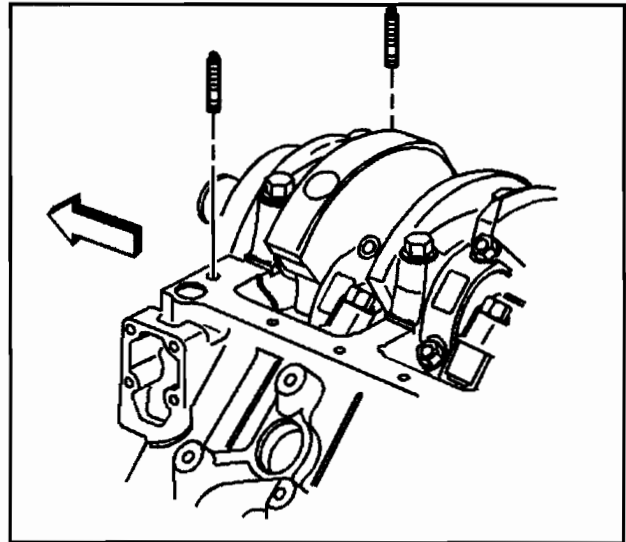
SIE-ID = 66859

Notice: Refer to *Fastener Notice* in Cautions and Notices.

1. Install the oil pan studs into the engine block.

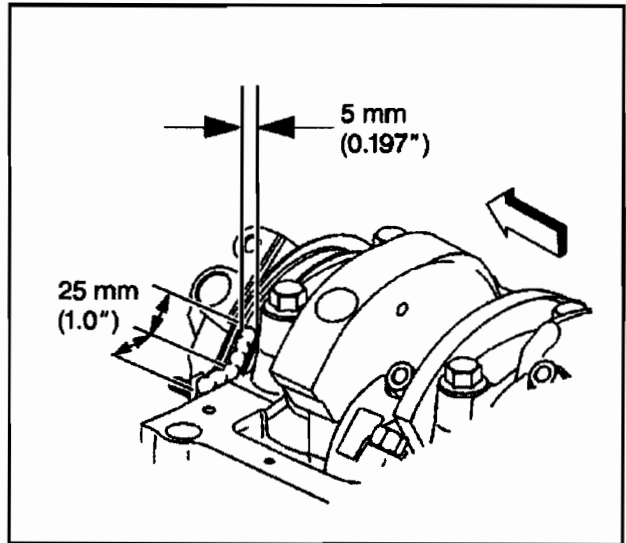
Tighten

Tighten the oil pan studs to 6 N·m (53 lb in).



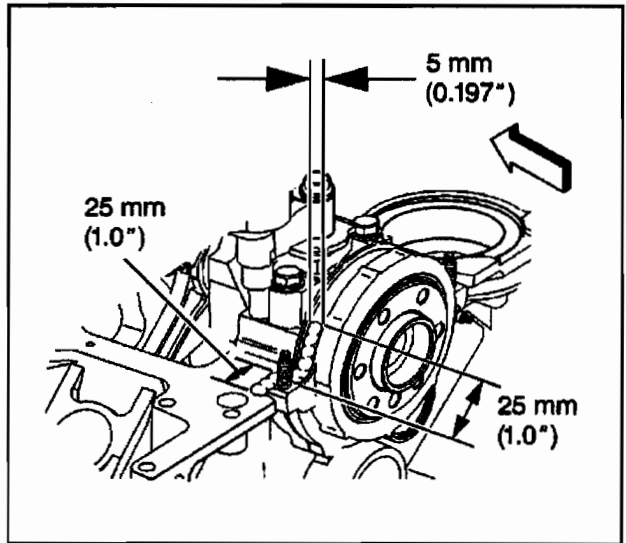
521817

2. Apply a 5 mm (0.197 in) wide and 25 mm (1.0 in) long bead of adhesive GM P/N United States 12346141, GM P/N Canada 10953433, or equivalent, to the engine front cover to engine block junction at the oil pan sealing surfaces.

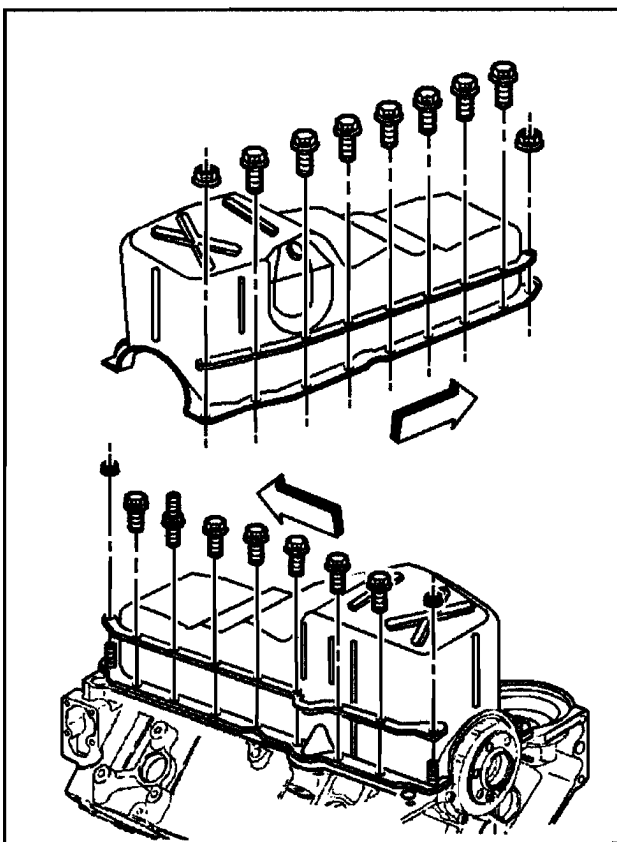


317310

3. Apply a 5 mm (0.197 in) wide and 25 mm (1.0 in) long bead of adhesive GM P/N United States 12346141, GM P/N Canada 10953433, or equivalent, to the crankshaft rear oil seal housing to engine block junction at the oil pan sealing surfaces.



317313



182851

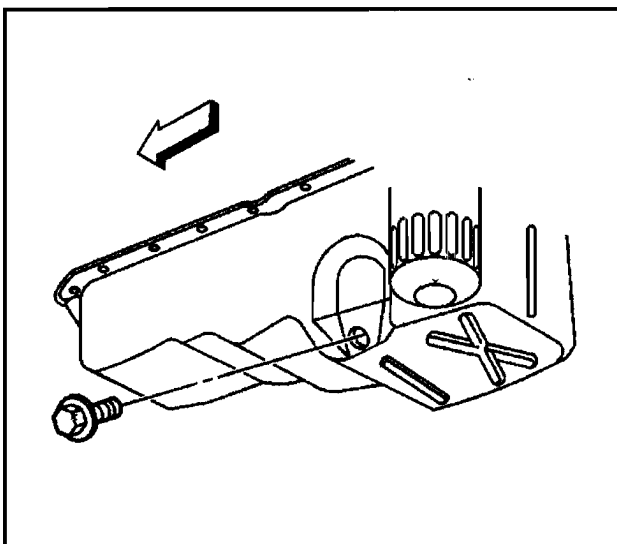
Important: Always install a NEW oil pan gasket.

The oil pan gasket and oil pan must be installed and the fasteners tightened while the adhesive is still wet to the touch.

4. Install the NEW oil pan gasket.
5. Install the oil pan.
Press the oil pan gasket into the grooves of the engine front cover and crankshaft rear oil seal housing.
6. Install the oil pan reinforcements.
7. Install the nuts and the bolts.

Tighten

- 7.1. Tighten the oil pan bolts to 12 N·m (106 lb in).
- 7.2. Tighten the oil pan nuts to 25 N·m (18 lb ft).



182850

8. Install a NEW oil pan drain plug seal, O-ring, onto the oil pan drain plug.
9. Install the oil pan drain plug into the oil pan.

Tighten

Tighten the oil pan drain plug to 25 N·m (18 lb ft).

Oil Filter Adapter Installation

SIE-ID = 68508

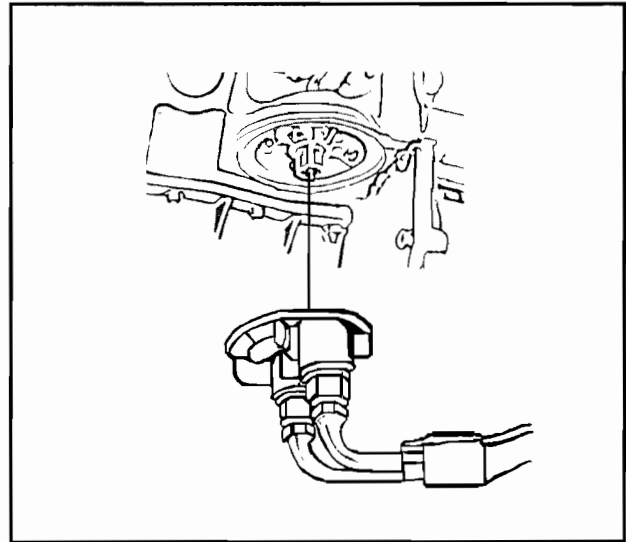
1. Apply clean engine oil GM P/N United States 12345610, GM P/N Canada 993193, or equivalent, to the NEW oil filter adapter seal, O-ring, if applicable.
2. Install the NEW oil filter adapter seal into the groove in the oil filter adapter, if applicable.
3. Install the NEW oil filter adapter gasket, if applicable, and the oil filter adapter.

Notice: Refer to *Fastener Notice* in Cautions and Notices.

4. Install the oil filter adapter flat washers, if applicable, and the oil filter adapter bolts.

Tighten

Tighten the oil filter adapter bolts to 25 N·m (18 lb ft).



39122

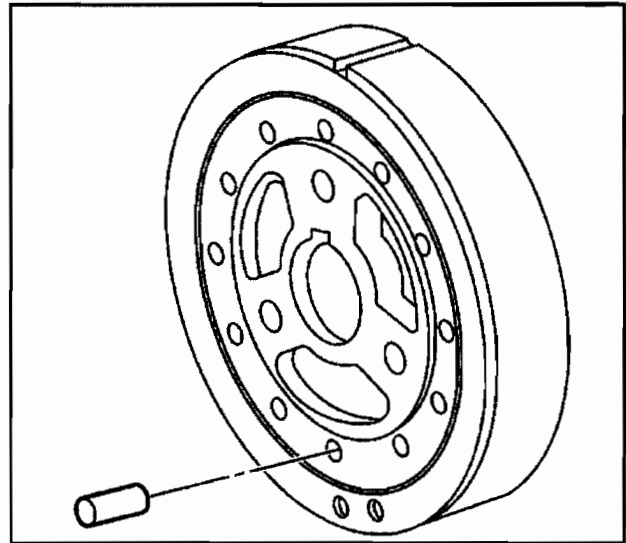
Crankshaft Balancer Installation

SIE-ID = 66868

Tools Required

J 23523-F Balancer Remover and Installer

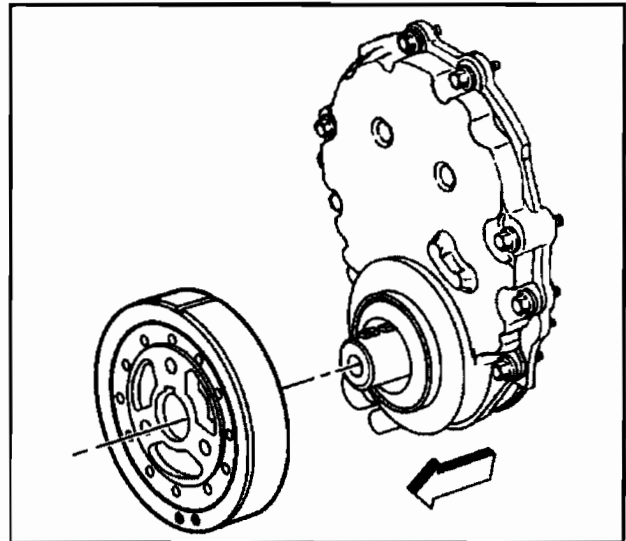
1. Ensure that the crankshaft balancer front groove pin is the proper length and installed in the proper location, if applicable.



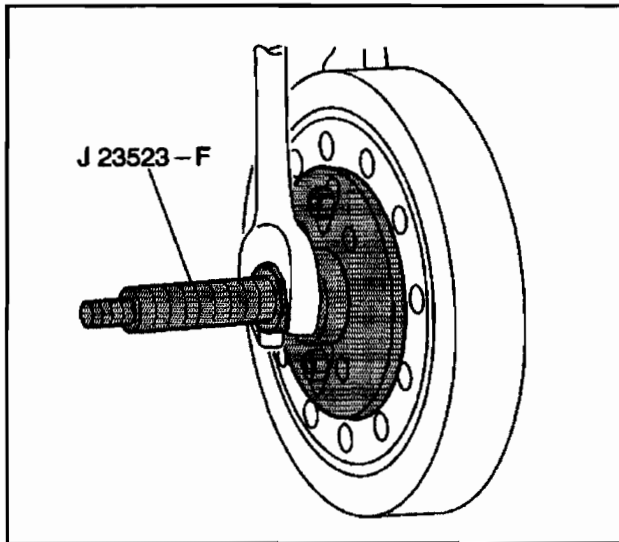
182849

Notice: SIO-ID = 16580 The inertial weight section of the crankshaft balancer is assembled to the hub with a rubber type material. The correct installation procedures (with the proper tool) must be followed or movement of the inertial weight section of the hub will destroy the tuning of the crankshaft balancer.

2. Apply a small amount of adhesive GM P/N United States 12346141, GM P/N Canada 10953433, or equivalent, onto the crankshaft balancer keyway in order to seal the crankshaft balancer keyway and crankshaft joint.
3. Install the crankshaft balancer onto the end of the crankshaft.
Align the keyway of the crankshaft balancer with the crankshaft balancer woodruff key.
4. Install the crankshaft balancer onto the end of the crankshaft.



182832



4065

Notice: Refer to *Fastener Notice* in Cautions and Notices.

5. Use the *J 23523-F* in order to press the crankshaft balancer onto the crankshaft.

- 5.1. Install the *J 23523-F* plate and bolts onto the front of the crankshaft balancer.

Tighten

Tighten the *J 23523-F* plate bolts to 25 N·m (18 lb ft).

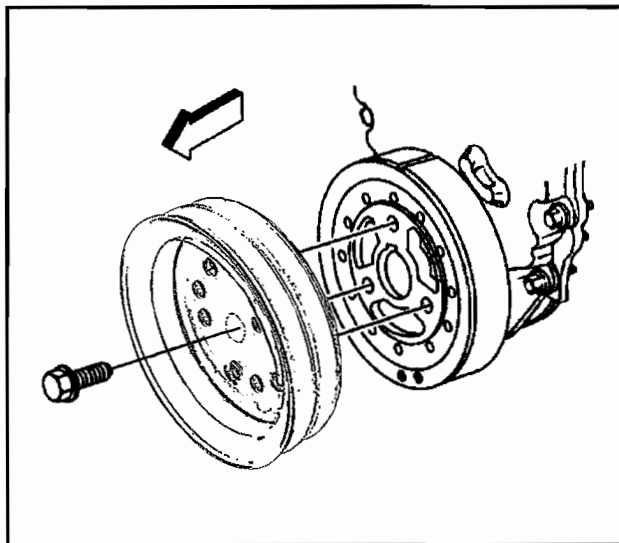
- 5.2. Install the *J 23523-F* screw into the end for the crankshaft.
- 5.3. Install the *J 23523-F* bearing, the washer, and the nut onto the *J 23523-F* screw.
- 5.4. Rotate the *J 23523-F* nut clockwise until the crankshaft balancer hub is completely seated against the crankshaft position sensor reluctor ring.

6. Remove the *J 23523-F*.

7. Install the crankshaft pulley and bolts.

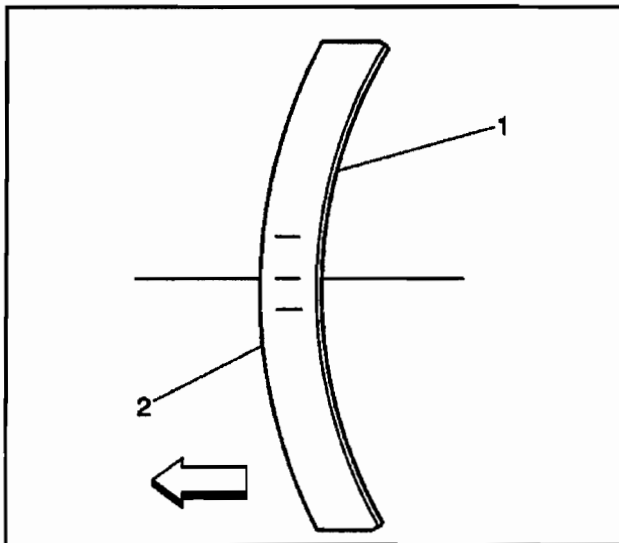
Tighten

Tighten the crankshaft pulley bolts to 58 N·m (43 lb ft).



188055

8. Ensure that the crown of the crankshaft balancer washer (2) is faced away from the engine.

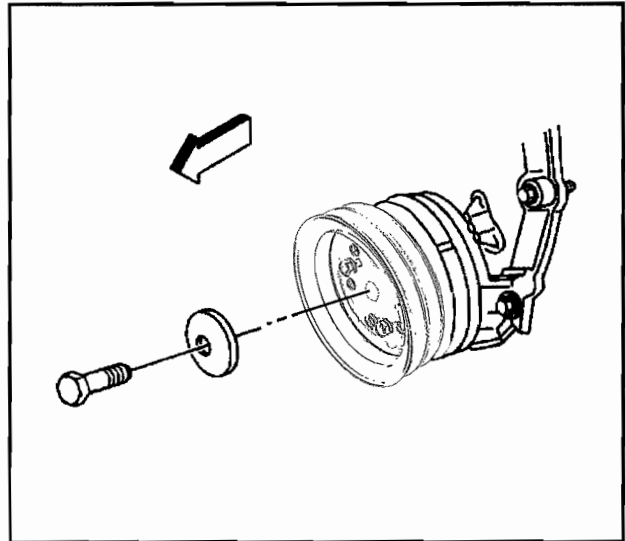


342203

9. Install the crankshaft balancer washer and the bolt.

Tighten

Tighten the crankshaft balancer bolt to 95 N·m (70 lb ft).



173172

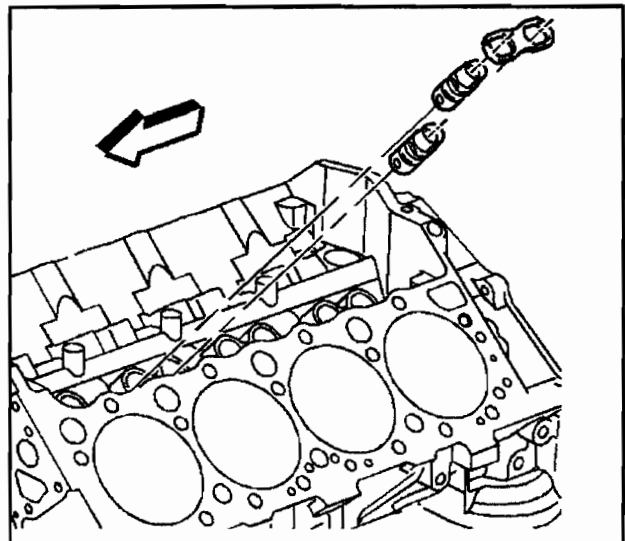
Valve Lifter Installation

SIE-ID = 69825

1. Apply lubricant GM P/N United States 12345501, GM P/N Canada 992704, or equivalent, to the valve lifter rollers.

Important: If reusing the valve lifters, install the valve lifters in the original positions.

2. Install the valve lifters.



11509

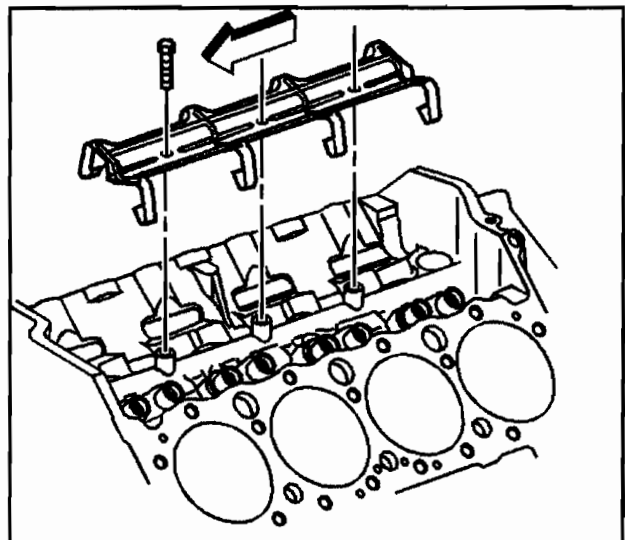
3. Install the valve lifter guides.
4. Install the valve lifter guide retainer.

Notice: Refer to *Fastener Notice* in Cautions and Notices.

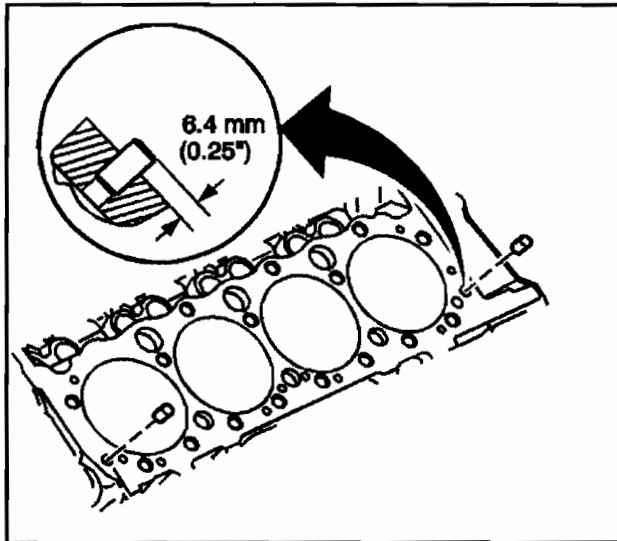
5. Install the valve lifter guide retainer bolts.

Tighten

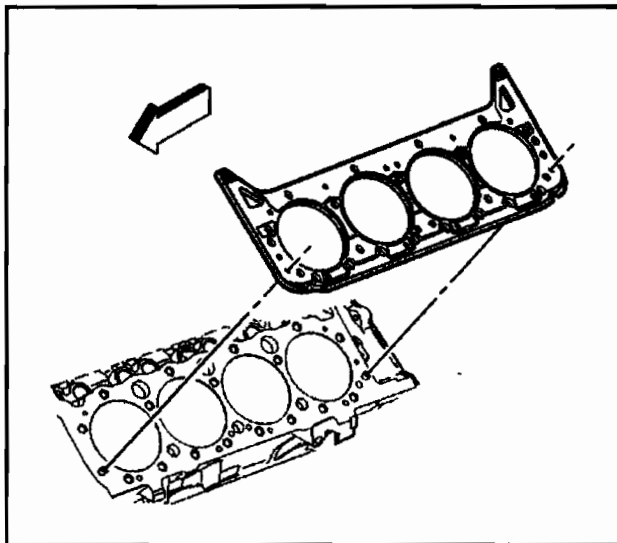
Tighten the valve lifter guide retainer bolts to 25 N·m (18 lb ft).



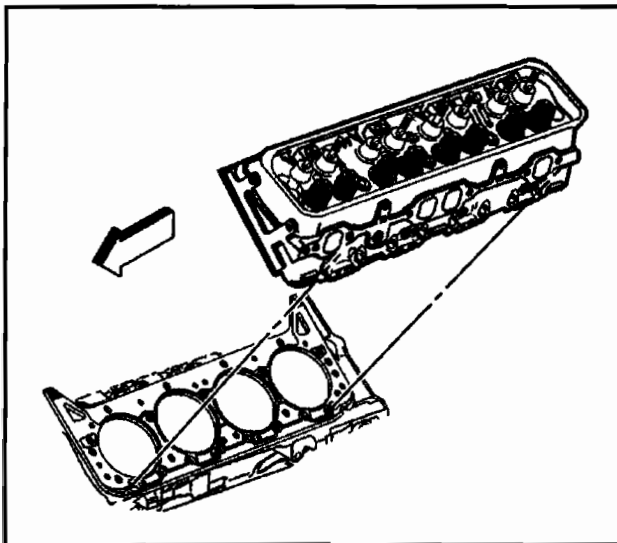
11508



182846



317233



317227

Cylinder Head Installation - Left

SIE-ID = 650067

Tools Required

J 36660-A Torque Angle Meter

1. Clean the cylinder gasket surfaces on the engine block.
2. Inspect the cylinder head locator dowel pins for proper installation.
3. Clean the cylinder head gasket surfaces on the cylinder head.

Important: Do not use any type sealer on the cylinder head gasket, unless specified.

4. Place the NEW cylinder head gasket in position over the cylinder head locator dowel pins.
The cylinder head gasket is not directional and may be installed using either side facing the engine block.

5. Install the cylinder head to the engine block.
Guide the cylinder head carefully into place over the dowel pins and the cylinder head gasket.

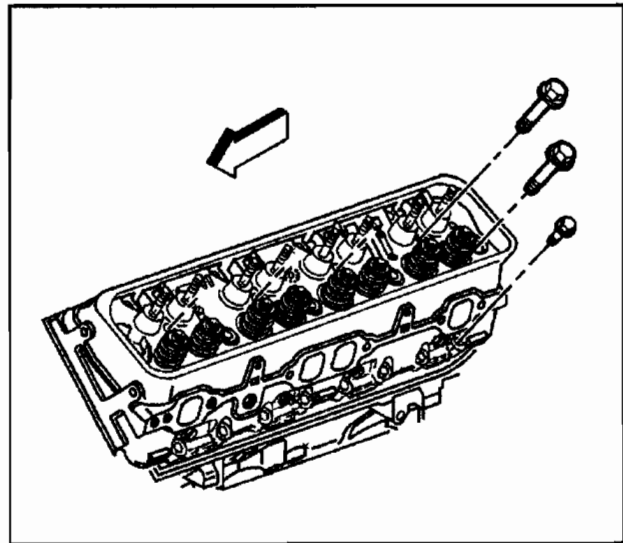
6. Apply sealant GM P/N United States 12346004, GM P/N Canada 10953480, or equivalent, to the threads of the cylinder head bolts.

Notice: Refer to *Fastener Notice* in Cautions and Notices.

7. Install the cylinder head bolts.

Tighten

Tighten the bolts in sequence on the first pass to 30 N·m (22 lb ft).

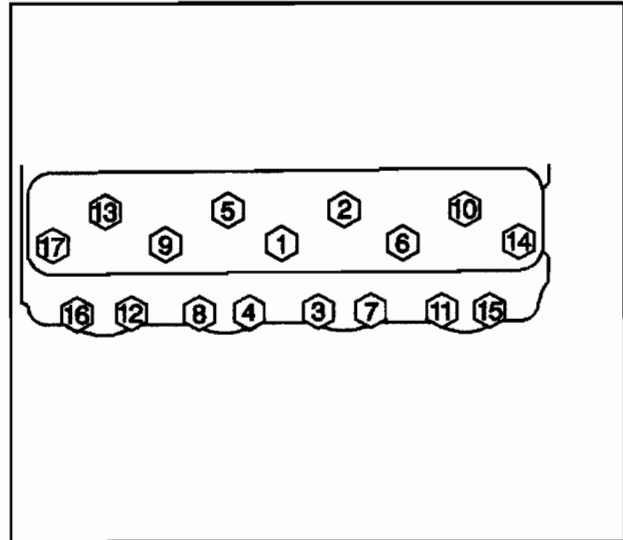


317217

8. Use the *J 36660-A* in order to tighten the cylinder head bolts in sequence on the final pass.

Tighten

- Tighten the long bolts (1, 2, 5, 6, 9, 10, and 13) on the final pass in sequence to 75 degrees.
- Tighten the medium bolts (14 and 17) on the final pass in sequence to 65 degrees.
- Tighten the short bolts (3, 4, 7, 8, 11, 12, 15, and 16) on the final pass in sequence to 55 degrees.



500687

9. Measure the NEW spark plugs for the proper gap. Adjust the spark plug gap if necessary.

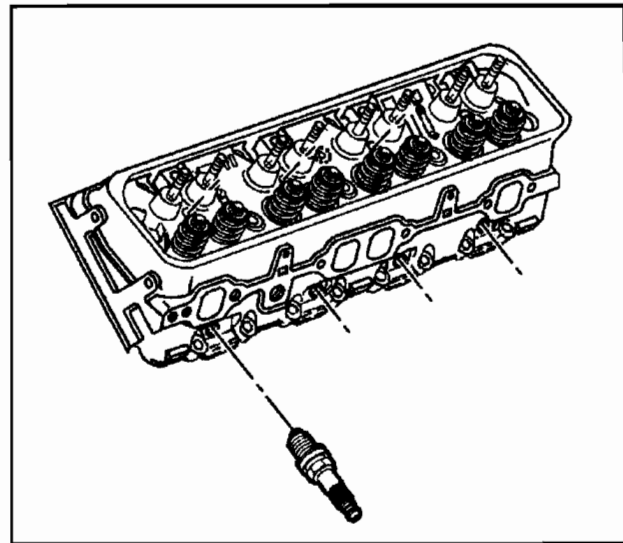
Specification

Spark plug gap to 1.52 mm (0.060 in)

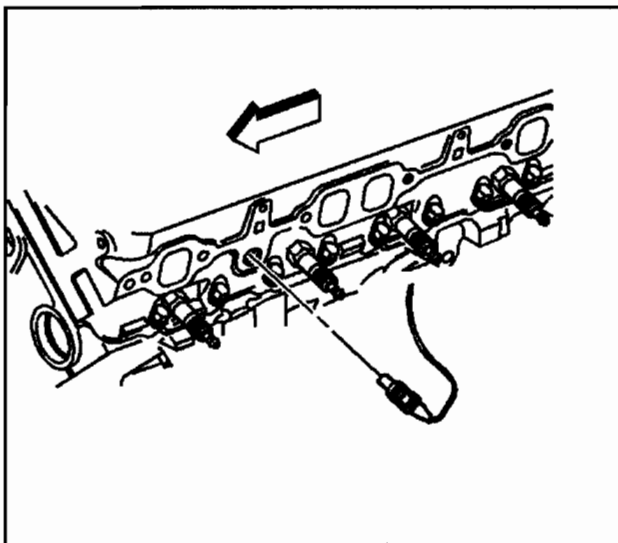
10. Install the NEW spark plugs.

Tighten

- Tighten the spark plugs for a USED cylinder head to 15 N·m (11 lb ft).
- Tighten the spark plugs for the initial installation of a NEW cylinder head to 30 N·m (22 lb ft).



317307

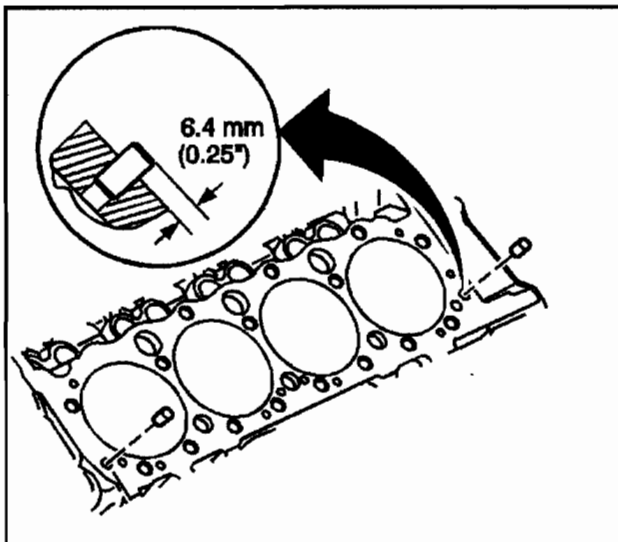


521828

11. If reusing the engine coolant temperature (ECT) gage sensor, apply sealant GM P/N United States 12346004, GM P/N Canada 10953480 to the threads of the ECT gage sensor.
12. Install the ECT gage sensor.

Tighten

Tighten the ECT gage sensor to 20 N·m (15 lb ft).



182846

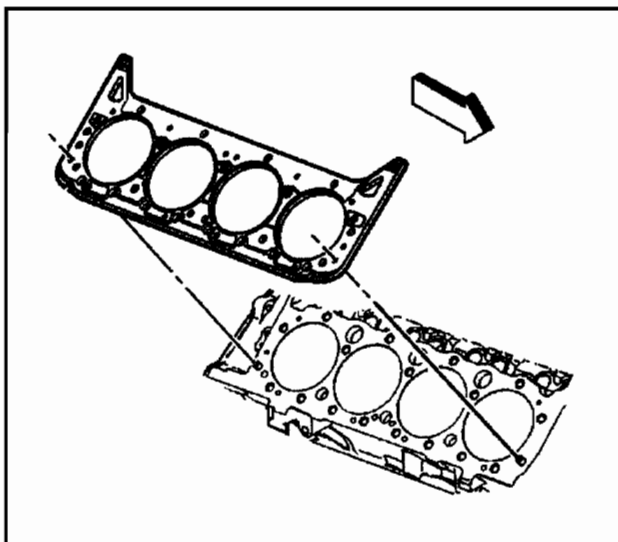
Cylinder Head Installation - Right

SIE-ID = 650068

Tools Required

J 36660-A Torque Angle Meter

1. Clean the cylinder gasket surfaces on the engine block.
2. Inspect the cylinder head locator dowel pins for proper installation.
3. Clean the cylinder head gasket surfaces on the cylinder head.

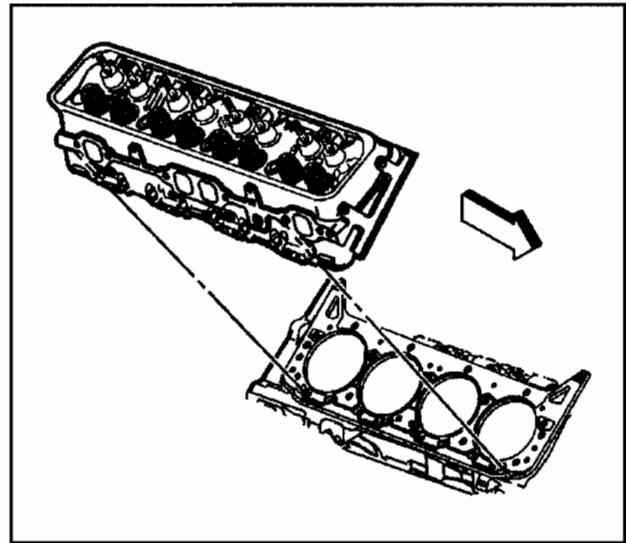


317255

Important: Do not use any type sealer on the cylinder head gasket, unless specified.

4. Place the NEW cylinder head gasket in position over the cylinder head locator dowel pins.
The cylinder head gasket is not directional and may be installed using either side facing the engine block.

5. Install the cylinder head to the engine block.
Guide the cylinder head carefully into place over the dowel pins and the head gasket.



317246

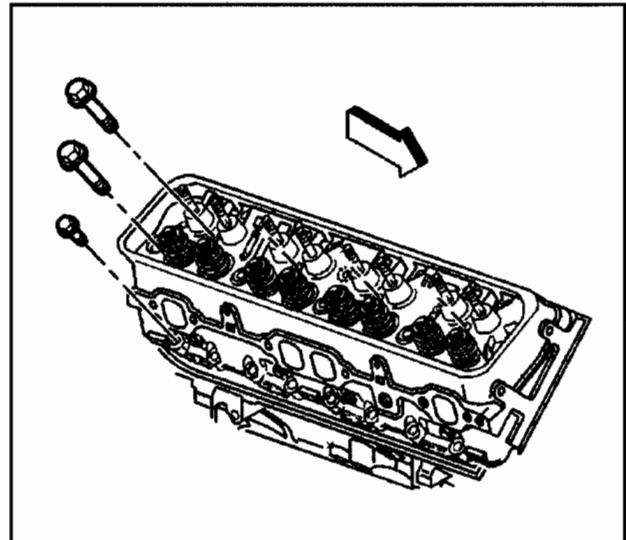
6. Apply sealant GM P/N United States 12346004, GM P/N Canada 10953480, or equivalent, to the threads of the cylinder head bolts.

Notice: Refer to *Fastener Notice* in Cautions and Notices.

7. Install the cylinder head bolts.

Tighten

Tighten the bolts in sequence on the first pass to 30 N·m (22 lb ft).

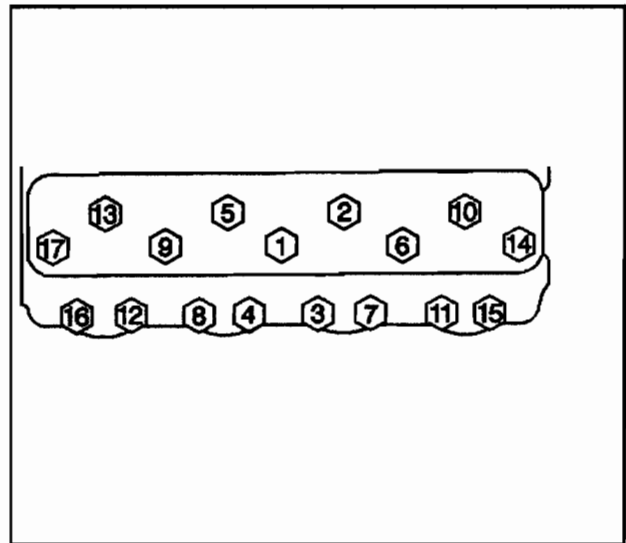


317239

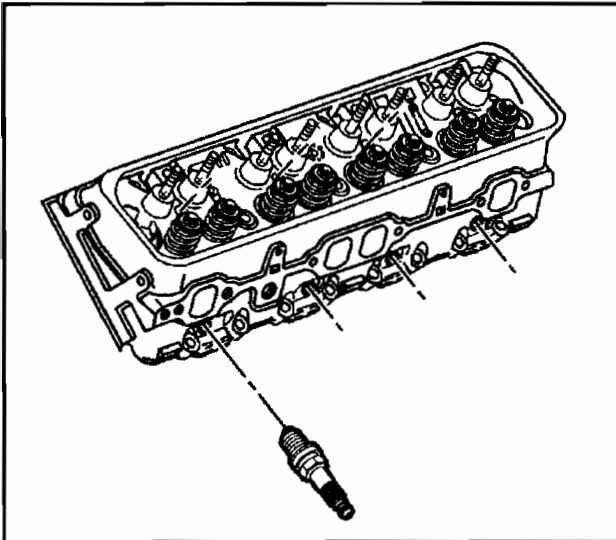
8. Use the *J 36660-A* in order to tighten the cylinder head bolts in sequence on the second pass.

Tighten

- Tighten the long bolts (1, 2, 5, 6, 9, 10, and 13) on the second pass in sequence to 75 degrees.
- Tighten the medium bolts (14 and 17) on the second pass in sequence to 65 degrees.
- Tighten the short bolts (3, 4, 7, 8, 11, 12, 15, and 16) on the second pass in sequence to 55 degrees.



500687



317307

9. Measure the NEW spark plugs for the proper gap. Adjust the spark plug gap, if necessary.

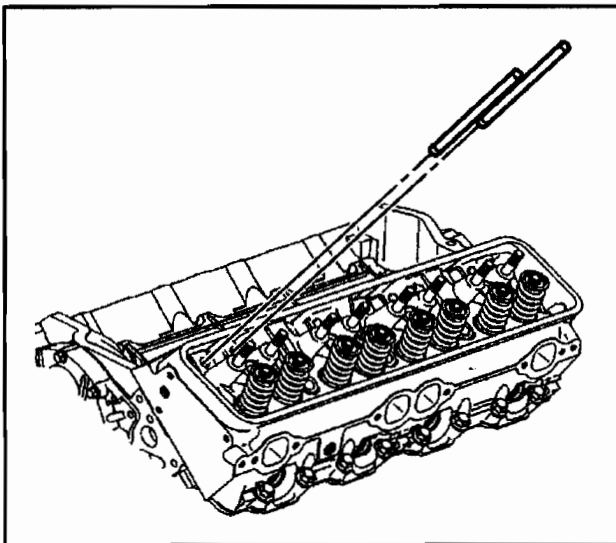
Specifications

Spark plug gap to 1.52 mm (0.060 in).

10. Install the NEW spark plugs.

Tighten

- Tighten the spark plugs for a USED cylinder head to 15 N·m (11 lb ft).
- Tighten the spark plugs for the initial installation of a NEW cylinder head to 30 N·m (22 lb ft).



22766

Valve Rocker Arm and Push Rod Installation

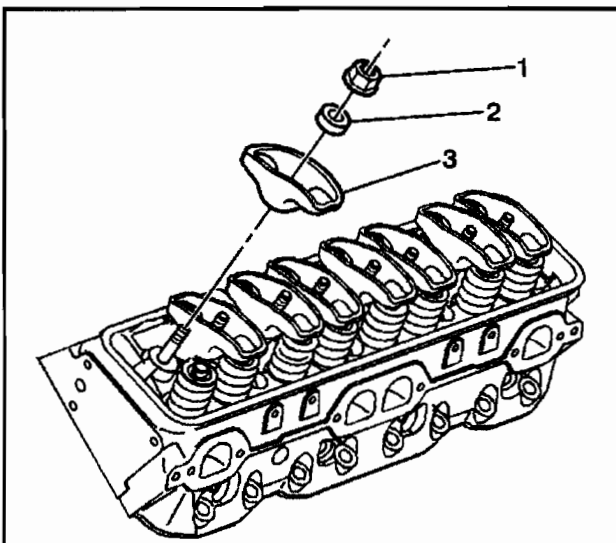
SIE-ID = 194762

Important: Be sure to keep parts in order. Parts must be put back from where they were removed.

1. Apply prelube GM P/N United States 12345501, GM P/N Canada 942704, or equivalent, to the valve rocker arm and the valve rocker arm ball bearing surfaces.

Important: Be sure that the valve pushrods seat in the valve lifter sockets.

2. Install the valve pushrods.



182835

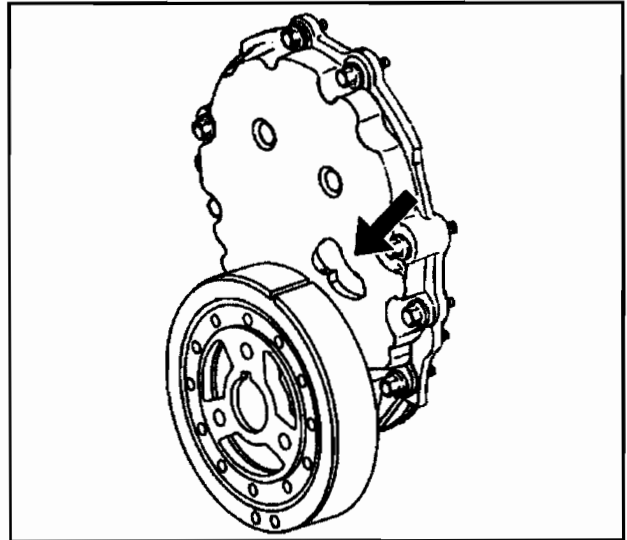
3. Install the following parts:

- 3.1. The valve rocker arm nuts (1)
- 3.2. The valve rocker arm balls (2)
- 3.3. The valve rocker arms (3)

Valve Lash Adjustment

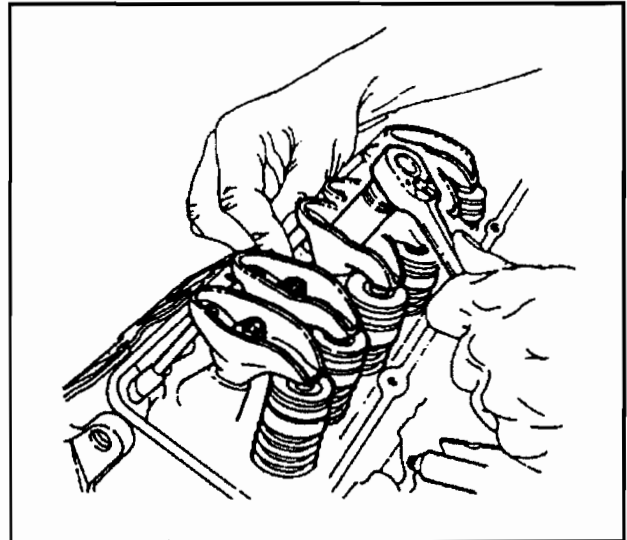
SIE-ID = 194734

1. Turn the valve rocker arm nuts clockwise until all of the valve lash is removed.
2. Turn the crankshaft clockwise until the alignment mark on the crankshaft balancer is aligned with the notch in the engine front cover tab.
3. Look at the number 1 cylinder valves as the crankshaft balancer alignment mark approaches the notch in the engine front cover tab. If a valve moves as the alignment mark moves into position, the engine is in the number 6 firing position. If this happens, turn the crankshaft clockwise 1 revolution in order to reach the number 1 cylinder firing position.



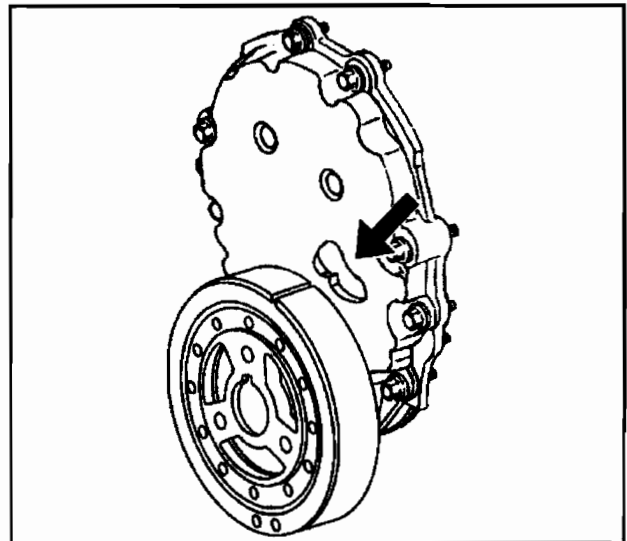
195336

4. With the engine in the number 1 firing position, adjust the exhaust valves for cylinders number 1, 3, 4, and 8 and the intake valves for cylinders number 1, 2, 5, and 7.
 - 4.1. Turn the valve rocker arm nut counter clockwise until the valve lash is felt in the valve pushrod.
 - 4.2. Turn the valve rocker arm nut clockwise until all the valve lash is removed. Zero valve lash can be felt by moving the valve pushrod up and down between your thumb and forefinger until there is no more up and down movement of the valve push rod.
 - 4.3. When all the valve lash is removed, then turn the valve rocker arm nut clockwise 1 additional turn (360 degrees).

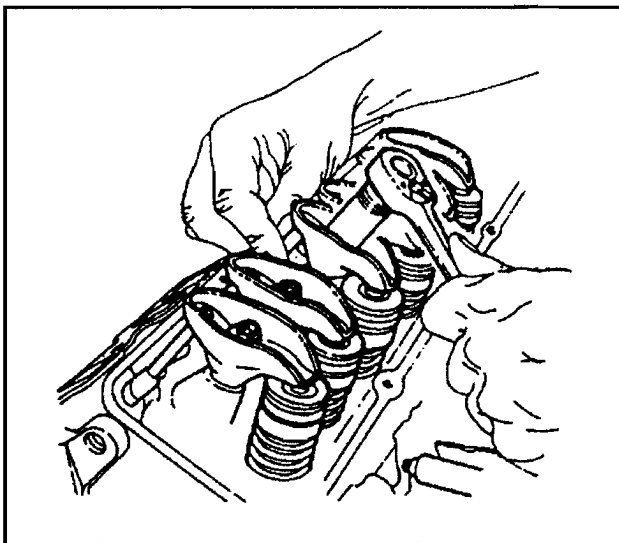


22759

5. Turn the crankshaft clockwise 1 revolution until the alignment mark on the crankshaft balancer is aligned with the notch in the engine front cover tab.



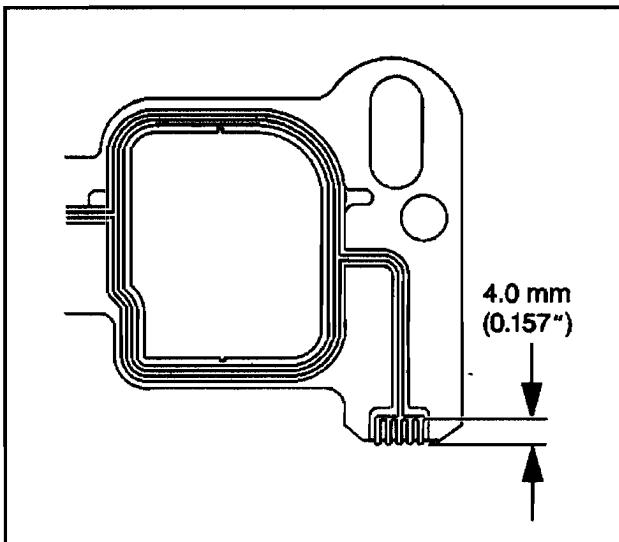
195336



22759

6. With the engine in the number 6 firing position, adjust the exhaust valves for cylinders number 2, 5, 6, and 7 and the intake valves for cylinders number 3, 4, 6, and 8.
 - 6.1. Turn the valve rocker arm nut counter clockwise until the valve lash is felt in the valve pushrod.
 - 6.2. Turn the valve rocker arm nut clockwise until all the valve lash is removed.

Zero valve lash can be felt by moving the valve pushrod up and down between your thumb and forefinger until there is no more up and down movement of the valve push rod.
 - 6.3. When all the valve lash is removed, then turn the valve rocker arm nut clockwise 1 additional turn (360 degrees).



38512

Intake Manifold Installation

SIE-ID = 66866

Notice: SIO-ID = 16302 Apply the proper amount of the sealant when assembling this component. Excessive use of the sealant can prohibit the component from sealing properly. A component that is not sealed properly can leak leading to extensive engine damage.

Important: The lower intake manifold must be installed and the fasteners tightened while the adhesive is still wet to the touch.

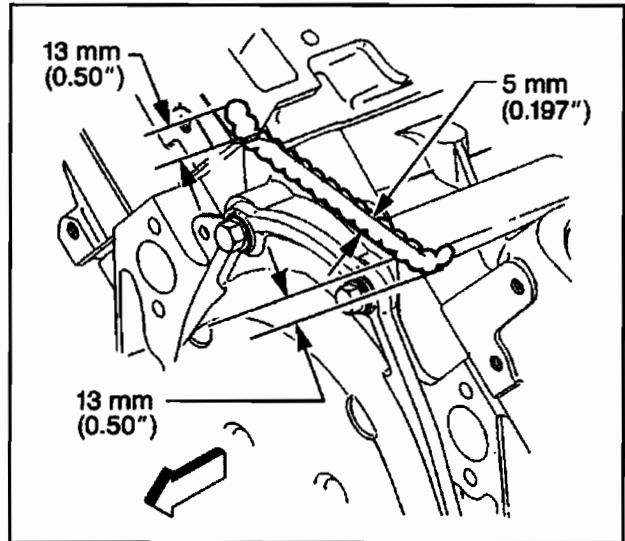
1. Apply a 4.0 mm (0.157 in) patch of adhesive GM P/N United States 12346141, GM P/N Canada 10953433, or equivalent, to the cylinder head side of the lower intake manifold gasket at each end.
2. Install the lower intake manifold gasket onto the cylinder head.

Use the gasket locator pins in order to properly seat the lower intake manifold gasket onto the cylinder head.

Notice: SIO-ID = 41431 Apply the proper amount of the sealant when assembling this component. Excessive use of the sealant can prohibit the component from sealing properly. A component that is not sealed properly can leak leading to extensive engine damage.

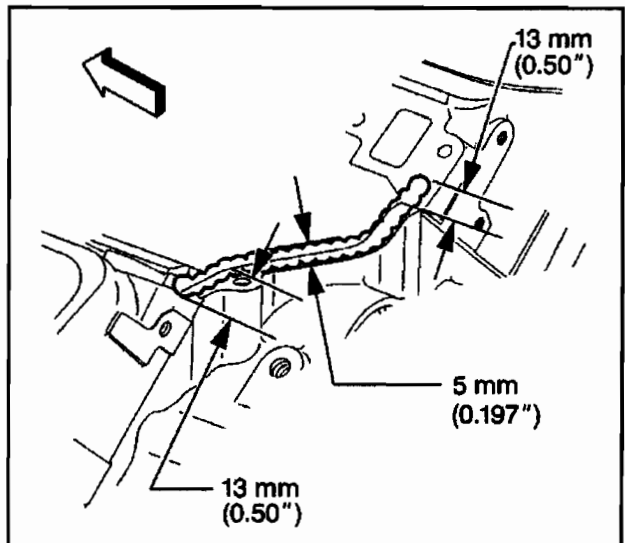
Important: All sealing surfaces must be clean, free of oil, dirt, or any other foreign material.

3. Apply a 5 mm (0.197 in) bead of adhesive GM P/N United States 12346141, GM P/N Canada 10953433, or equivalent, to the front top of the engine block.
4. Extend the adhesive bead 13 mm (0.50 in) onto the each lower intake manifold gasket.



26744

5. Apply a 5 mm (0.197 in) bead of adhesive GM P/N United States 12346141, GM P/N Canada 10953433, or equivalent, to the rear top of the engine block.
6. Extend the adhesive bead 13 mm (0.50 in) onto each lower intake manifold gasket.

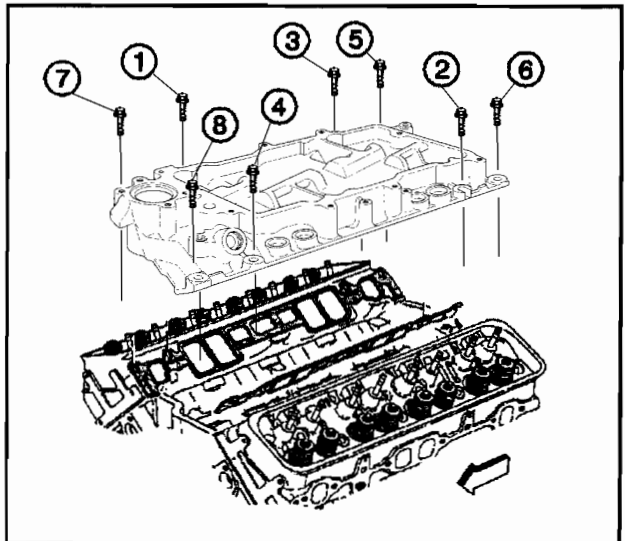


26743

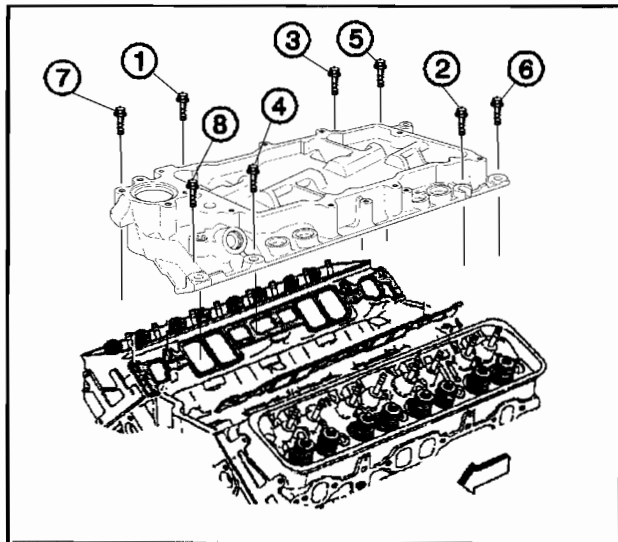
7. Install the lower intake manifold onto the engine block and the cylinder heads.

Notice: Refer to *Fastener Notice* in Cautions and Notices.

8. Apply threadlock GM P/N United States 12345382, GM P/N Canada 10953489, or equivalent, to the threads of the lower intake manifold bolts.



66456



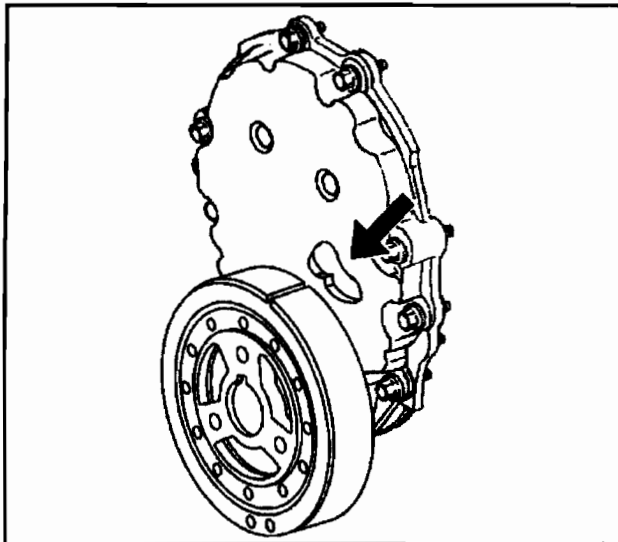
670680

Notice: SIO-ID = 382467 Proper lower intake manifold fastener tightening sequence and torque is critical. Always follow the tightening sequence, and torque the intake manifold bolts using the 3 step method. Failing to do so may distort the crankshaft bearing bore alignment and cause damage to the crankshaft bearings.

9. Install the lower intake manifold bolts.

Tighten

- 9.1. Tighten the bolts on the first pass in sequence (1–8) to 3 N·m (27 lb in).
- 9.2. Tighten the bolts on the second pass in sequence (1–8) to 12 N·m (106 lb in).
- 9.3. Tighten the bolts on the final pass in sequence (1–8) to 15 N·m (11 lb ft).



195336

Distributor Installation

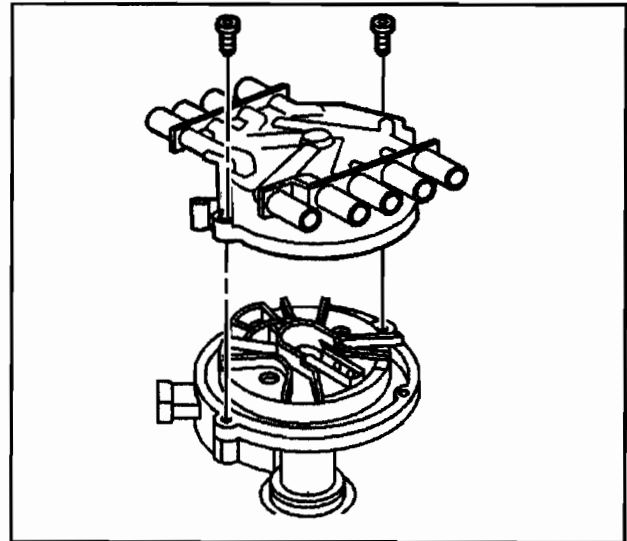
SIE-ID = 69509

Important: Cylinder number 1 MUST be 15 degrees Before Top Dead Center (BTDC).

1. Bring cylinder number one piston to 15 degrees Before Top Dead Center (BTDC) of the compression stroke.

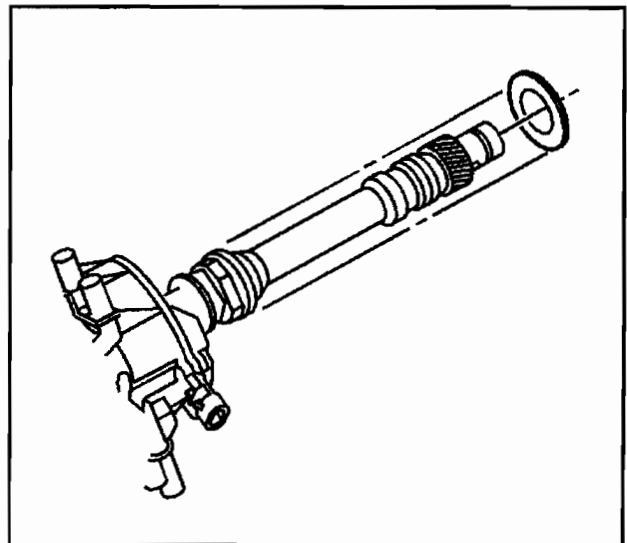
The saw mark on the harmonic balancer will be about 1 inch before the timing mark on the timing chain cover. 15 degrees can be calculated by measuring the circumference of the harmonic balancer and dividing that number by 360, then multiply that by 15 and it will give the measurement equal to 15 degrees.

2. Remove the distributor cap bolts and discard.
3. Remove the distributor cap.



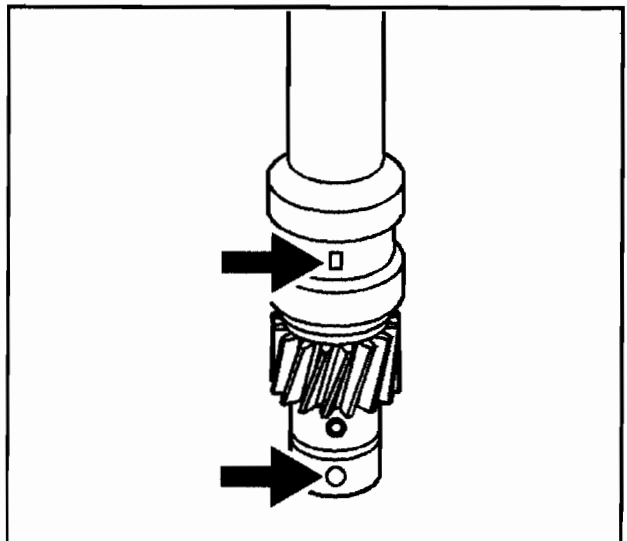
500690

4. Install a NEW distributor gasket onto the distributor.

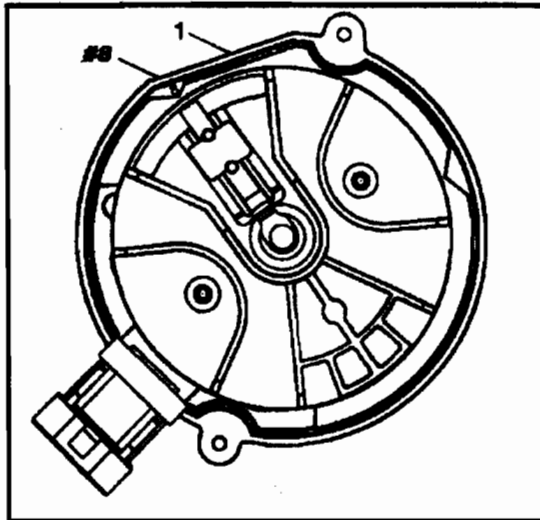


523516

5. Align the indent hole on the driven gear with the paint mark on the distributor housing.
6. Align the slotted tang in the oil pump driveshaft with the distributor driveshaft.
Rotate the oil pump driveshaft with a screwdriver if necessary.
7. Align the flat (1) in the distributor housing toward the front of the engine.
8. Install the distributor into the engine, making sure that it seats all the way down, flush with the intake manifold.

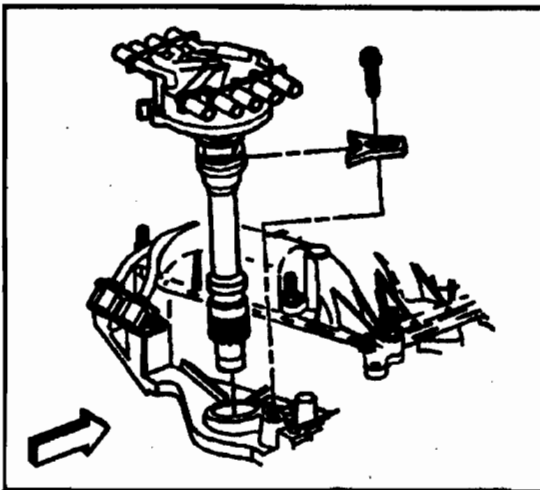


492137



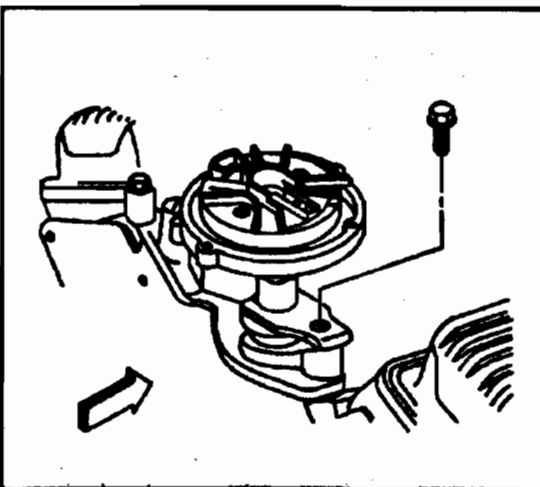
68506

9. Once the distributor is fully seated, align the distributor rotor segment with the number 8 pointer that is cast into the distributor base.
10. If the distributor rotor segment does not come within a few degrees of the number 8 pointer, the gear mesh between the distributor and camshaft may be off a tooth or more. Repeat the procedure in order to achieve proper alignment.



68303

11. Install the distributor clamp bolt. Do not tighten at this point. If using a distributor alignment tool such as Rinda part number 94060, rotate the distributor clockwise until the light comes on, then rotate the distributor counterclockwise until the light just goes off.



38800

Notice: Refer to *Fastener Notice* in *Cautions and Notices*.

12. Once the light is off, tighten the distributor clamp bolt.
Tighten
Tighten the distributor clamp bolt to 25 N-m (18 lb ft).

If using a hand-held scan tool, snug the distributor hold down clamp bolt so that the distributor can still be turned by hand and start the engine. With the scan tool reading "Cam Retard," and the engine running at 1000 RPM, a reading of 40 to 50 degrees must be seen in order to prevent engine cross-fire. If "Cam Retard" is not within specifications, rotate distributor until the desired reading is displayed.

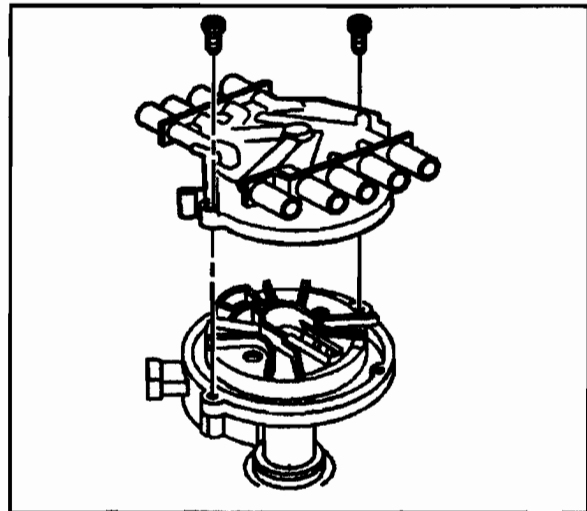
Tighten

Tighten the distributor clamp bolt to 25 N-m (18 lb ft).

13. Install the distributor cap onto the distributor.
14. Install the NEW distributor cap bolts.
Do not overtighten the NEW distributor cap bolts.

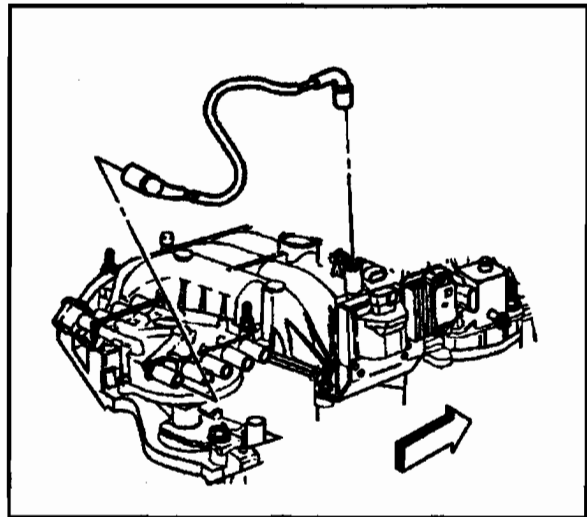
Tighten

Tighten the distributor cap bolts to 2.4 N-m (21 lb in).



500690

15. Install the ignition coil wire harness.



341359

Valve Rocker Arm Cover Installation - Left

SRE-ID = 650069

Important: Always install a NEW valve rocker arm cover gasket.

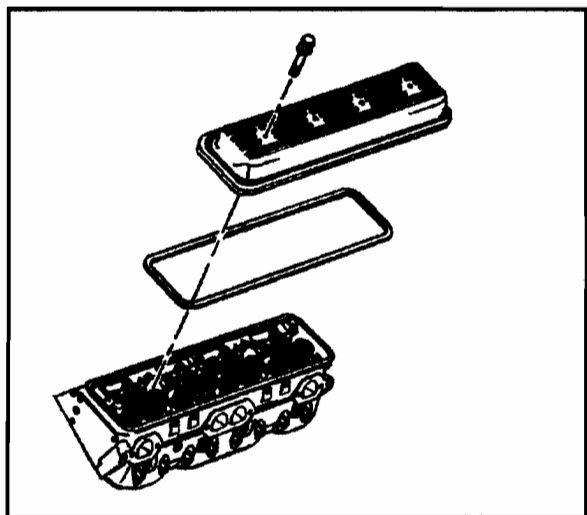
1. Install the NEW valve rocker arm cover gasket.
2. Install the valve rocker arm cover.

Notice: Refer to *Fastener Notice* in Cautions and Notices.

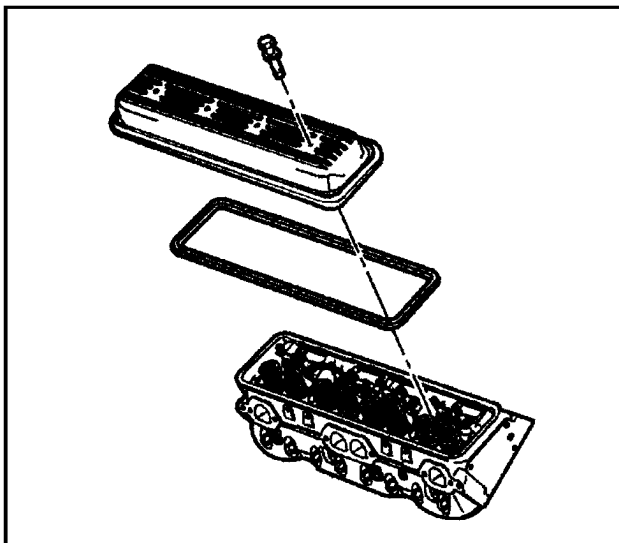
3. Install the valve rocker arm cover washers and bolts.

Tighten

Tighten the bolts to 12 N-m (106 lb in).



39119



182833

Valve Rocker Arm Cover Installation - Right

SIE-ID = 650070

Important: Always install a NEW valve rocker arm cover gasket.

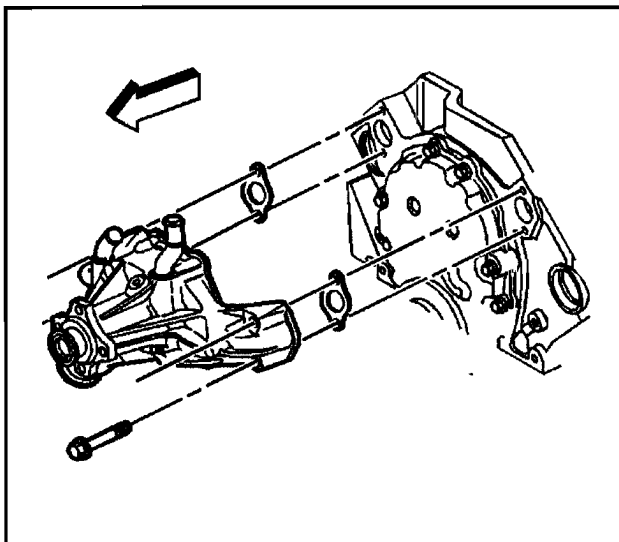
1. Install the NEW valve rocker arm cover gasket.
2. Install the valve rocker arm cover.

Notice: Refer to *Fastener Notice* in Cautions and Notices.

3. Install the valve rocker arm cover washers and bolts.

Tighten

Tighten the bolts to 12 N·m (106 lb in).



69011

Water Pump Installation

SIE-ID = 69040

Tools Required

J 41240 Fan Clutch Remover and Installer

1. Apply sealant GM P/N United States 12346004, GM P/N Canada 10953480, or equivalent, to the threads of the water pump bolts.
2. Install NEW water pump gaskets.
3. Install the water pump.

Notice: Refer to *Fastener Notice* in Cautions and Notices.

4. Install the water pump bolts.

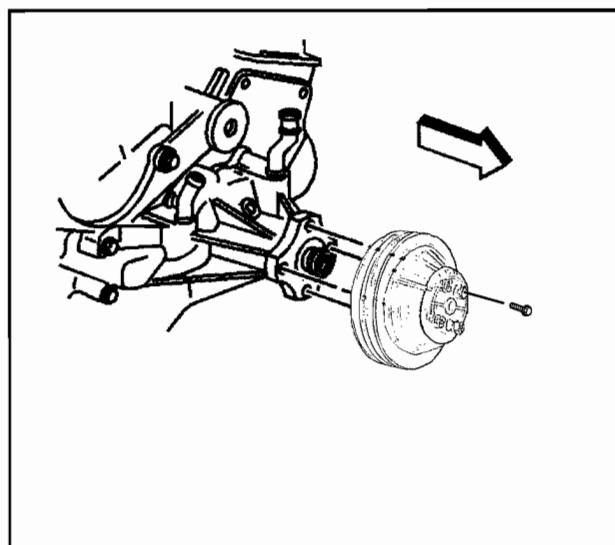
Tighten

Tighten the water pump bolts to 45 N·m (33 lb ft).

6. Install the fan and water pump pulley and bolts

Tighten

Tighten the fan and water pump pulley bolts to 25 N·m (18 lb ft).



317191

Oil Level Indicator and Tube Installation

SIE-ID = 349357

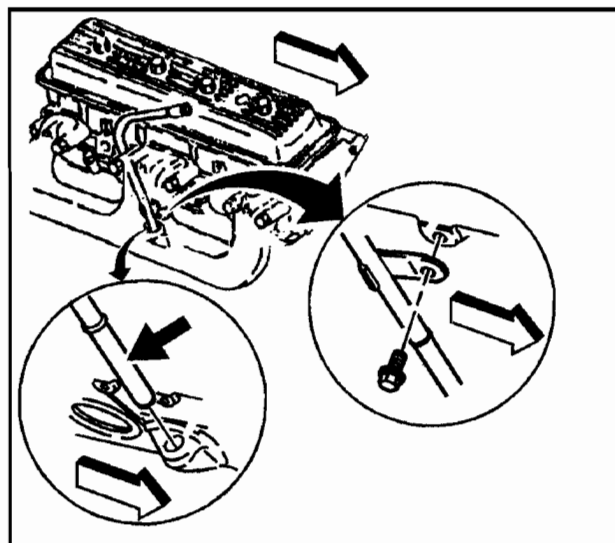
1. Apply sealant GM P/N United States 12346004, GM P/N Canada 10953480, or equivalent, around the oil level indicator tube 13 mm (0.5 in) below the tube bead.
2. Install the oil level indicator tube into the engine block. Rotate the oil level indicator tube into position.

Notice: Refer to *Fastener Notice* in Cautions and Notices.

3. Install the oil level indicator tube bolt.

Tighten

Tighten the oil level indicator tube bolt to 25 N·m (18 lb ft).



500691

Exhaust Manifold Installation

SIE-ID = 650071

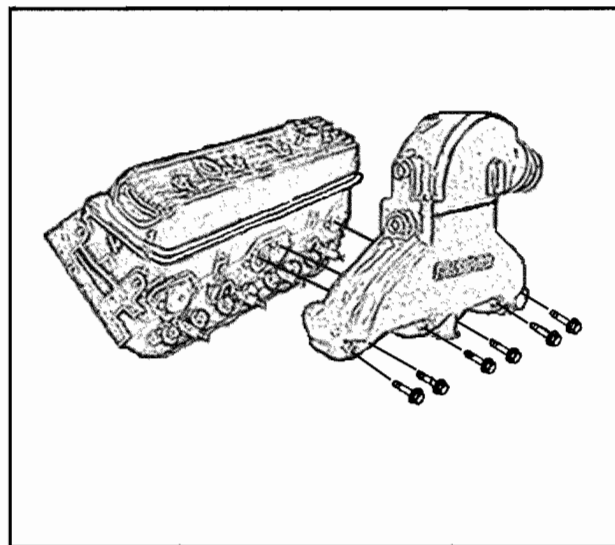
1. Install the NEW exhaust manifold gasket.
2. Install the exhaust manifold.
3. Install the spark plug wire shields.
4. Apply threadlock GM P/N United States 12345493, GM P/N Canada 10953488, or equivalent, to the threads of the exhaust manifold bolts.

Notice: Refer to *Fastener Notice* in Cautions and Notices.

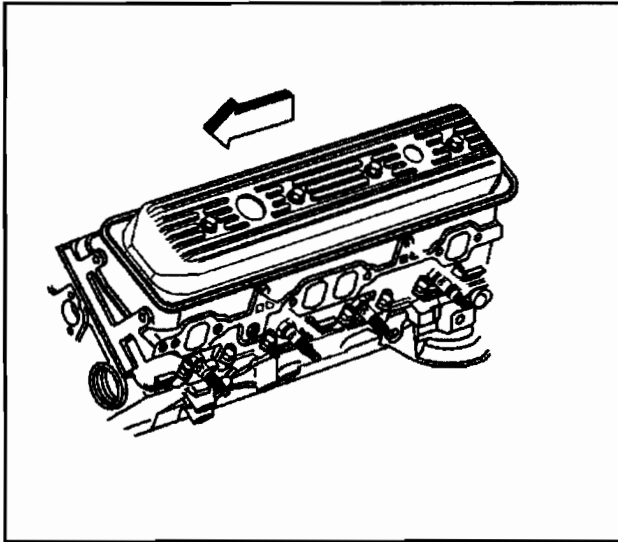
5. Install the exhaust manifold bolts.

Tighten

- 5.1. Tighten the exhaust manifold bolts on the first pass to 15 N·m (11 lb ft).
- 5.2. Tighten the exhaust manifold bolts on the final pass to 30 N·m (22 lb ft).



64925



317185

6. Install the spark plug wire supports and bolts.

Tighten

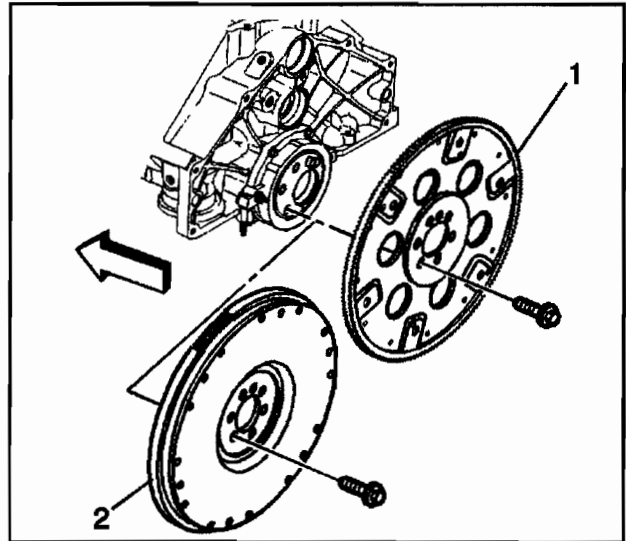
Tighten the bolts to 12 N·m (106 lb in).

7. Install the spark plug wires onto the spark plugs.

Engine Flywheel Installation

SIE-ID = 784241

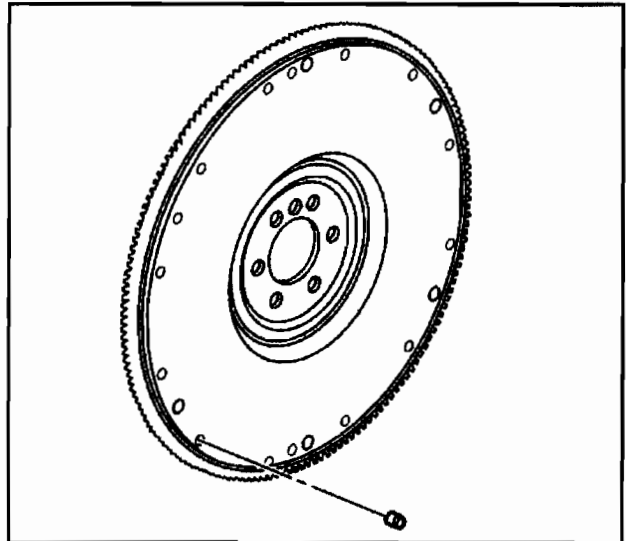
1. Install the engine flywheel (1 or 2) to the crankshaft.
Align the engine flywheel locator hole to the flywheel locator pin.



188129

Important: If replacing the engine flywheel (manual transmission), note the position and length of the original flywheel weights, if applicable. Flywheel weights of the same length must be installed into the new engine flywheel in the same location as the flywheel weights were in the old engine flywheel.

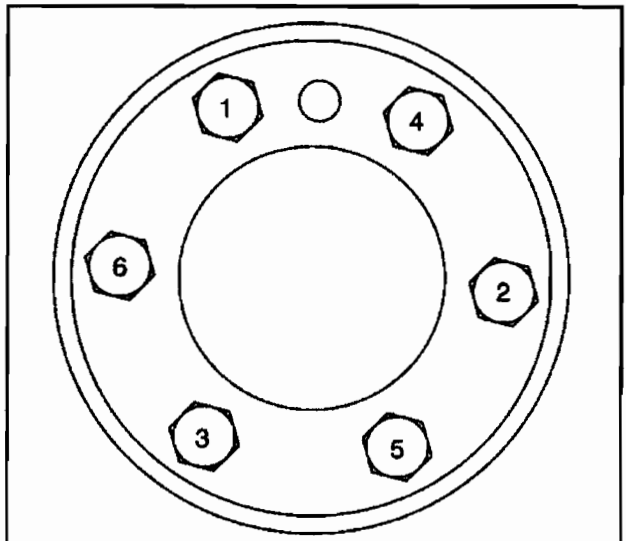
2. Note the position of the flywheel weights and install the NEW flywheel weights as required.
A properly installed flywheel weight will be flush or slightly below flush with the face of the engine flywheel.



64126

Notice: Refer to *Fastener Notice* in Cautions and Notices.

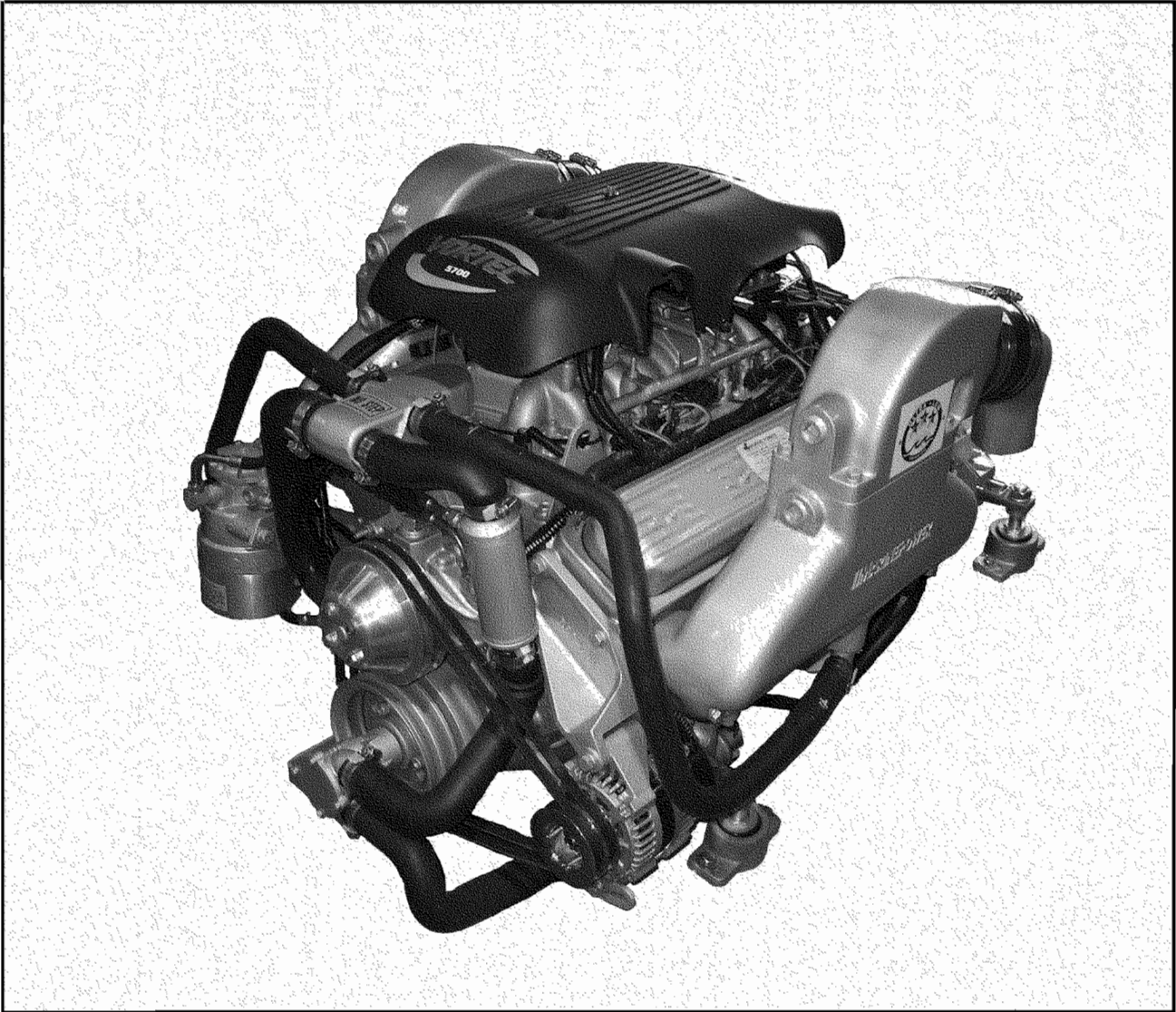
3. Install the engine flywheel bolts.
Tighten
Tighten the engine flywheel bolts in sequence (1-6) to 100 N·m (74 lb ft).



63174

Description and Operation

Engine Component Description



Cylinder Block

The engine block is made of cast iron and has eight cylinders arranged in a V shape with four cylinders in each bank. The cylinder block is a one piece casting with the cylinders encircled by coolant jackets.

Cylinder Head

The cylinder heads are made of cast iron. The valve guides and valve seats are machined surfaces integral to the cylinder head. The 5.7L heavy duty applications have pressed in exhaust valve seats. The spark plugs are located between the intake and exhaust ports.

Camshaft

A steel engine camshaft is supported by five camshaft bearings pressed into the engine block. The camshaft sprocket, mounted to the front of the engine camshaft, is driven by the crankshaft sprocket through a camshaft timing chain.

Motion from the engine camshaft is transmitted to the valves by hydraulic roller valve lifters, valve pushrods, and ball-pivot type valve rocker arms.

Crankshaft

The crankshaft is made of cast nodular iron. The crankshaft is supported by five crankshaft bearings. The crankshaft bearings are retained by the crankshaft bearing caps, which are machined with the engine block for proper alignment and clearances. Light duty

5.0L and 5.7L engines have two bolts per crankshaft bearing cap. The heavy duty 5.7L engines have four bolts per crankshaft bearing cap, on bearing caps 2, 3, and 4. The number 5 crankshaft bearing cap at the rear of the engine is the end thrust bearing cap. The four connecting rod journals (two connecting rods per journal) are spaced 90 degrees apart. The crankshaft position sensor reluctor ring is pushed onto the front of the crankshaft. The crankshaft position sensor reluctor ring has four lugs used for crankshaft timing and it is constructed of powdered metal. The reluctor ring has an interference fit onto the crankshaft and an internal keyway for correct positioning.

Pistons and Connecting Rods

The pistons are made of cast aluminum that use two compression rings and one oil control ring assembly. The piston is a low-friction, lightweight design with a flat top and barrel-shaped skirt. The piston pins are chromium steel. The piston pins have a floating fit in the piston and are retained by a press fit in the connecting rod assembly. The connecting rods are made out of either forged powdered metal or forged steel. The connecting rods are machined with the connecting rod cap installed for proper clearances and alignment.

Valve Train

The valve train is a ball pivot type. Motion is transmitted from the camshaft through the hydraulic roller valve lifters and tubular valve pushrods to the valve rocker arms. The valve rocker arm pivots on a ball in order to open the valve. The hydraulic roller valve lifters keep all parts of the valve train in constant contact. The valve rocker arm ball is retained on the valve rocker arm ball stud with a locking nut. The valve rocker arm ball studs are pressed into the cylinder head.

Intake Manifold

The intake manifold is a two piece design. The upper intake manifold portion is made from a composite material and the lower intake manifold portion is cast-aluminum. The throttle body mounts to the upper intake manifold. The lower intake manifold has an exhaust gas recirculation (EGR) port cast into the manifold for mixture of exhaust gases with the fuel and air mixture. The EGR valve mounts to the lower intake manifold.

The Central Sequential Multiport Fuel Injection, Central (SFI) system uses multiple injectors to meter and distribute fuel to each engine cylinder. The Central (SFI) unit is retained by a bracket bolted to the lower intake manifold. The TBI fuel meter also houses the pressure regulator. Metal inlet and outlet

fuel lines and nylon delivery tubes independently distribute fuel to each cylinder through nozzles located at the port entrance of each manifold runner where the fuel is atomized.

New Product Information

SIE-ID = 512775

The purpose of New Product Information is to highlight or indicate important product changes from the previous model year.

Changes may include one or more of the following items:

- Torque values and/or fastener tightening strategies
- Changed engine specifications
- New sealants and/or adhesives
- Disassembly and assembly procedure revisions
- Engine mechanical diagnostic procedure revisions
- New special tools required
- A component comparison from the previous year

Torque Values and/or Fastener Tightening Strategies

- Cylinder head bolts, crankshaft bearing cap bolts, and connecting rod bolts apply a torque angle strategy.

In an on-vehicle situation where a torque angle meter may not fit into the vehicle packaging, a three step tightening process may be used with a torque wrench.

- Certain fasteners should not be reused. Bolts, studs, or other fasteners that must be replaced will be called out in the specific service procedure.

Changed Engine Specifications

Engine specifications remain the same as the 1999 products.

Disassembly and Assembly Procedure Revisions and Additions

No revisions or additions.

Engine Mechanical Diagnostic Procedure Revisions

- Valve Train diagnostic information is now provided in table form. Potential or probable causes are supplied for each specific concern.
- Engine Noise diagnostic information is now provided in table form. Potential or probable causes are supplied for each specific concern.

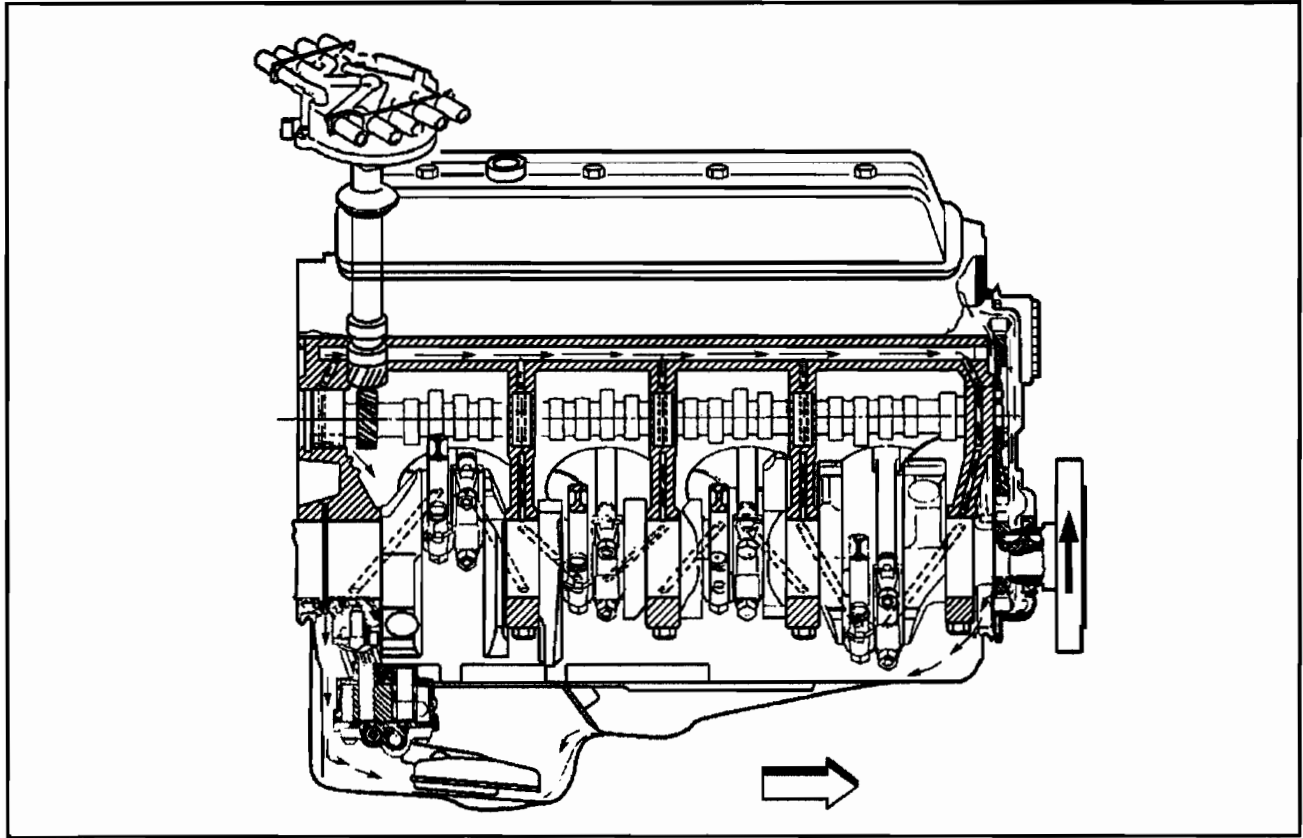
New Special Tools Required

No new special tools are required.

Lubrication Description

SIE-ID = 650073

Right Side View SIO-ID = 71039

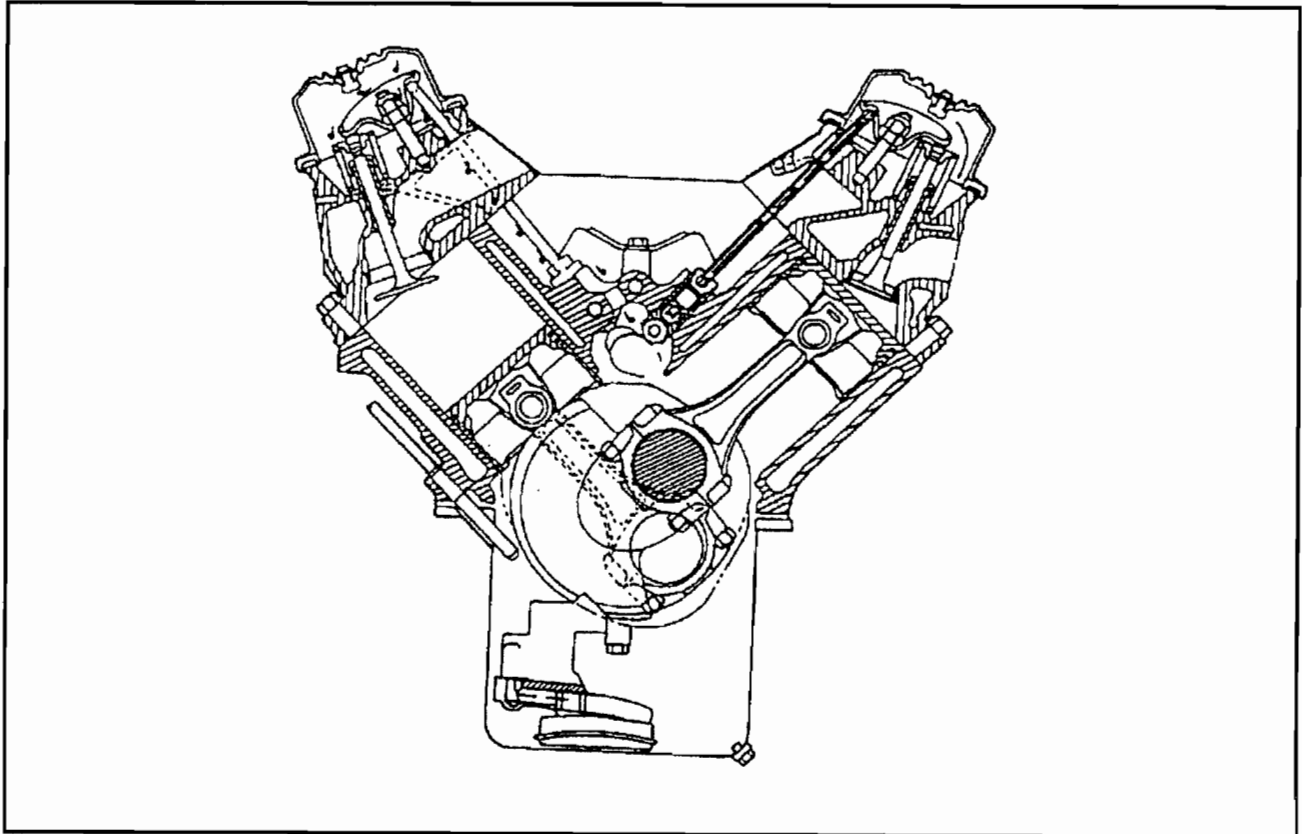


67757

The gear-type oil pump is driven through an extension driveshaft. The extension driveshaft is driven by the distributor which is gear driven by the camshaft. The oil is drawn from the oil pan through a pickup screen and tube. Pressurized oil is delivered through internal passages in order to lubricate the camshaft and the crankshaft bearings and to provide lash control in

the hydraulic valve lifters. Oil is metered from the valve lifters through the valve pushrods in order to lubricate the valve rocker arms and valve rocker arm ball pivots. Oil returning to the oil pan from the cylinder heads and the camshaft front bearing, lubricates the camshaft timing chain and the crankshaft and the camshaft sprockets.

Front View SIO-ID = 71037



67753

Cleanliness and Care

SIE-ID = 19007

- Throughout this section, it should be understood that proper cleaning and protection of machined surfaces and friction areas is part of the repair procedure. This is considered standard shop practice even if not specifically stated.
- When any internal engine parts are serviced, care and cleanliness is important.
- When components are removed for service, the components should be marked, organized or retained in a specific order for re-assembly.
- At the time of installation, the components should be installed in the same location and with the same mating surface as when removed.
- An automobile engine is a combination of many machined, honed, polished and lapped surfaces with tolerances that are measured in millimeters or thousandths of an inch. The surfaces should be protected to avoid component damage.
- Apply a liberal amount of clean engine oil to friction areas during assembly.
- Proper lubrication will protect and lubricate friction areas during initial operation.

Replacing Engine Gaskets

SIE-ID = 66654

2002 - Unit Repair (May 25, 2001)

Gasket Reuse and Applying Sealant

- Do not reuse any gasket unless specified.
- Gaskets that can be reused will be identified in the service procedure.
- Do not apply sealant to any gasket or sealing surface unless specified in the service procedure.

Separating Components

- Use a rubber mallet in order to separate the components.
- Bump the part sideways in order to loosen the components.
- Bumping of the component should be done at bends or reinforced areas of the component to prevent distortion of the components.

Cleaning Gasket Surfaces

- Use care to avoid gouging or scraping the sealing surfaces.
- Use a plastic or wood scraper in order to remove all the sealant from the components.
Do not use any other method or technique to remove the sealant or the gasket material from a part.
- Do not use abrasive pads, sand paper, or power tools to clean the gasket surfaces.
 - These methods of cleaning can cause damage to the component sealing surfaces.

- Abrasive pads also produce a fine grit that the oil filter cannot remove from the engine oil.

This fine grit is an abrasive and can cause internal engine damage.

Assembling Components

- Assemble components using only the sealant (or equivalent) that is specified in the service procedure.
- Sealing surfaces must be clean and free of debris or oil.
- Specific components such as crankshaft oil seals or valve stem oil seals may require lubrication during assembly.
- Components requiring lubrication will be identified in the service procedure.
- Apply only the amount of sealant specified in the service procedure to a component.
- Do not allow the sealant to enter into any blind threaded holes, as the sealant may prevent the fastener from clamping properly or cause component damage when tightened.

Important: Do not overtighten the fasteners.

- Tighten the fasteners to the proper specifications.

Use of RTV and Anaerobic Sealer

SIE-ID = 411537

Sealant Types

Important: The correct sealant and amount of sealant must be used in the proper location to prevent oil leaks, coolant leaks, or the loosening of the fasteners. DO NOT interchange the sealants. Use only the sealant, or equivalent, as specified in the service procedure.

The following 2 major types of sealant are commonly used in engines:

- Aerobic sealant Room Temperature Vulcanizing (RTV)
 - Gasket eliminator
 - Pipe
 - Threadlock

Aerobic Type Room Temperature Vulcanizing (RTV) Sealant

Aerobic type Room Temperature Vulcanizing (RTV) sealant cures when exposed to air. This type of sealant is used where 2 components, such as the intake manifold and the engine block, are assembled together.

Use the following information when using RTV sealant:

- Do not use RTV sealant in areas where extreme temperatures are expected. These areas include:
 - The exhaust manifold
 - The head gasket

- Any other surfaces where a different type of sealant is specified in the service procedure

- Always follow all the safety recommendations and the directions that are on the RTV sealant container.
- Use a plastic or wood scraper in order to remove all the RTV sealant from the components.

Notice: SIO-ID = 68592 Do not allow the RTV sealant to enter any blind threaded hole. RTV sealant that is allowed to enter a blind threaded hole can cause hydraulic lock of the fastener when the fastener is tightened. Hydraulic lock of a fastener can lead to damage to the fastener and/or the components. Hydraulic lock of a fastener can also prevent the proper clamping loads to be obtained when the fastener is tightened. Improper clamping loads can prevent proper sealing of the components allowing leakage to occur. Preventing proper fastener tightening can allow the components to loosen or separate leading to extensive engine damage.

- The surfaces to be sealed must be clean and dry.
- Use a RTV sealant bead size as specified in the service procedure.
- Apply the RTV sealant bead to the inside of any bolt holes areas.

Important: Do not wait for the RTV sealant to skin over.

- Assemble the components while the RTV sealant is still wet to the touch, within 3 minutes.

Important: Do not overtighten the fasteners.

- Tighten the fasteners in sequence, if specified, and to the proper torque specifications.

Anaerobic Type Gasket Eliminator Sealant

Anaerobic type gasket eliminator sealant cures in the absence of air. This type of sealant is used where 2 rigid parts, such as castings, are assembled together. When 2 rigid parts are disassembled and no sealant or gasket is readily noticeable, then the 2 parts were probably assembled using an anaerobic type gasket eliminator sealant.

Use the following information when using gasket eliminator sealant:

- Always follow all the safety recommendations and directions that are on the gasket eliminator sealant container.
- Apply a continuous bead of gasket eliminator sealant to one flange.
 - The surfaces to be sealed must be clean and dry.

Important:

- Do not allow the gasket eliminator sealant to enter any blind threaded holes, as the gasket eliminator sealant may prevent the fasteners from clamping properly, seating properly, or cause damage when the fastener tightened.
- Gasket eliminator sealed joint fasteners that are partially torqued and the gasket eliminator sealant allowed to cure more than five minutes, may result in incorrect shimming and sealing of the joint.

- Do not overtighten the fasteners.
 - Apply the gasket eliminator sealant evenly to get a uniform thickness of the gasket eliminator sealant on the sealing surface.
 - Tighten the fasteners in sequence, if specified, and to the proper torque specifications.
 - After properly tightening the fasteners, remove the excess gasket eliminator sealant from the outside of the joint.

Anaerobic Type Threadlock Sealant

Anaerobic type threadlock sealant cures in the absence of air. This type of sealant is used for threadlocking and sealing of bolts, fittings, nuts, and studs. This type of sealant cures only when confined between 2 close fitting metal surfaces.

Use the following information when using threadlock sealant:

- Always follow all safety recommendations and directions that are on the threadlock sealant container.
- The threaded surfaces to be sealed must be clean and dry.
- Apply the threadlock sealant as specified on the threadlock sealant container.

Important:

- Fasteners that are partially torqued and then the threadlock sealant allowed to cure more than five minutes, may result in incorrect clamp load of assembled components.
- Do not overtighten the fasteners.
- Tighten the fasteners in sequence, if specified, and to the proper torque specifications.

Anaerobic Type Pipe Sealant

Anaerobic type pipe sealant cures in the absence of air and remains pliable when cured. This type of sealant is used where 2 parts are assembled together and require a leak proof joint.

Use the following information when using pipe sealant:

- Do not use pipe sealant in areas where extreme temperatures are expected. These areas include:
 - The exhaust manifold
 - The head gasket
 - Surfaces where a different sealant is specified
- Always follow all the safety recommendations and the directions that are on the pipe sealant container.
- The surfaces to be sealed must be clean and dry.
- Use a pipe sealant bead of the size or quantity as specified in the service procedure.

Notice: S10-ID = 768432 Do not allow the pipe sealant to enter a blind hole. The pipe sealant may prevent the fastener from achieving proper clamp load, cause component damage when the fastener is tightened, or lead to component failure.

- Apply the pipe sealant bead to the inside of any bolt hole areas.
- Apply a continuous bead of pipe sealant to 1 sealing surface.

Important: Do not overtighten the fasteners.

- Tighten the fasteners in sequence, if specified, and to the proper torque specifications.

Separating Parts

S1E-ID = 194497

Important: Many internal engine components will develop specific wear patterns on their friction surfaces.

When disassembling the engine, internal components **MUST** be separated, marked and organized in a way to ensure reinstallation to original location and position.

Mark or identify the following components:

- Piston and the piston pin
- Piston to the specific cylinder bore
- Piston rings to the specific cylinder bore
- Connecting rod to the crankshaft journal
- Connecting rod to connecting rod cap
- Crankshaft bearings and connecting rod bearings
- Engine camshaft and valve lifters
- Valve lifters and valve rocker arms
- Valve to the valve guide
- Valve spring to cylinder head location
- Engine block bearing cap location and direction
- Oil pump drive and driven gears

Tools and Equipment

S1E-ID = 507215

Special tools are listed and illustrated throughout this section with a complete listing at the end of the section. The tools (or the equivalents) are specially designed to quickly and safely accomplish the operations for which the tools are intended. The use of special tools will also minimize possible damage to engine components. Some precision measuring tools are required for inspection of certain critical components. Torque wrenches and a torque angle meter are necessary for the proper tightening of various fasteners.

To properly service the engine assembly, the following items should be readily available:

- Approved eye protection and safety gloves
- A clean, well-lit, work area
- A suitable parts cleaning tank
- A compressed air supply
- Trays or storage containers to keep parts and fasteners organized
- An adequate set of hand tools
- Approved engine repair stand
- An approved engine lifting device that will adequately support the weight of the components

Special Tools and Equipment

SIE-ID = 690690


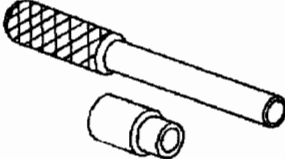
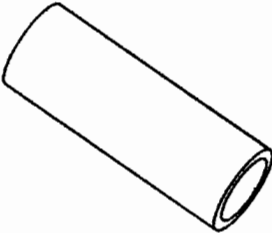
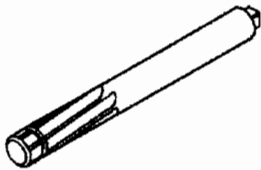
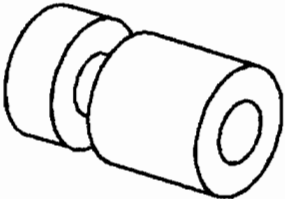
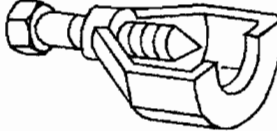
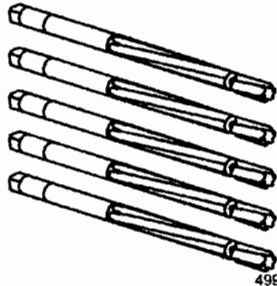
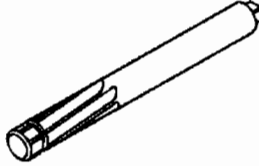
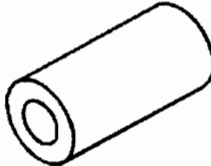
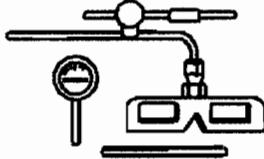
Illustration	Tool Number/ Description
 <p>14487</p>	<p>J 3049-A Valve Lifter Remover</p>
 <p>3404</p>	<p>J 5239 Connecting Rod Bolt Guide Set</p>
 <p>3407</p>	<p>J 5590 Installer</p>
 <p>69826</p>	<p>J 5715 Rocker Stud Hole Reamer 0.0762 mm (0.003 in) oversized</p>
 <p>35460</p>	<p>J 5802-01 Rocker Arm Stud Remover</p>

Illustration	Tool Number/ Description
 <p>3406</p>	<p>J 5825-A Crankshaft Gear Remover</p>
 <p>4999</p>	<p>J 5830-02 Valve Guide Reamer Set</p>
 <p>14492</p>	<p>J 6036 Rocker Stud Hole Reamer 0.33 mm (0.013 in) oversize</p>
 <p>35461</p>	<p>J 6880 Rocker Arm Stud Installer</p>
 <p>35463</p>	<p>J 7872 Magnetic Base Dial Indicator</p>

Engine

Engine Mechanical - 5.0L and 5.7L 6-147

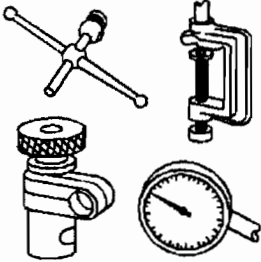
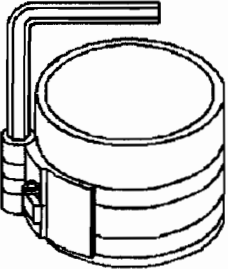
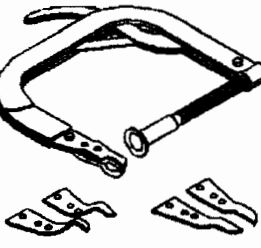
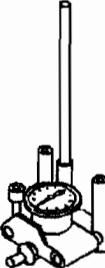
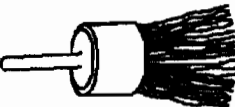
Illustration	Tool Number/ Description
 <p data-bbox="444 478 483 493">2014</p>	<p data-bbox="558 317 737 373">J 8001 Dial Indicator Set</p>
 <p data-bbox="444 787 483 802">3403</p>	<p data-bbox="558 625 737 682">J 8037 Ring Compressor</p>
 <p data-bbox="444 1096 483 1110">3414</p>	<p data-bbox="516 934 776 991">J 8062 Valve Spring Compressor</p>
 <p data-bbox="444 1404 483 1419">5110</p>	<p data-bbox="542 1243 750 1299">J 8087 Cylinder Bore Gage</p>
 <p data-bbox="435 1711 483 1726">35464</p>	<p data-bbox="516 1554 769 1610">J 8089 Carbon Removing Brush</p>

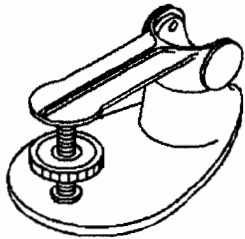


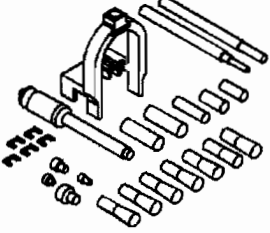
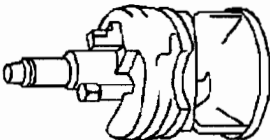
Illustration	Tool Number/ Description
 <p data-bbox="1127 478 1166 493">5112</p>	<p data-bbox="1224 317 1432 373">J 9666 Valve Spring Tester</p>
 <p data-bbox="1127 787 1166 802">3416</p>	<p data-bbox="1198 625 1451 682">J 21882 Oil Suction Pipe Installer</p>
 <p data-bbox="1110 1096 1149 1110">66188</p>	<p data-bbox="1208 924 1442 1001">J 23523-F Balancer Remover and Installer</p>
 <p data-bbox="1110 1404 1149 1419">14485</p>	<p data-bbox="1214 1234 1435 1312">J 24086-C Piston Pin Remover/Installer Set</p>
 <p data-bbox="1110 1711 1149 1726">3412</p>	<p data-bbox="1175 1554 1468 1610">J 24270 Cylinder Bore Ridge Reamer</p>

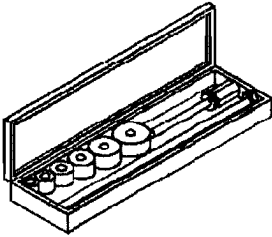
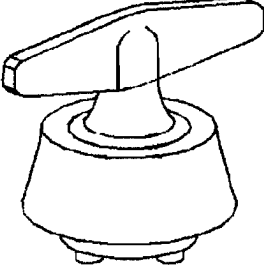
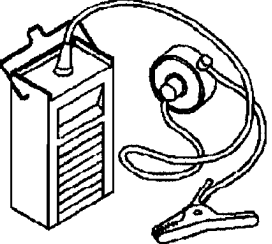
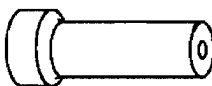
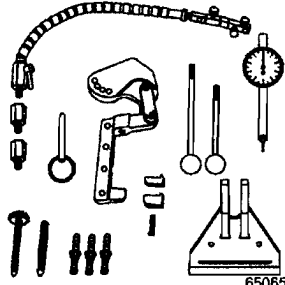
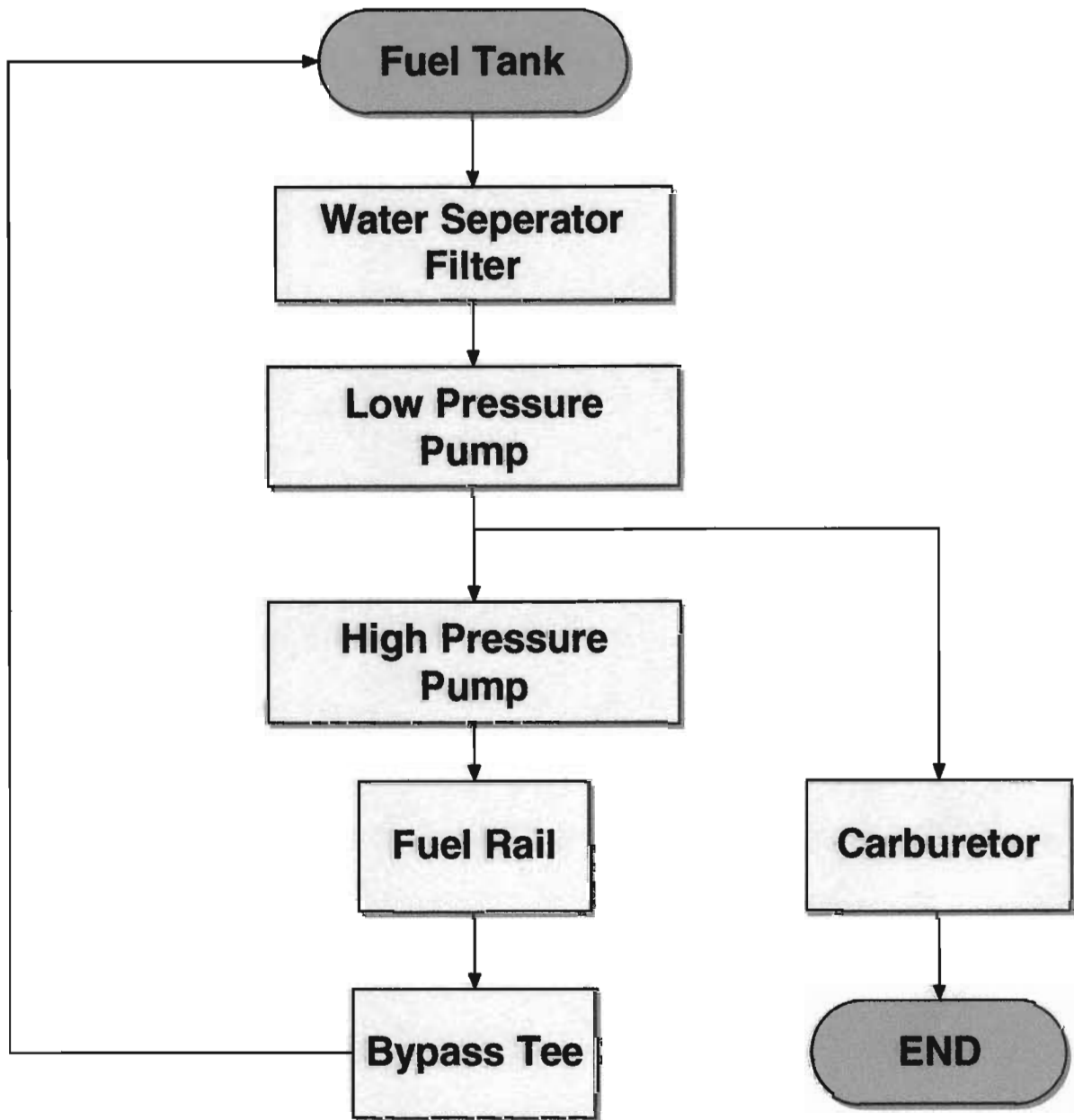
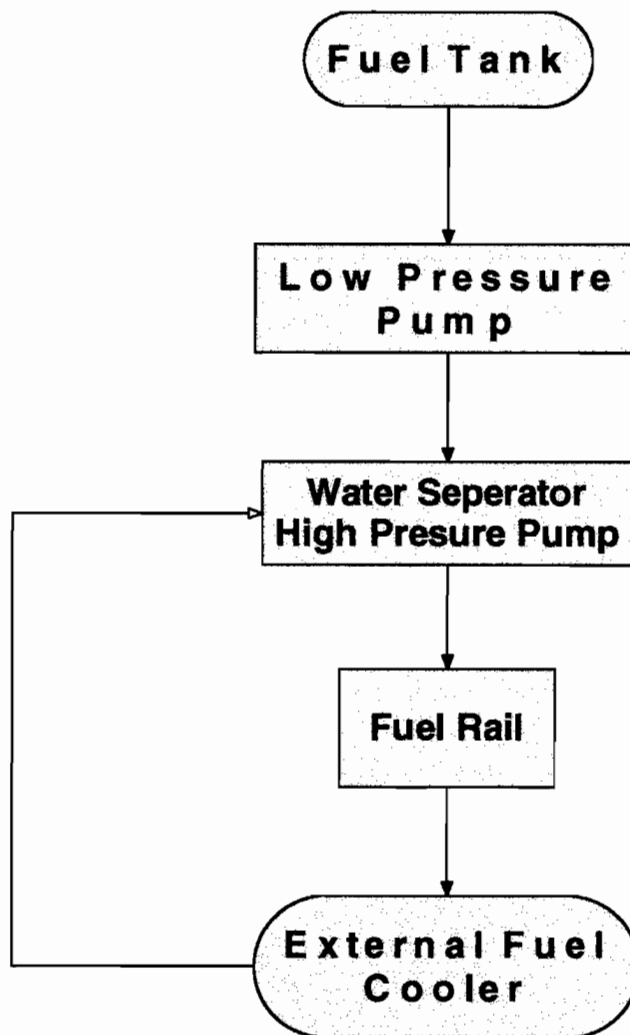
Illustration	Tool Number/ Description
 <p style="text-align: right;">5118</p>	<p>J 33049 Camshaft Bearing Service Set</p>
 <p style="text-align: right;">350498</p>	<p>J 35621-B Rear Main Seal Installer</p>
 <p style="text-align: right;">3413</p>	<p>J 36660-A Electronic Torque Angle Meter</p>

Illustration	Tool Number/ Description
 <p style="text-align: right;">38509</p>	<p>J 42073 Valve Stem Seal Installer</p>
 <p style="text-align: right;">650651</p>	<p>J 43690 Rod Bearing Clearance Checking Tool</p>

Fuel System



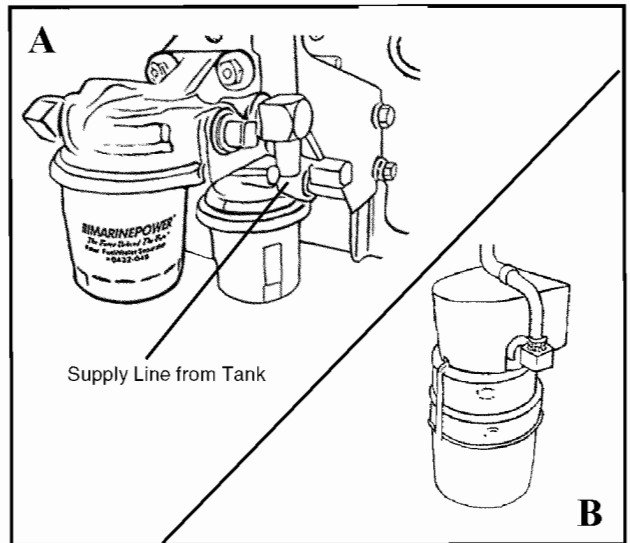
G-Force Fuel System



Fuel System Components

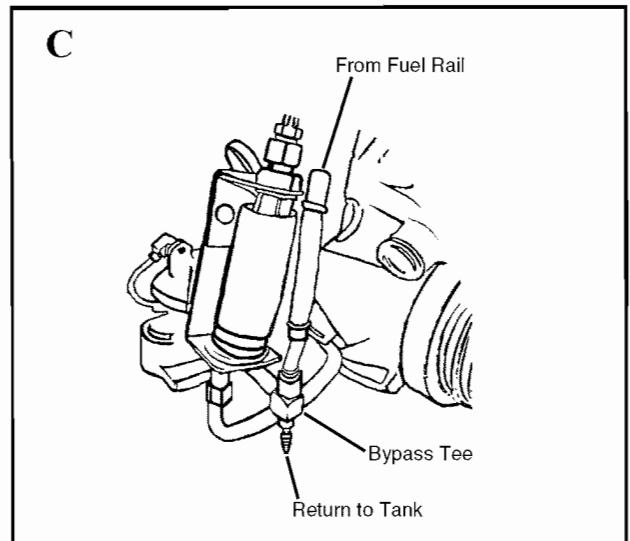
- A. Regular fuel filter, water separator, and pump
- B. G-Force fuel pump / water separator system

NOTE: Small Block uses 3/8" supply line
 Large Block uses 1/2" supply line

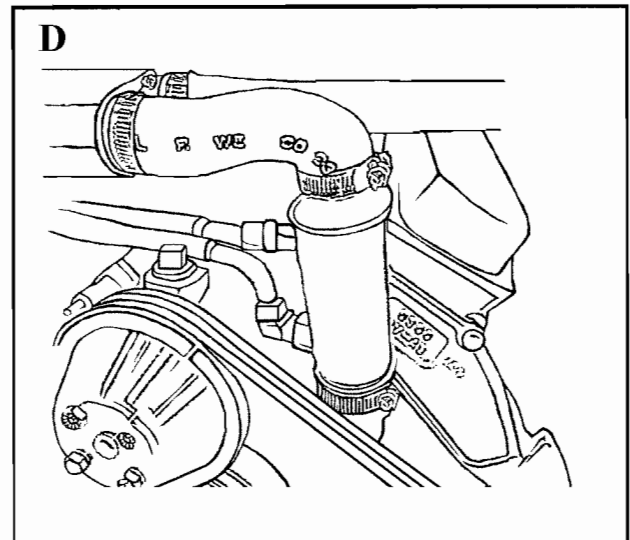


- C. High Pressure Pump

NOTE: Bypass Tee must Return to Tank



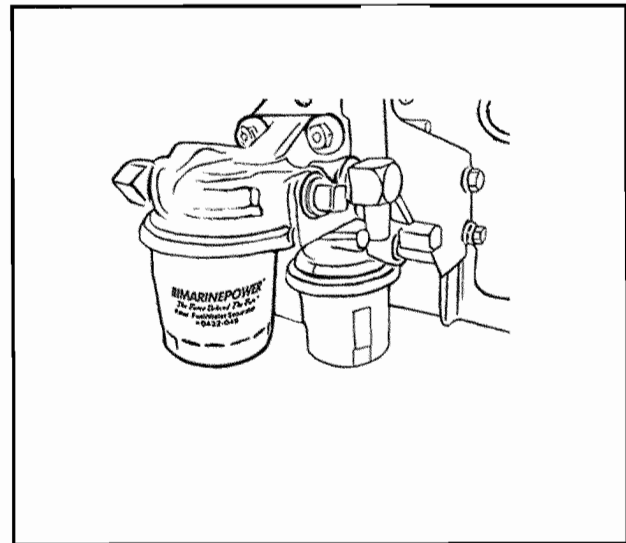
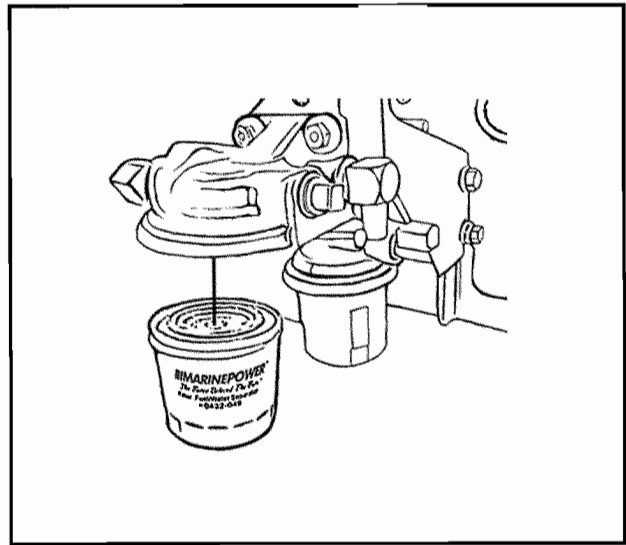
- D. Fuel Cooler
 (Only on Returnless G-Force System)



Fuel System

Fuel Filter Removal and Installation

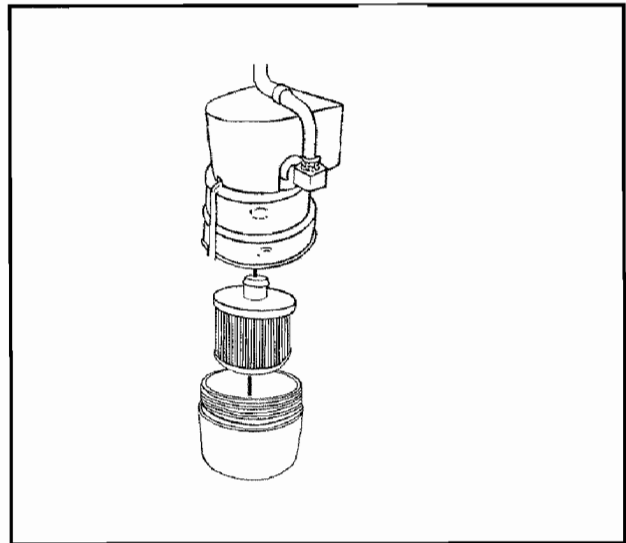
1. Disconnect battery terminals starting with negative side first.
2. Turn off fuel from tank.
3. Unscrew fuel filter
4. Discard fuel filter
5. Lubricate the o-ring on the new filter
6. Fill filter 2/3 full with fuel before reinstalling
7. Install the new filter by screwing it in hand tight plus $\frac{1}{2}$ turn.
8. Reconnect battery terminals starting with the positive side
9. Turn on the fuel from tank



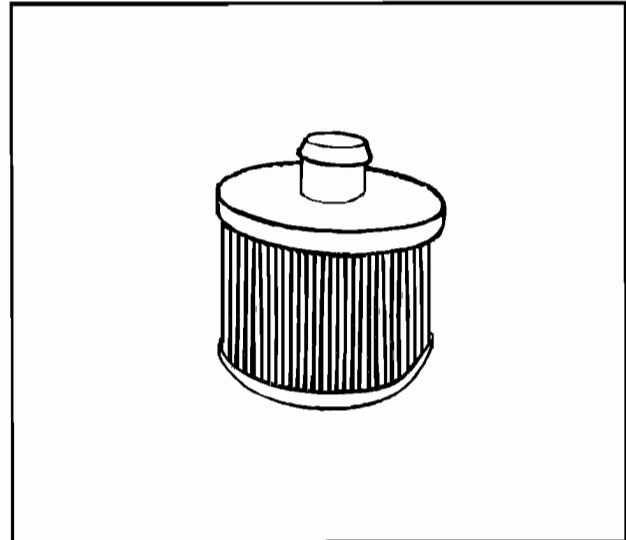
G-Force Fuel System

Fuel Filter Removal and Installation

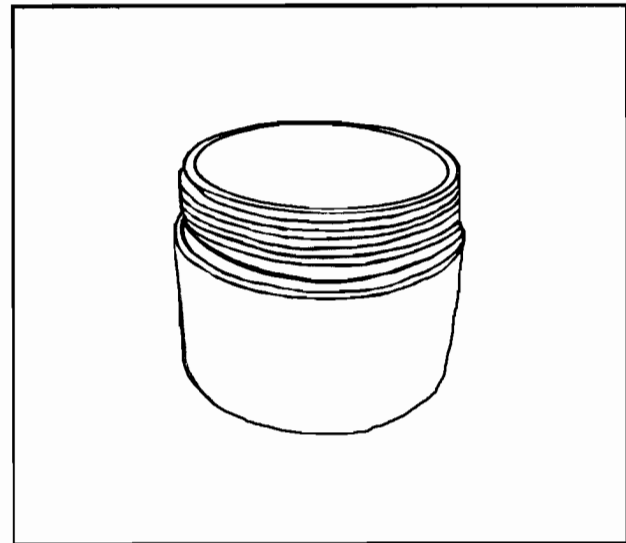
1. Disconnect the battery terminals starting with the negative side.
2. Close the fuel valve at tank
3. Drain bowl by removing drain plug
4. Replace drain plug
5. Using a strap wrench unscrew bowl.



6. Remove and discard o-ring and the filter
7. Replace the old filter with a new filter
8. Lubricate the new o-ring and place it over bowl threads

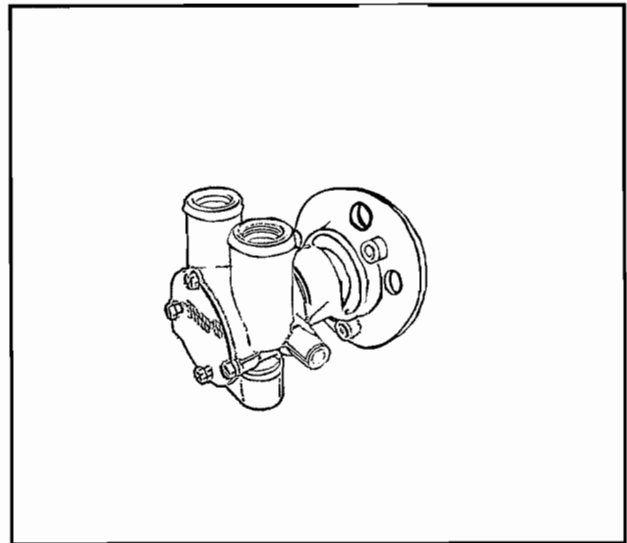


9. Fill the bowl 2/3 full with fuel
10. Install the bowl (use strap wrench if necessary)
11. Tighten with strap wrench
12. Reconnect battery terminals starting with the positive side
13. Turn on the fuel from tank

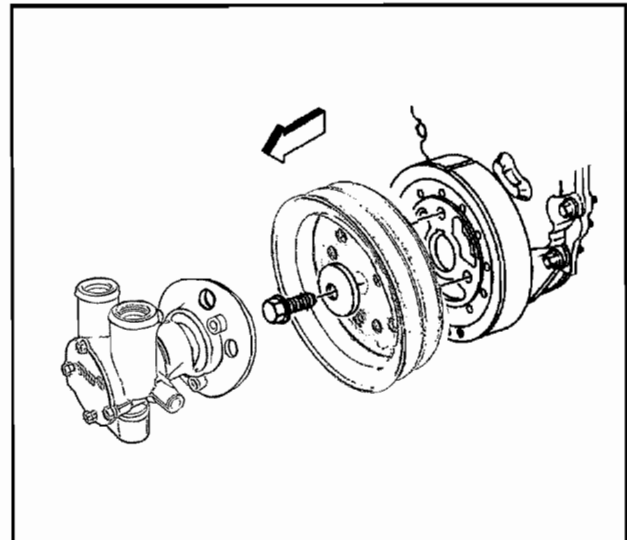


Seawater Pump Installation

1. Insert dampener bolt and washer into crank pulley.
2. Place crank pulley, bolt, and washer into the dampener, then tighten by hand two turns. Do Not Tighten snug



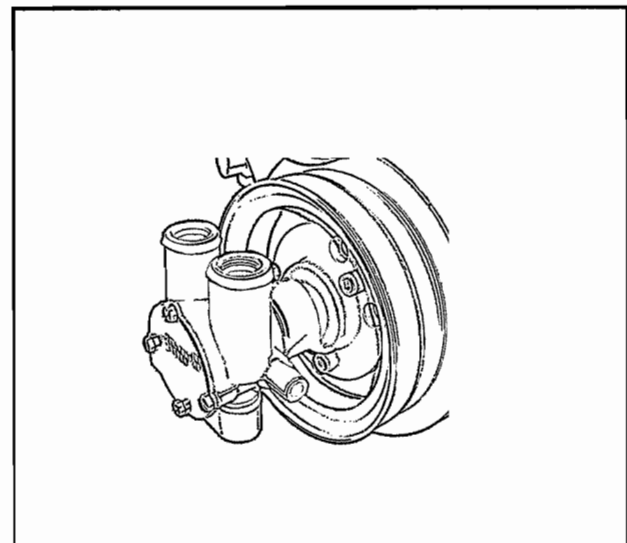
3. Using the three seawater pump bolts, align the crank pulley to the balancer. NOTE: Do Not Tighten These Bolts.
4. Once the crank pulley is aligned, tighten the crank pulley bolt.
5. Remove the three seawater bump bolts.
6. Line up the three large diameter holes on the seawater pump with the crank pulley.



IMPORTANT: Be sure that not only the bolt holes are aligned but also the pump must be flush against the crank pulley.

CAUTION: If the pump is not flush against the crank pulley before tightening the pump will be damaged.

7. Once the pump is properly aligned, install the three seawater pump bolts.
8. Tighten the three bolts.



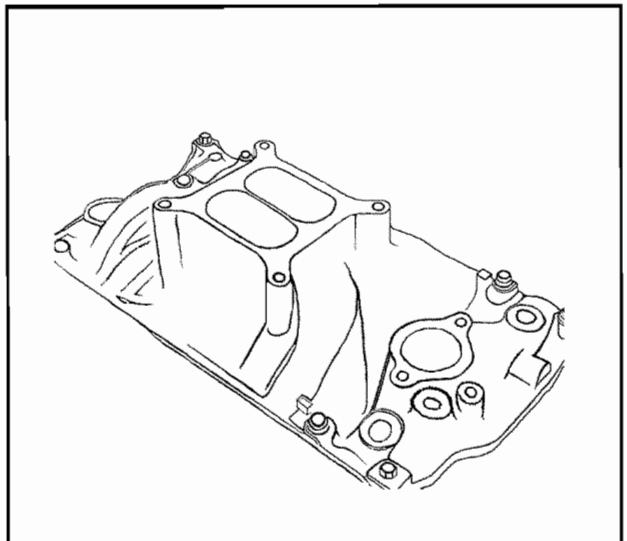
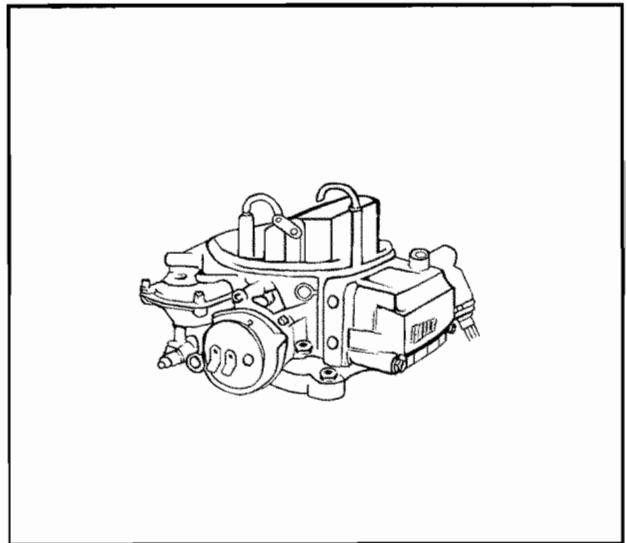
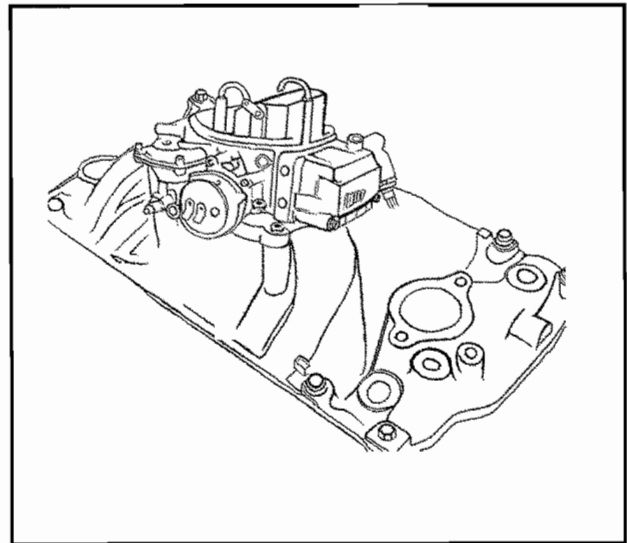
Carburetor Removal

Dirt, water, and debris inside the carburetor are the main cause of carburetor malfunctions. In order to properly diagnose the problem, the carburetor must be removed without draining the fuel from the bowl. In doing this, the bowl and its contents may be inspected.

1. Disconnect the battery terminals starting with the negative terminal.
2. Turn off fuel supply
3. Remove the weather cover, ventilation hoses, and flame arrestor.
4. Disconnect the electric choke wires from their terminals.
5. Disconnect the throttle cable from the anchor stud and the bracket.
6. Remove the throttle cable.
7. Remove the fuel line
8. Unbolt and remove the carburetor from the intake Manifold.
9. Remove wedge plate (if applicable)
10. Remove gasket
11. Clean carburetor base, wedge plate, and gasket surface of the intake manifold.

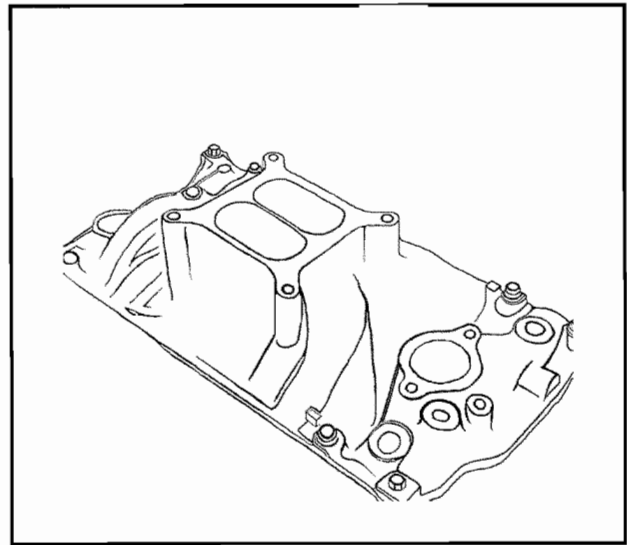
Caution

Be sure to place a clean cloth over the intake manifold opening to ensure that no foreign objects are subject to entry.

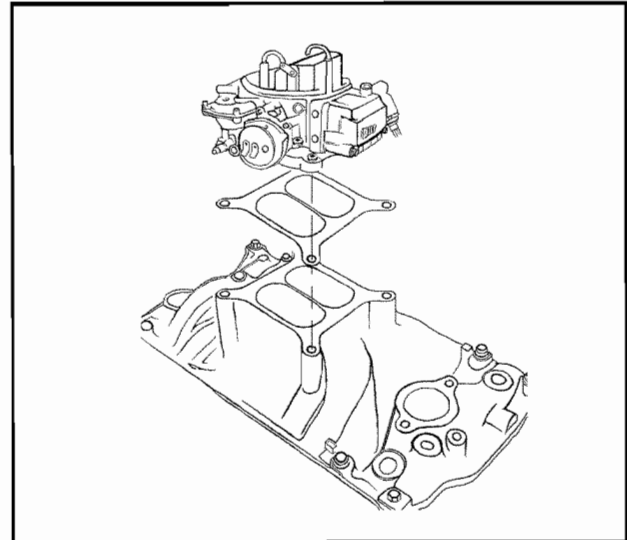


Carburetor Installation

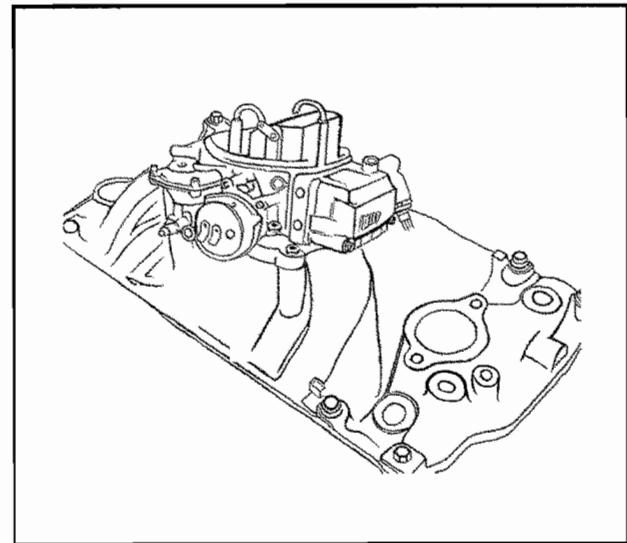
1. Place a new gasket onto the intake manifold.
2. Install the wedge plate (if equipped)



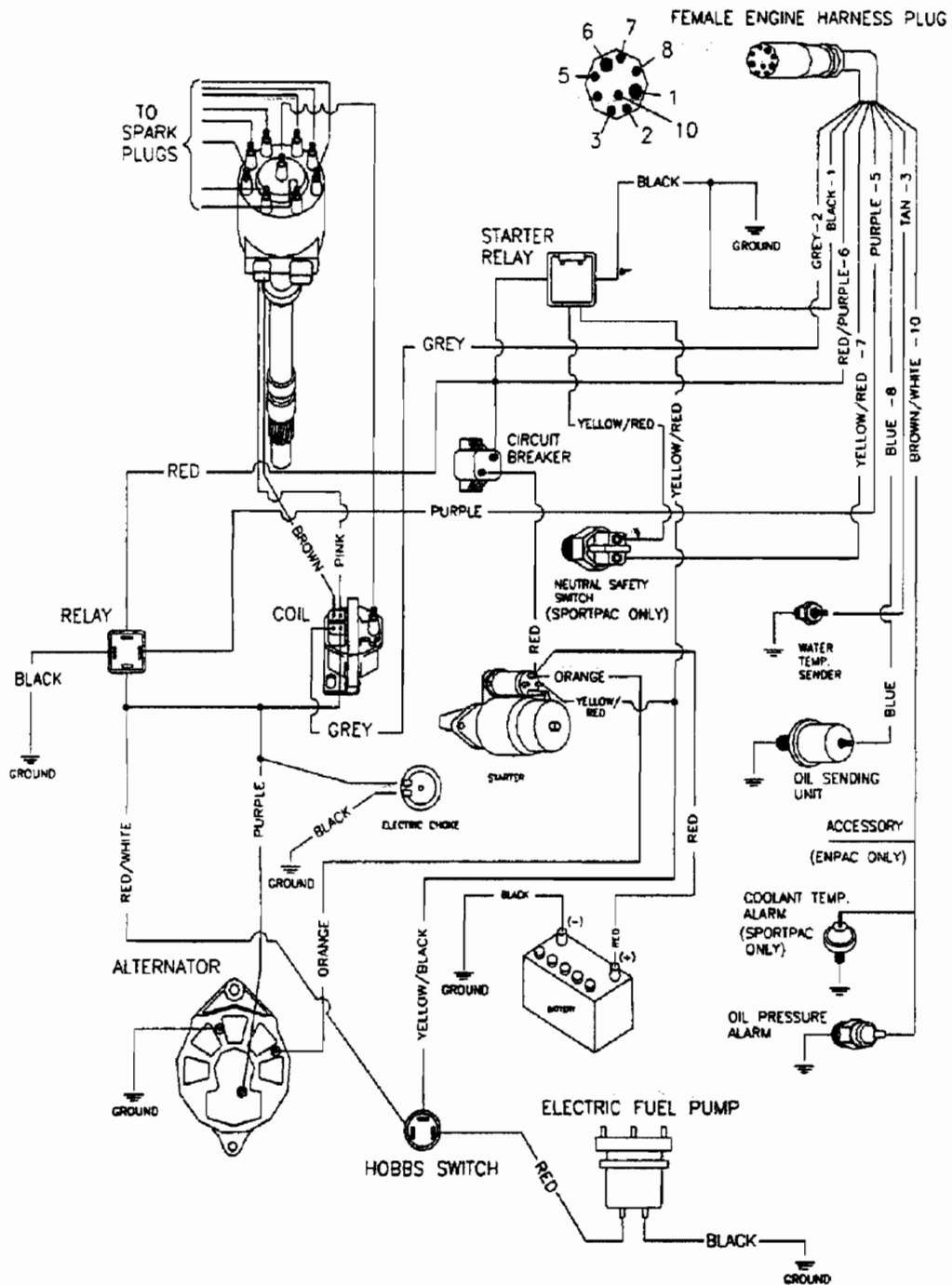
3. Install the carburetor and throttle bracket
4. Torque all studs to torque specs. (15 N-m or 132 lb. in.)
5. Connect the fuel line.
6. Attach the throttle cable
7. Attach the electric choke wires from their terminals.



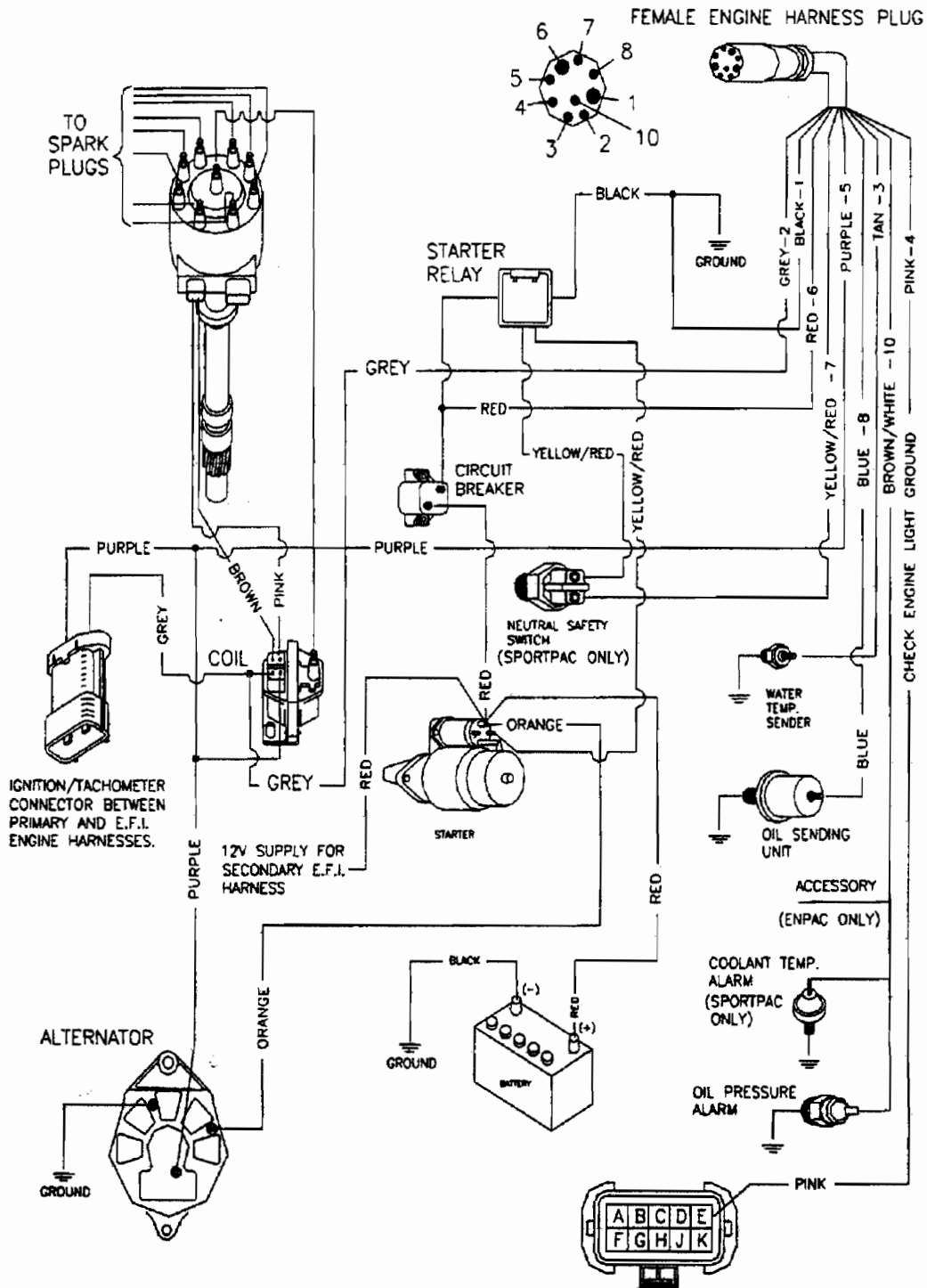
8. Install the flame arrestor and ventilation hoses.
9. Turn on fuel supply
10. Reconnect the battery terminals starting with the positive side first.
11. Start engine and check for gasoline leaks. If any leaks exist stop engine immediately and recheck connections.
12. Install the weather cover.



Carbureted Engine Harness

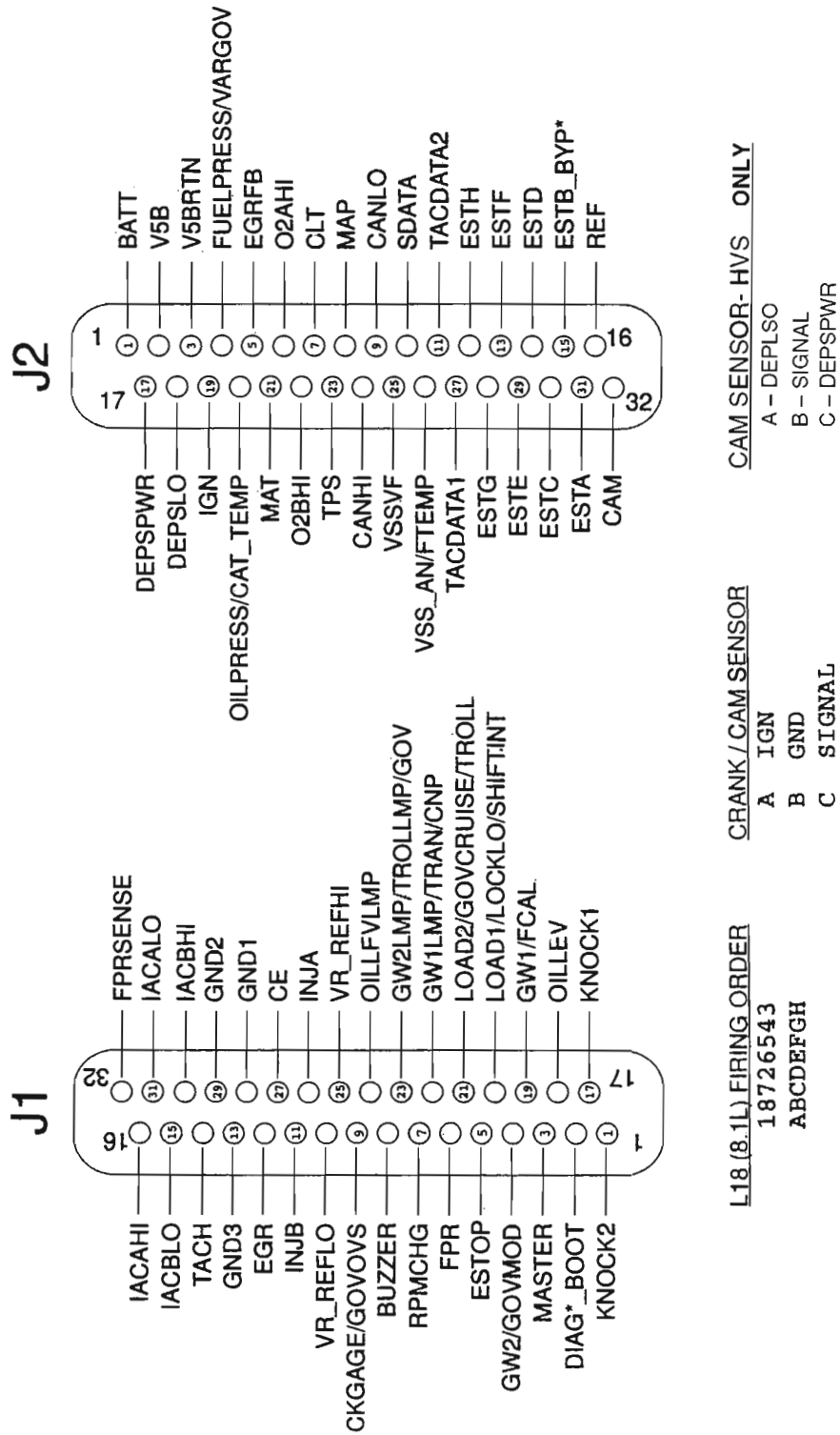


EFI Primary Engine Harness

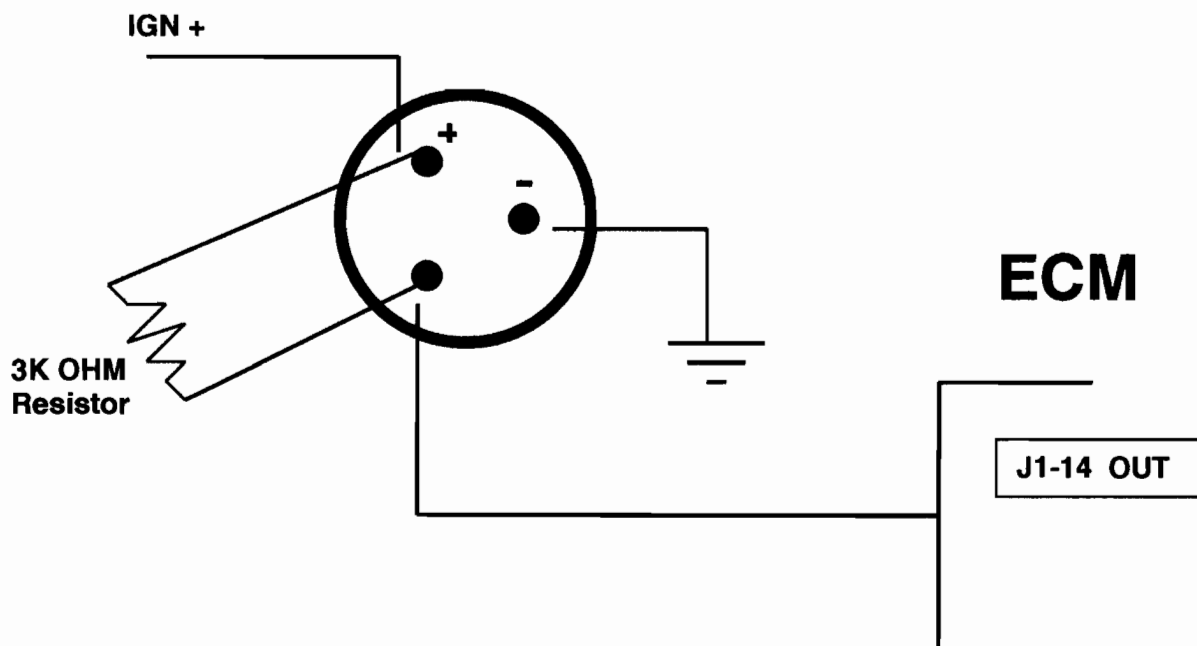


MEFI4 ECM Pinout

CONNECTORS AS VIEWED EXTERNAL TO MODULE



Tachometer

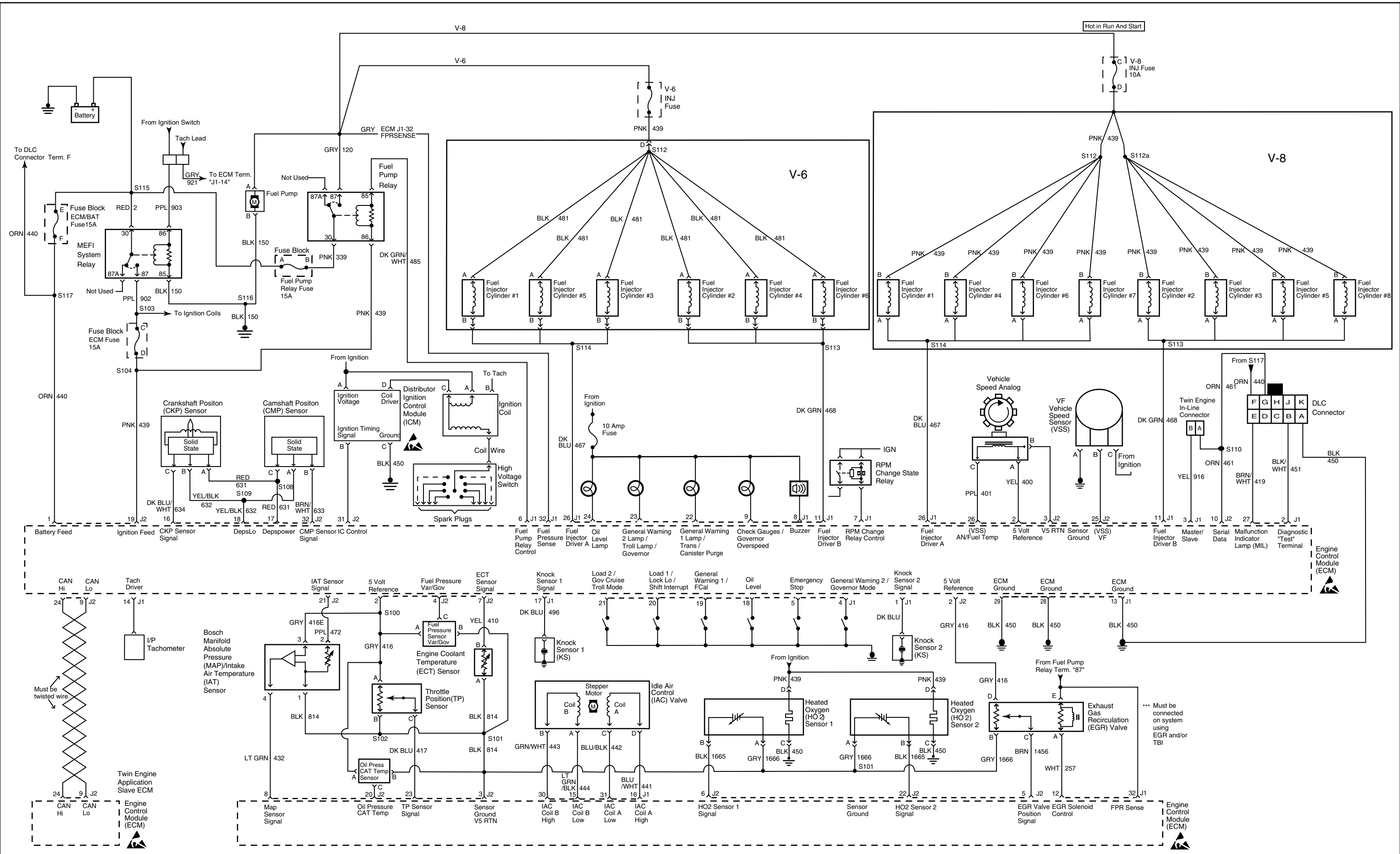


MEFI 4a required
Enable Bit 5 on syscfg 9

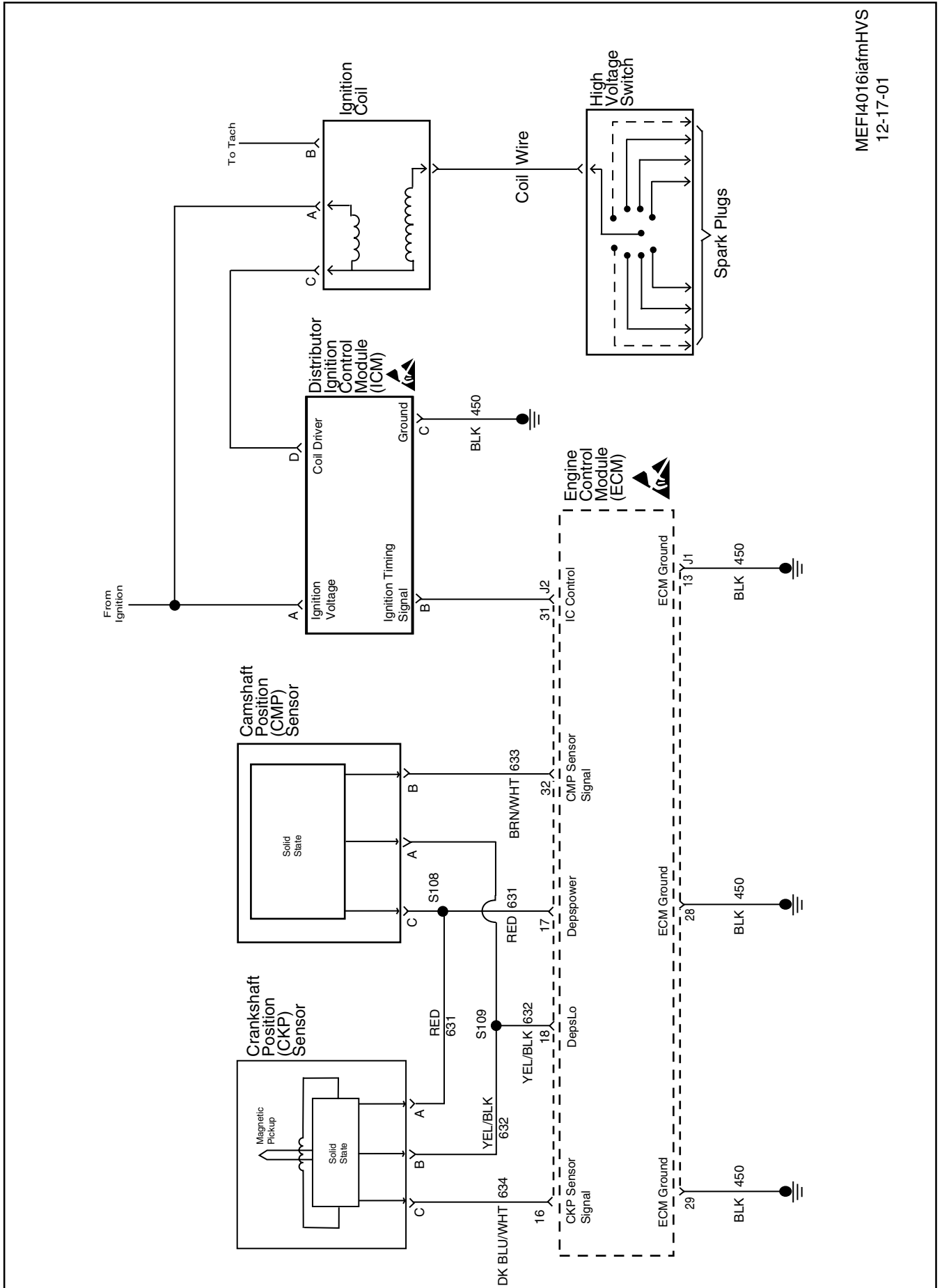
Wire Tach to J1 -12

Install 3K ohm pull up resistor from Ignition to positive (+) Tach signal (easy at back of Tach)

Configurable Tachometer signal screen
KCFGTACHA 1.0
KCFGTLTA .102



DTC 41 - Enhanced Ignition System



MEFI4016iatmHVS
12-17-01

DTC 41 - Enhanced Ignition System**Circuit Description**

The enhanced ignition system uses the crankshaft position (CKP) sensor in order to provide a timing input to the control module. Ignition control (IC) spark timing for each cylinder is based on this input. The engine control module provides the ignition timing signal to the ignition control module (ICM) to control the ignition coil. Each timing pulse detected by the ICM allows the ICM to energize the ignition coil. A large secondary ignition voltage is induced in the secondary coil by the primary coil. This high voltage is switched to the correct spark plug by the distributor. This diagnostic trouble code (DTC) will set if the Engine control module (ECM) detects an unusually high or low voltage on the ignition timing signal circuit.

Test Description

Number(s) below refer to the step number(s) on the diagnostic table:

2. This step determines if the DTC is an intermittent.
3. This step checks if the IC timing signal from the PCM is available at the ignition control module.

Step	Action	Value	Yes	No
1	Did you perform the On-Board Diagnostic (OBD) system check?	—	Go to Step 2	Go to OBD System Check
2	1. Clear the DTCs 2. Disconnect the injector harness connector. 3. Crank the engine for 15 seconds. Does DTC 41 set?	—	Go to Step 3	Go to Intermittent Conditions
3	1. Turn OFF the ignition. 2. Reconnect the injector harness connector. 3. Disconnect the ICM harness connector. 4. Probe the IC timing control circuit (PIN B) and a known good ground with a DMM set to the AC scale. 5. Crank the engine. 6. Observe the voltage. Does the voltage measure within the specified value?	1-4	Go to Step 4	Go to Step 6
4	1. Turn OFF the ignition. 2. Probe the IC ground circuit (PIN C) at the ICM connector with a test lamp connected to B+. Does the test lamp illuminate?	—	Go To Step 5	Go To Step 11
5	1. Turn ON the ignition, with the engine OFF. 2. Probe the ignition voltage circuit (PIN A) at the ICM harness connector with a test lamp connected to ground. Does the test lamp illuminate?	—	Go To Step 9	Go To Step 14
6	1. Turn OFF the ignition. 2. Disconnect the ECM connector J2. 3. Probe the IC timing control circuit (PIN 31) at the ECM connector with a test lamp connected to B+ Does the test lamp illuminate?	—	Go To Step 12	Go To Step 7

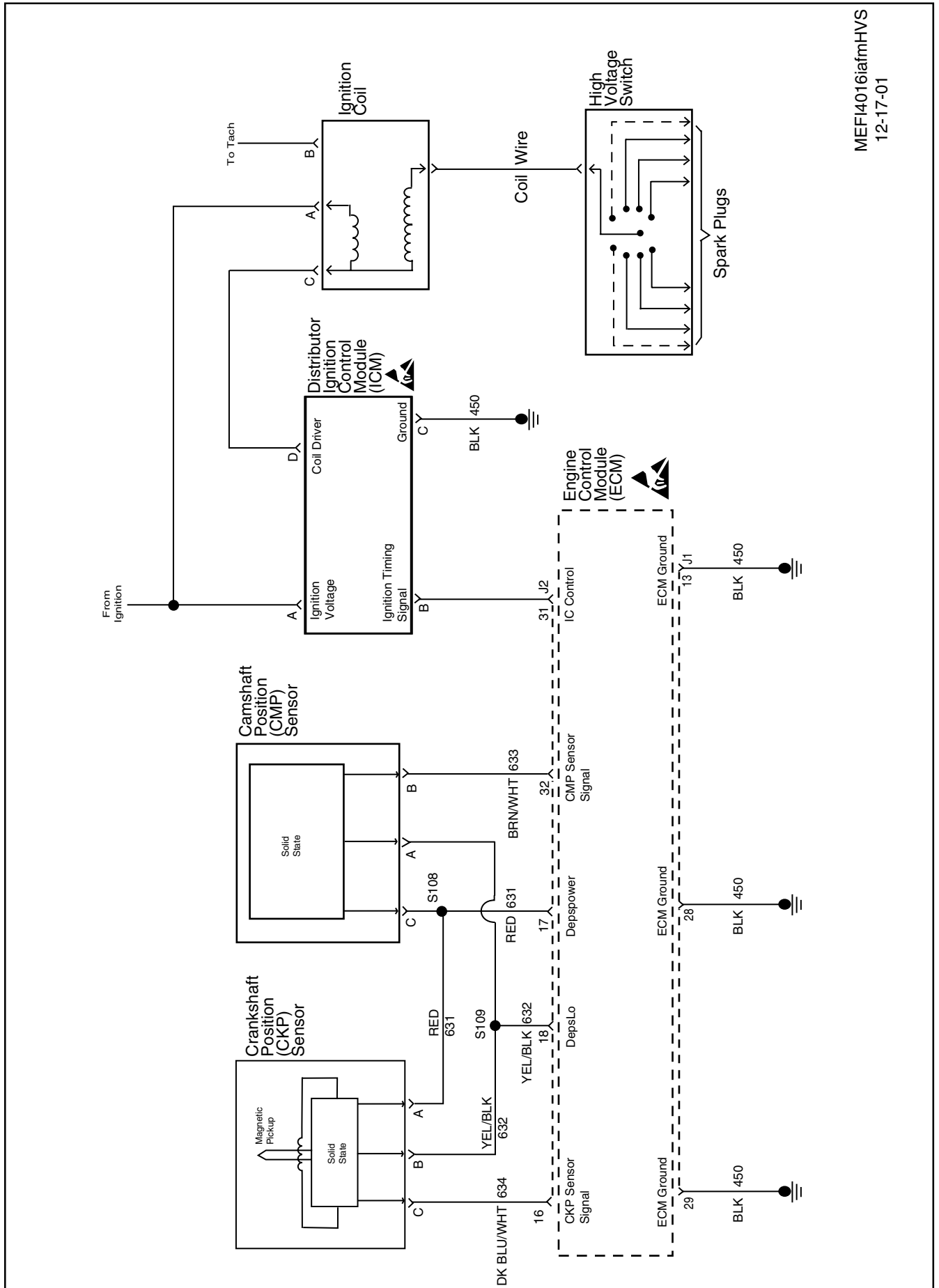
DTC 41 - Enhanced Ignition System (cont'd)

Step	Action	Value	Yes	No
7	1. Turn OFF the ignition. 2. Test for an open in the IC timing control circuit between the ECM and the ICM harness connector. Did you find and correct the condition?	—	Go to Step 17	Go To Step 8
8	1. Reconnect the ECM connector. 2. Turn ON the ignition, with the engine OFF. 3. Probe the IC timing control circuit (PIN B) at the ICM harness connector with a DMM set to the DC scale and connected to ground. Does the voltage measure more than the specified value?	1.0	Go To Step 13	Go To Step 10
9	1. Inspect for poor connections at the harness connector of the ICM. 2. Refer to Testing for Poor Connections. Did you find and correct the condition?	—	Go To Step 17	Go To Step 15
10	1. Inspect for poor connections at the harness connector of the ECM. 2. Refer to Testing for Poor Connections. Did you find and correct the condition?	—	Go To Step 17	Go To Step 16
11	Repair the open in the IC ground circuit Refer to Wiring Repairs in Wiring Systems. Did you complete the repair?	—	Go To Step 17	—
12	Repair the short to ground in the IC timing control circuit Refer to Wiring Repairs in Wiring Systems. Did you complete the repair?	—	Go To Step 17	—
13	Repair the short to voltage in the IC timing control circuit Refer to Wiring Repairs in Wiring Systems. Did you complete the repair?	—	Go To Step 17	—
14	Repair the open in the ignition voltage circuit Refer to Wiring Repairs in Wiring Systems. Did you complete the repair?	—	Go To Step 17	—
15	Replace the ICM. Refer to ICM replacement. Did you complete the replacement?	—	Go To Step 17	—
16	Replace the ECM. Refer to ECM replacement. Did you complete the replacement?	—	Go To Step 17	—

DTC 41 - Enhanced Ignition System (cont'd)

Step	Action	Value	Yes	No
17	1. Use the scan tool in order to clear the DTCs. 2. Turn OFF the ignition for 30 seconds. 3. Start the engine. 4. Idle the engine at the normal operating temperature	—	<i>Go To</i> Step 18	<i>Go To</i> Step 2
18	Select the Diagnostic Trouble Code (DTC) option. Does the scan tool display any DTCs that you have not diagnosed?	—	<i>Go To</i> the applicable DTC table	System OK

Electronic Ignition System



MEFI4016iatfmHVS
12-17-01

Electronic Ignition System

System Description

This system includes the distributor, the camshaft position (CMP) sensor, the ignition control (IC) module, the secondary wires, the spark plugs, the knock sensors (KS), and the crankshaft position (CKP) sensor. The ignition system is controlled by the engine control module (ECM). The ECM monitors the information from various engine sensors, computes the desired spark timing, and controls the dwell and firing of the ignition coil via IC line to the IC module.

Test Description

Important: The battery should be fully charged prior to any tests.

The numbers below refer to the step numbers on the diagnostic table.

3. This step checks for proper spark output. This check can be used in case of an ignition miss, because the system may provide enough voltage to run the engine but not enough to operate a spark plug under heavy load.
4. This test separates the distributor cap, rotor, and ignition wires from the ignition coil in order to help identify a secondary ignition system problem.
6. This test checks the ignition control module (ICM), connections, and wiring.
12. This test begins to determine if the ECM is providing a signal to the ICM. If the ECM is not providing a signal to the ignition control module, the problem exists between the ignition control module and the ECM.
14. This test checks for a basic engine mechanical problem.

Step	Action	Value	Yes	No
1	Did you perform the On-Board Diagnostic (OBD) system check?	—	Go to Step 2	Go to OBD System Check
2	1. Crank the engine. 2. Observe the Engine Speed parameter with the scan tool. Does the scan tool display engine RPM?	—	Go To Step 3	Go To Step 19
3	1. Check the spark plug wires for open circuits, cracks, or improper seating of terminals at the spark plugs, distributor, and ignition coil before proceeding with the test. 2. Check spark at the plug with approved Spark Tester or equivalent while cranking. If there is no spark on one wire, check a second wire. A few sparks then nothing is considered no spark. Does spark occur on all cylinders?	—	Go To Intermittent Conditions	Go To Step 4
4	1. Remove the coil wire from the distributor cap. 2. Insert the Spark Tester into the coil wire and clamp the tester onto a ground. 3. Crank the engine. Does spark occur?	—	Go To Step 13	Go To Step 5
5	Measure the coil wire resistance. Does the resistance measure approximately the specified value?	1,000 ohm/in.	Go To Step 6	Go To Step 32

Electronic Ignition System (cont'd)

Step	Action	Value	Yes	No
6	1. Disconnect the ignition coil harness connector. 2. Probe the harness ignition coil driver circuit (PIN C) with a test lamp connected to battery positive voltage. 3. Crank the engine. Does the test lamp flash while cranking the engine?	—	Go To Step 8	Go To Step 7
7	1. Turn OFF the ignition. 2. Probe the harness ignition coil driver circuit (PIN C) with a test lamp connected to battery positive voltage. Does the test lamp illuminate?	—	Go To Step 29	Go To Step 9
8	1. Turn ON the ignition, with the engine OFF. 2. Measure the coil ignition voltage (PIN A) with a DMM connected to a ground. Does the voltage measure above the specified value?	10.0	Go To Step 22	Go To Step 18
9	1. Turn OFF the ignition. 2. Check for an open circuit between the ignition coil and the ICM. Did you find the condition?	—	Go To Step 28	Go To Step 10
10	1. Turn ON the ignition, with the engine OFF. 2. Measure the coil ignition voltage (PIN A) at the ICM harness connector with a DMM connected to a ground. Does the voltage measure above the specified value?	10.0	Go To Step 11	Go To Step 20
11	Probe the ICM harness connector ground circuit (PIN C) with a test lamp connected to battery positive voltage. Does the test lamp illuminate?	—	Go To Step 12	Go To Step 24
12	1. Probe the IC timing control circuit (PIN B) with a DMM set to the AC scale connected to a ground. 2. Crank the engine. 3. Observe the voltage while the engine is being cranked. Does the voltage measure within the specified values?	1.0-4.0	Go To Step 21	Go To Step 15

Electronic Ignition System (cont'd)

Step	Action	Value	Yes	No
13	1. Remove the distributor cap. 2. Check the cap for the following conditions: <ul style="list-style-type: none"> • Cracks • Moisture • Carbon tracks • Physical damage Did you find any of these conditions?	—	Go To Step 34	Go To Step 14
14	1. Crank the engine. 2. Observe the distributor rotor while the engine is being cranked. Did the distributor rotor turn?	—	Go To Step 33	Go To Diagnostic Starting Point in EM
15	1. Turn OFF the ignition 2. Disconnect the ECM. 3. Check the ignition timing control circuit for an open between the ECM and the ICM. Did you find the condition?	—	Go To Step 25	Go To Step 16
16	Probe the ignition timing control circuit at the ECM (PIN 31) with a test lamp connected to battery voltage. Does the test lamp illuminate?	—	Go To Step 26	Go To Step 17
17	1. Turn ON the ignition, with the engine OFF. 2. Probe the ignition timing control circuit (PIN 31) at the ECM with a test lamp connected to a ground. Does the test lamp illuminate?	—	Go To Step 27	Go To Step 23
18	Check for an open or shorted to ground ignition voltage circuit at the ignition coil. Repair as necessary. Refer to Wiring Repairs in Wiring Systems. Did you complete the repair?	—	Go To Step 37	—
19	Check for a short to ground on the CKP or CMP depower circuit. Repair as necessary. Refer to Wiring Repairs in Wiring Systems. Did you find and correct the condition?	—	Go To Step 37	Go To Step 23
20	Check for an open or a short to ground on the ignition voltage circuit at the ICM. Repair as necessary. Refer to Wiring Repairs in Wiring Systems. Did you complete the repair?	—	Go To Step 37	—

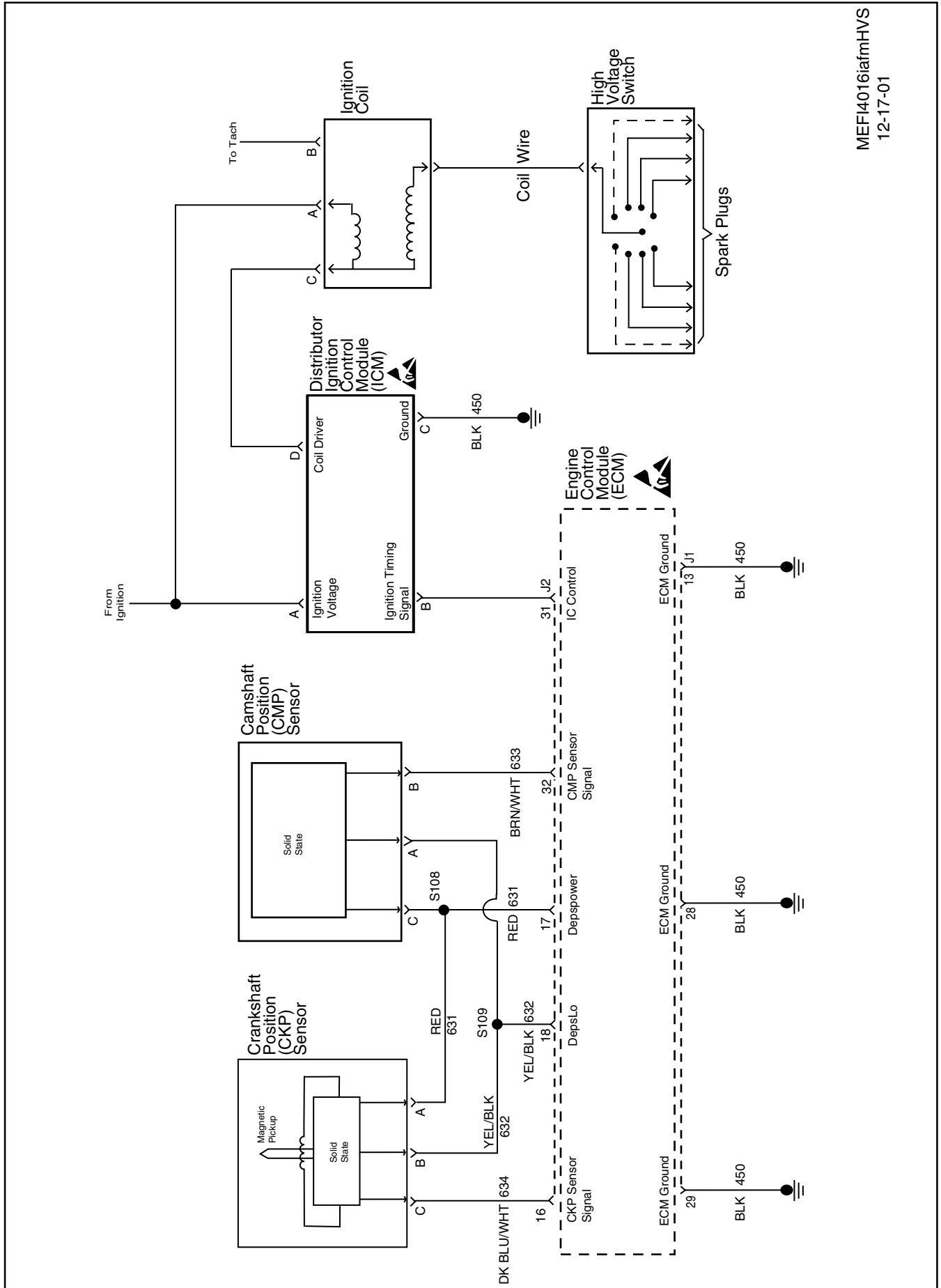
Electronic Ignition System (cont'd)

Step	Action	Value	Yes	No
21	Check for a poor ICM connection. Did you find a problem?	—	Go To Step 30	Go To Step 35
22	Check for a poor coil connection. Did you find a problem?	—	Go To Step 30	Go To Step 31
23	Check for a poor ECM connection. Did you find a problem?	—	Go To Step 30	Go To Step 36
24	Repair the open ICM ground circuit. Refer to Wiring Repairs in Wiring Systems. Did you complete the repair?	—	Go To Step 37	—
25	Repair the open ignition timing control circuit. Refer to Wiring Repairs in Wiring Systems. Did you complete the repair?	—	Go To Step 37	—
26	Repair the grounded ignition timing control circuit. Refer to Wiring Repairs in Wiring Systems. Did you complete the repair?	—	Go To Step 37	—
27	Repair the short to voltage in the ignition timing control circuit. Refer to Wiring Repairs in Wiring Systems. Did you complete the repair?	—	Go To Step 37	—
28	Repair the open in the coil driver circuit between the ignition coil and the ICM. Refer to Wiring Repairs in Wiring Systems. Did you complete the repair?	—	Go To Step 37	—
29	Repair the short to ground in the coil driver circuit between the ignition coil and the ICM. Refer to Wiring Repairs in Wiring Systems. Did you complete the repair?	—	Go To Step 37	—
30	Repair the circuit as necessary. Refer to Wiring Repairs in Wiring Systems. Did you complete the repair?	—	Go To Step 37	—
31	Replace the ignition coil. Refer to Ignition Coil Replacement. Did you complete the replacement?	—	Go To Step 37	—
32	Replace the coil wire. Refer to Spark Plug Replacement. Did you complete the replacement?	—	Go To Step 37	—
33	Replace the distributor rotor. Refer to Distributor Overhaul. Did you complete the replacement?	—	Go To Step 37	—

Electronic Ignition System (cont'd)

Step	Action	Value	Yes	No
34	Replace the distributor cap. Refer to Distributor Overhaul. Did you complete the replacement?	—	Go To Step 37	—
35	Replace the IC module. Refer to Ignition Control Module Replacement. Did you complete the replacement?	—	Go To Step 37	—
36	Replace the ECM. Refer to Engine Control Module Replacement. Did you complete the replacement?	—	Go To Step 37	—
37	Operate the vehicle within the conditions under which the original symptom was noted. Does the system now operate properly?	—	System OK	Go To Step 1

DTC 81 - Crankshaft Position Sensor (CKP)



MEFI4016iafmHVS
12-17-01

DTC 81 - Crankshaft Position Sensor (CKP)

Circuit Description

The crankshaft position (CKP) sensor signal indicates the crankshaft speed and position. The CKP sensor is connected directly to the engine control module (ECM), and consists of the following circuits:

The Depspower circuit

The Depslo circuit

The Reference circuit

Conditions for Running the DTC

The camshaft position (CMP) sensor is transitioning.

Conditions for Setting the DTC

The PCM determines no signal from the CKP sensor for more than 30 seconds.

Diagnostic Aids

The following conditions may cause this DTC to set:

- Poor connection or poor terminal tension at the sensor
- Crankshaft reluctor wheel damage or improper installation

- Excessive air gap between the CKP sensor and the reluctor wheel.
- The engine running out of fuel
- Foreign material passing between the sensor and the reluctor wheel

Excess crankshaft end play causes the CKP sensor reluctor wheel to move out of alignment with the CKP sensor. This could result in any one of the following:

- A no start
- A start and stall
- Erratic performance

An intermittent condition.

Test Description

The numbers below refer to the step numbers on the diagnostic table.

3. This step determines if the fault is present.

DTC 81 - Crankshaft Position Sensor (CKP)

Step	Action	Value	Yes	No
1	Did you perform the Diagnostic System Check-Engine Controls?	—	Go To Step 2	Go To
2	Does the engine start and continue to run?	—	Go To Step 3	Go To Step 4
3	1. Start the engine. 2. Operate the vehicle within the Conditions for Running the DTC. Does the DTC fail this ignition?	—	Go To Step 4	Go To Diagnostic Aids
4	1. Important: An internally shorted CAM sensor can cause DTC 81 to set. Test this circuit for a short before proceeding with this diagnostic table. Turn ON the ignition, with the engine OFF. 2. Disconnect the CKP sensor harness connector. 3. Using the DMM, measure the voltage from the CKP sensor Depspower circuit and a good ground. Does the DMM display the specified value?	B+	Go To Step 5	Go To Step 7
5	Using the DMM, measure the voltage between the CKP sensor Depspower circuit and the CKP sensor Depslo circuit. Does the DMM display the specified value?	B+	Go To Step 6	Go To Step 8

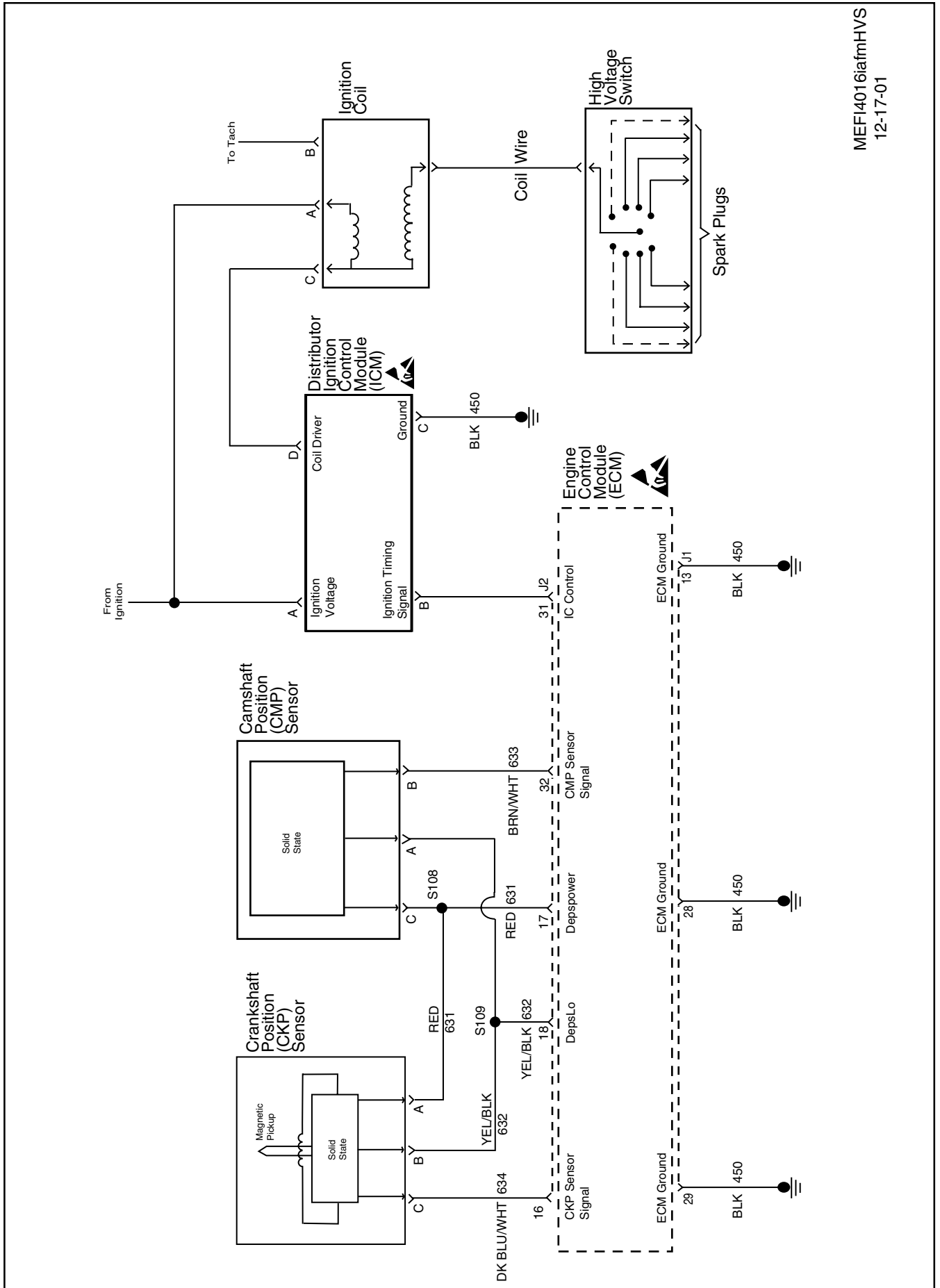
DTC 81 - Crankshaft Position Sensor (CKP)(cont'd)

Step	Action	Value	Yes	No
6	1. Turn OFF the ignition. 2. Connect jumpers between the engine harness connector and the CKP sensor connector of the Depspower circuit and the Depslo circuit. 3. Connect a DMM set to the duty cycle position between the reference circuit of the CKP sensor and a good known ground. Select AC voltage and press the Hz button twice in order to display the duty cycle.	40-60%	Go To Step 9	Go To Step 10
7	1. Test for an open or short to ground in the CKP sensor Depspower circuit. 2. If you find an open or a short to ground, repair the circuit as necessary. Did you find and correct the condition?	—	Go To Step 16	Go To Step 14
8	1. Test for an open or a poor connection in the CKP sensor Depslo circuit. 2. If you find an open or poor connection, repair the condition as necessary. Did you find and correct the condition?	—	Go To Step 16	Go To Step 14
9	1. Test the CKP sensor reference circuit for the following conditions: <ul style="list-style-type: none"> • An open • A short to ground or Depslo • A short to voltage or Depspower 2. Repair the circuit as necessary. Did you find and correct the condition?	—	Go To Step 16	Go To Step 11
10	1. Inspect for poor connections at the CKP sensor. 2. If you find a poor connection repair the condition as necessary. Did you find and correct the condition?	—	Go To Step 16	Go To Step 11
11	1. Remove the CKP sensor. 2. Visually inspect the CKP sensor for the following conditions: <ul style="list-style-type: none"> • Physical damage • Loose or improper installation • Wiring routed too closely to secondary ignition components 3. Repair the circuit as necessary. Did you find and correct the problem?	—	Go To Step 16	Go To Step 12

DTC 81 - Crankshaft Position Sensor (CKP)(cont'd)

Step	Action	Value	Yes	No
12	1. Inspect the CKP reluctor wheel for damage or looseness. 2. Refer to Diagnostic Aids in DTC 81. Did you find and correct the condition?	—	<i>Go To Step 16</i>	<i>Go To Step 13</i>
13	1. Replace the CKP sensor. Did you complete the repair?	—	<i>Go To Step 16</i>	—
14	1. Inspect for poor connections at the ECM. 2. If you find a poor connection, repair the condition as necessary. Did you complete the repair?	—	<i>Go To Step 16</i>	<i>Go To Step 15</i>
15	Replace the ECM. Did you complete the replacement?	—	<i>Go To Step 16</i>	—
16	1. Use the scan tool in order to clear the DTCs. 2. Turn OFF the ignition for 30 seconds. 3. Start the engine. 4. Operate the vehicle within the Conditions for Running the DTC as specified in the supporting text. Does the DTC run and pass?	—	<i>Go To Step 17</i>	<i>Go To Step 2</i>
17	With a scan tool, observe the stored information, Capture info. Does the scan tool display any DTC that you have not diagnosed?		<i>Go To</i>	System OK

DTC 81 - Camshaft Position Sensor (CMP)



MEFI4016iatfmHVS
12-17-01

DTC 81 - Camshaft Position Sensor (CMP)**Circuit Description**

The camshaft position (CMP) sensor is a sensor designed to detect changes in a magnetic field. The control module supplies the CMP sensor with the following:

A Depspower

A Depslo circuit

A signal circuit

The CMP sensor produces a magnetic field whenever the ignition is ON. The CMP sensor is mounted near a reluctor wheel that is attached to the distributor shaft. When the distributor shaft rotates, or when the engine is cranking or

running, the reluctor wheel changes the magnetic field. The CMP sensor converts each change in the magnetic field into a PULSE. The number of teeth on the reluctor wheel determines how many pulses the CMP sensor detects per camshaft rotation. If the engine control module (ECM) does not detect the CMP signal while the engine is running, this diagnostic trouble code (DTC) will set.

DTC 81 - Camshaft Position Sensor (CMP)

Step	Action	Value	Yes	No
1	Did you perform the "On Board Diagnostic" (OBD) System Check?	—	Go To Step 2	Go To OBD system check
2	1. Turn OFF the ignition. 2. Disconnect the CMP sensor connector. 3. Turn ON the ignition, with the engine OFF. 4. Probe the Depspower circuit of the CMP sensor harness connector with a test lamp connected to ground. Does the test lamp illuminate?	—	Go to Step 4	Go to Step 3
3	Probe the Depspower circuit of the CMP sensor harness connector with a test lamp connected to battery voltage. Does the test lamp illuminate?	—	Go To Step 10	Go To Step 9
4	Probe the Depslo circuit of the CMP sensor harness connector with a test lamp connected to battery voltage. Does the test lamp illuminate?	—	Go To Step 5	Go To Step 11
5	1. Jumper the Depspower circuit from the CMP sensor to the CMP sensor harness connector using J 35616-A connector test adapter kit. 2. Jumper the Depslo circuit from the CMP sensor to the CMP sensor harness connector. 3. Set the DMM to the DC voltage scale and press the hertz button twice in order to locate the % scale.			

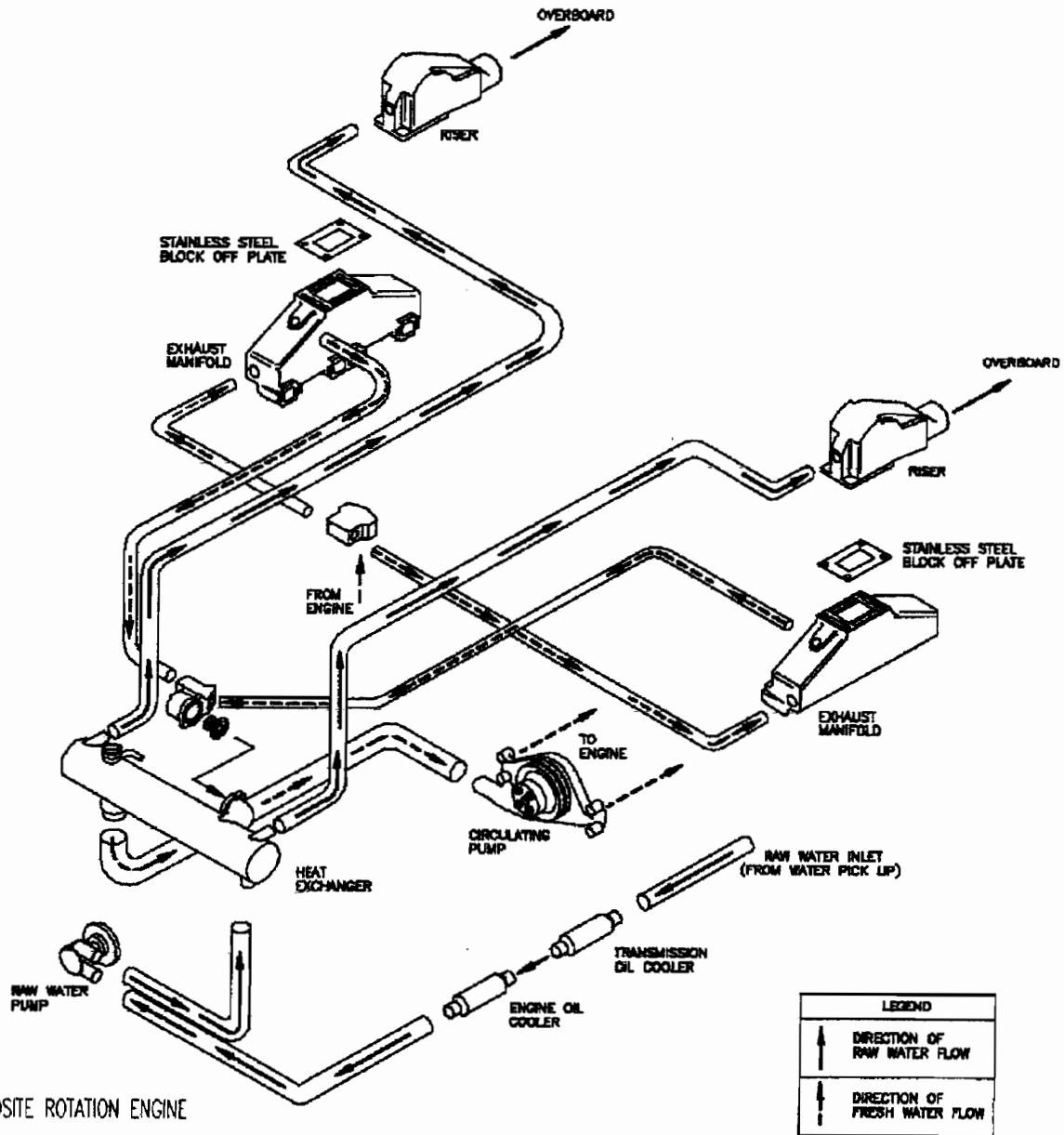
DTC 81 - Camshaft Position Sensor (CMP) (cont'd)

Step	Action	Value	Yes	No
5 (cont'd)	4. Measure the Duty Cycle from the CMP sensor signal circuit of the CMP sensor to a good ground with a DMM. 5. Start the engine. Is the Duty Cycle within the specified value?	45-55%	Go To Step 6	Go To Step 15
6	1. Disconnect the ECM. 2. Measure the resistance of the CMP sensor signal circuit from the CMP sensor harness connector to the ECM harness connector with a DMM. Refer to Circuit testing in wiring systems. Is the resistance above the specified value?	5 ohms	Go To Step 12	Go To Step 7
7	1. Connect the ECM connector. 2. Probe the signal circuit of the CMP sensor harness connector with a test lamp connected to battery voltage. Refer to Probing Electrical Connectors in Wiring Systems. Does the test lamp illuminate?	—	Go To Step 13	Go To Step 8
8	Probe the signal circuit of the CMP sensor harness connector with a test lamp connected to a good ground. Refer to Probing Electrical Connectors in Wiring Systems. Does the test lamp illuminate?	—	Go To Step 14	Go To Step 16
9	Test the Depspower circuit for an open or high resistance. Refer to Circuit Testing and Wiring Repairs in Wiring Systems. Did you find and correct the condition?	—	Go To Step 19	Go To Step 16
10	Test the Depspower circuit for a short ground. Refer to Circuit Testing and Wiring Repairs in Wiring Systems. Did you find and correct the condition?	—	Go To Step 19	Go To Step 16
11	Test the Depslo circuit for an open or high resistance. Refer to Circuit Testing and Wiring Repairs in Wiring Systems. Did you find and correct the condition?	—	Go To Step 19	Go To Step 16
12	Test the signal circuit for an open or high resistance. Refer to Circuit Testing and Wiring Repairs in Wiring Systems. Did you find and correct the condition?	—	Go To Step 19	Go To Step 16

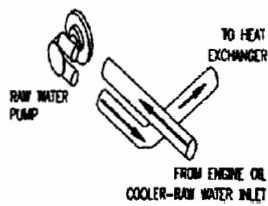
DTC 81 - Camshaft Position Sensor (CMP) (cont'd)

Step	Action	Value	Yes	No
13	Test the signal circuit for a short to ground. Refer to Circuit Testing and Wiring Repairs in Wiring Systems. Did you find and correct the condition?	—	Go To Step 19	Go To Step 16
14	Test the signal circuit for a short to voltage. Refer to Circuit Testing and Wiring Repairs in Wiring Systems. Did you find and correct the condition?	—	Go To Step 19	Go To Step 16
15	Test for an intermittent and for a poor connection at the CMP harness connector. If you find a poor connection, repair the connectors as necessary. Did you find and correct the condition?	—	Go To Step 19	Go To Step 17
16	Test for an intermittent and for a poor connection at the ECM harness connector. If you find a poor connection, repair the connectors as necessary. Did you find and correct the condition?	—	Go To Step 19	Go To Step 18
17	Replace the CMP sensor. Refer to CMP sensor Replacement. Did you complete the replacement?	—	Go To Step 19	—
18	Replace the ECM. Refer to ECM sensor Replacement. Did you complete the replacement?	—	Go To Step 19	—
19	1. Use the scan tool in order to clear the DTCs. 2. Turn OFF the ignition for 30 seconds. 3. Start the engine. 4. Operate the vehicle within the Conditions for Running the DTC. Does the DTC run and pass?	—	Go To Step 20	Go To Step 2
20	Select the Diagnostic Trouble Code (DTC) option. Does the scan tool display any DTCs that you have not diagnosed?		Go To DTC List	System OK

Coolant Flow Diagram Closed Cooling (Front Mount)

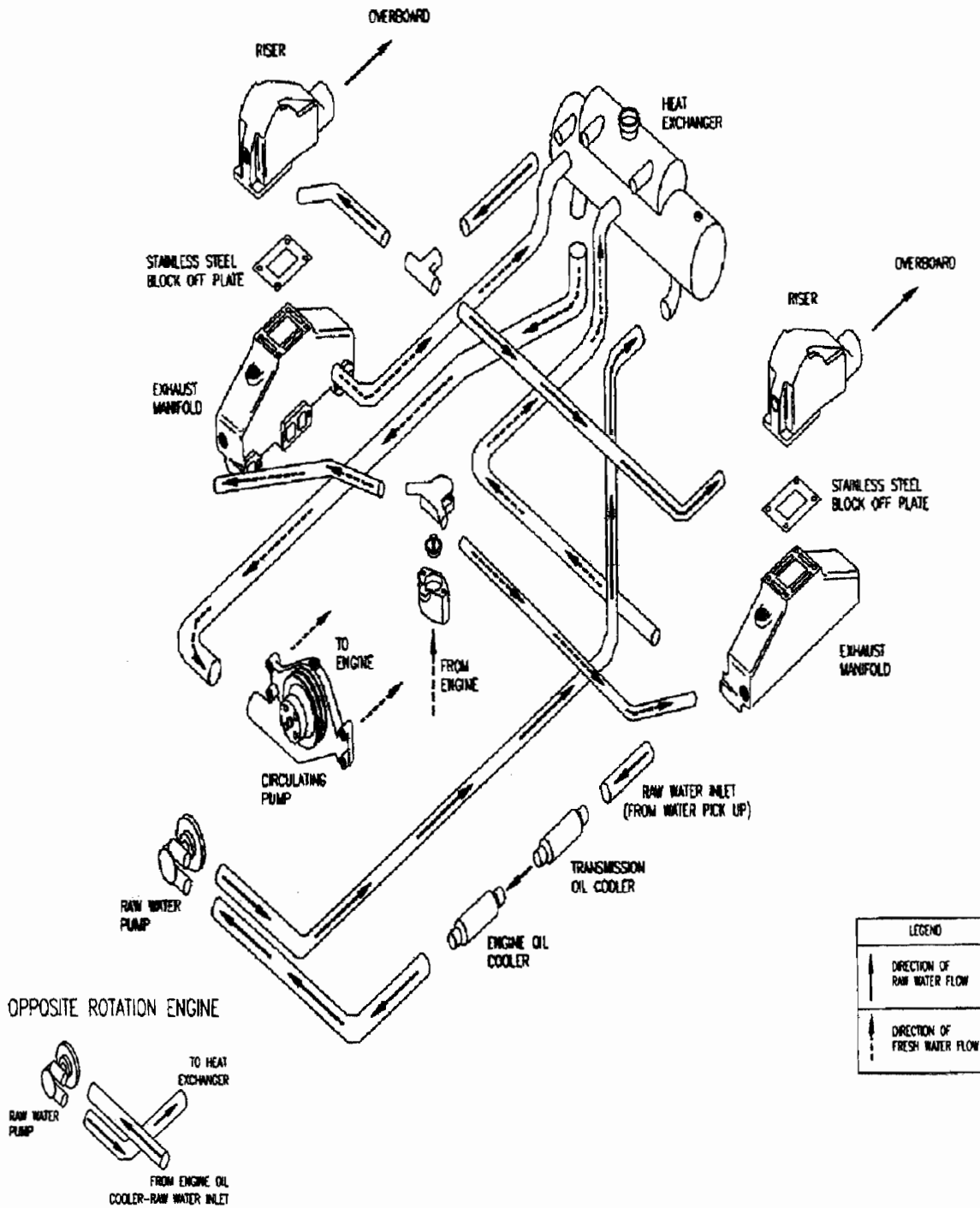


OPPOSITE ROTATION ENGINE



Coolant Flow Diagram

Closed Cooling (Rear Mount)



DRAINING COOLING SYSTEM **Raw Water Cooling**

WARNING! Before draining cooling system, allow engine to cool. Exercise caution when draining system as water may remain hot for an extended period of time in the internal water jackets of the engine.

NOTE: Place an appropriate container under the drain points to collect coolant. This minimizes accumulation of water in the bilge. Dispose of excess coolant mixture properly.

Remove or Disconnect:

1. Water drain plug from engine/transmission oil cooler.
2. Four bolts from raw water pump front cover and remove cover.
3. Exhaust manifold drain plugs from the aft end of each manifold and from engine block. On the 181/250 C ID manifold, drain plugs are on the bottom.
4. Hose from water circulating pump.
5. Thermostat from housing. **NOTE:** Allow water to drain completely from entire system before re-assembly.

Clean or Inspect:

1. Hoses and clamps for signs of cracking, swelling or fatigue. Replace if necessary.
2. Thermostat for deterioration, damaged spring, or scale build-up. Replace if necessary.
3. All drain holes for thread damage or erosion. Chase the threads with the proper pipe thread tap, if necessary.

Install or Connect:

1. Thermostat to housing.
2. Hose to water circulating pump.
3. Exhaust manifold drain plugs into aft end of each manifold and port and starboard side of engine

block. **NOTE:** Coat the threads of the plugs with non-hardening sealer or apply Teflon® tape to insure proper seal.

4. Front cover to raw water pump using the four bolts.
NOTE: install a new gasket on the front cover, **DO NOT** use the old gasket as it will not seal properly.
5. Water drain plug into the engine/transmission oil cooler.

DRAINING COOLING SYSTEM **Closed Cooling System**

WARNING! Before draining cooling system, allow engine to cool. Exercise caution when draining system as water may remain hot for an extended period of time in the internal water jackets of the engine.

NOTE: Place an appropriate container under the drain points to collect coolant. This minimizes accumulation of water in the bilge. Dispose of excess coolant mixture properly.

Remove or Disconnect:

1. Water drain plug from engine/transmission oil cooler.
2. Four bolts from raw water pump front cover and remove cover.
3. Drain plug from raw water side of heat exchanger.

NOTE: The following steps will drain the fresh water coolant from the system. Keep this coolant separate so that it may be reused if antifreeze/water mixture is reusable. Consult local authorities on the proper methods of disposal of used antifreeze. Careless disposal is an environmental hazard and can bring stiff penalties if discovered.

4. Drain plugs from exhaust manifold(s) on the aft end. On 181/250 C ID manifolds, drain plugs are located on the bottom of the manifold.

DRAIN COOLING SYSTEM**Closed Cooling System (Continued)**

5. Drain plugs from the port and starboard side of the engine block.
6. Pressure cap from heat exchanger.
7. Fresh water drain plug from heat exchanger.
8. Zinc anode from heat exchanger.
9. Thermostat from housing on heat exchanger.

Clean or Inspect:

1. Hoses and clamps for signs of cracking, swelling, or fatigue. Replace if necessary.
2. Thermostat for deterioration, damaged spring, or scale build-up. Replace if necessary.
3. All drain holes for thread damage or erosion. Chase the threads with the proper pipe thread tap if necessary.
4. Zinc anode for erosion, replace if necessary. See "Zinc Anode Replacement" section below.

Install or Connect:

1. Thermostat in housing.
2. Zinc anode in heat exchanger. See "Zinc Anode Replacement" section below.
3. Fresh water drain plug in heat exchanger.
4. Drain plugs in port and starboard side of block.
NOTE: Apply a non-hardening thread sealing Compound or Teflon® tape to plug threads for proper sealing.
5. Drain plugs in the exhaust manifolds.
6. Drain plug in raw water side of heat exchanger.
7. Raw water pump front cover and new gasket with four bolts.
8. Drain plug in engine/transmission oil cooler.
9. Pressure cap onto heat exchanger.

ZINC ANODE REPLACEMENT
(Fresh Water Cooled Only)

NOTE: It is recommended that the zinc anode be inspected every 50 hours of engine operation or two weeks, whichever comes first.

Remove or Disconnect:

1. Zinc anode from the top of the heat exchanger.

Clean or Inspect:

1. Zinc anode for erosion. If little or no erosion is visible, tap the anode *lightly* with a hammer. If the anode disintegrates or flakes apart, it is no longer useful.
2. Unscrew or drill out zinc anode from plug.

Install or Connect:

1. Fresh zinc anode into plug. *NOTE: It is important that no thread sealant be used on the zinc anode or the plug. There must be only metal-to-metal contact between the anode and the plug and the plug to the cooling system for proper protection.*
2. Plug with anode into top of heat exchanger.

FILLING FRESH WATER
COOLING SYSTEM

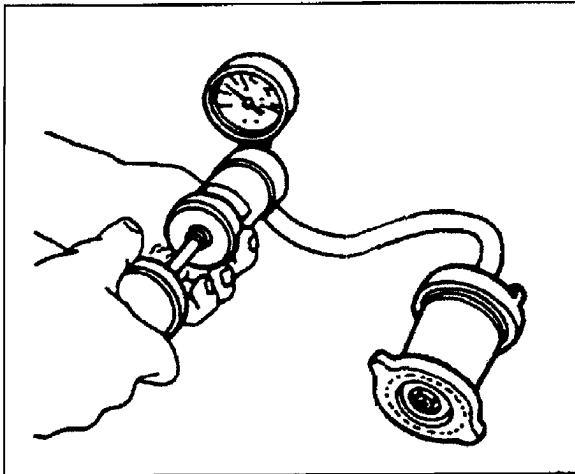
NOTE: Insure all hoses, clamps, plugs and fittings are installed properly and secure before system with antifreeze/water mixture

1. Fill the cooling system through the heat exchanger filler neck to within one (1) inch of the bottom of filler neck.
2. With the pressure cap removed, run engine at fast idle (1500 RPM). Add coolant to maintain the proper level.
3. When engine has reached operating temperature, fill heat exchanger to bottom of filler neck, install pressure cap and check all hoses, gaskets and fittings for leaks.
4. After operating the boat after refilling system, check coolant level and add if necessary.
5. If equipped with recovery bottle, fill bottle to recommended level.

HEAT EXCHANGER PRESSURE CAP TEST

1. Remove cap from heat exchanger after engine has cooled to ambient temperature.
2. Clean any scale or debris from cap and sealing surfaces.
3. Insure locking tabs on cap are not bent or damaged.
4. Test the pressure cap using pressure cap testing tool J-24460-01. Follow directions which accompany the tester. The cap must relieve pressure at 7 psi and hold its rated pressure for thirty (30) seconds without falling below 5 psi.
5. Replace the cap with a new one if it fails the test.
6. Reinstall the cap on the heat exchanger.

HEAT EXCHANGER PRESSURE CHECK



1. Remove pressure cap and install a coolant pressure tester tool J-33419-A.
2. From the heat exchanger, remove a raw water hose going to one of the risers; do not drain the heat exchanger.
3. Pressurize the system to 14 psi.
4. If water begins to flow from the raw water nipple, an internal leak exists and the heat exchanger must be replaced.

PRESSURE CHECKING FRESH WATER COOLING SYSTEM

NOTE: Pits procedure is recommended if the system is suspected of leaking or failing to hold pressure.

1. Remove pressure cap.
2. Clean filler neck of all scale or debris and insure that the sealing surfaces are smooth.
3. Fill coolant to within one (1) inch of the bottom of filler neck.
4. Attach cooling system pressure tester tool J-33419-A and pressurize system to 14 psi.
5. If the gauge indicates a drop in pressure within two (2) minutes, it can be safely assumed that a leak exists in the system.
6. Visually check all hoses, fittings, drain plugs, pump seals, gaskets for leaks or seepage while maintaining 14 psi on the system. Listen for any bubbling or hissing sounds which may indicate a leak. NOTE: if pressure drops and no leaks are found, an internal leaks) should be suspected. Proceed further for diagnosis of internal leaks.
7. Start the engine and repressurize the system to 14 psi.
8. Observe the pressure gauge for any fluctuations or vibration of the needle. If the needle fluctuates then pressure from the combustion chamber is escaping into the fresh water cooling jackets.
9. To determine which cylinder is leaking, remove spark plug wires one at a time while observing the gauge. When the gauge needle stops fluctuating, the problem cylinder has been located.
10. Remove the spark plug of the suspected cylinder and inspect it to confirm the leak. If the spark plug appears very clean or has a milky film, the leak is in that cylinder.
11. If no leaks appear in the cylinders, drain the oil and check for coolant contamination. The oil will have a milky appearance if coolant is present.
12. Remove oil pan and repressurize the cooling system to 14 psi and inspect the internal surfaces of the engine for leaks or coolant seepage.

PRESSURE CHECKING FRESH WATER
COOLING SYSTEM (Continued)

**FLUSHING RAW WATER
COOLING SYSTEM**

NOTE: Flushing the raw water system is recommended after operation in salt water or water that is heavily polluted or silty.

1. Disconnect raw water inlet hose from the raw water pump. NOTE: if boat is in the water, shut off the water inlet valve to prevent flooding the boat.
2. Connect a fresh tap water hose to the pump inlet and turn tap water on approximately half way.
3. Start engine and idle for approximately ten (10) minutes or until the discharged water is clean.

CAUTION! Do not operate the engine above idle as it may require more water than the tap water hose can supply causing the engine to overheat.

4. Stop engine and shut off the tap water supply.
5. Remove the connector from the pump inlet and reconnect the water inlet hose.
6. Insure water inlet valve is open before boat operation.

TROUBLESHOOTING ENGINE OVERHEATING :

When troubleshooting the coolant system, it is advisable to check the obvious first, such as broken belts, hoses, housings, manifolds, etc. If this does not resolve the problem, begin inspecting the system by following the water flow from the sea water pick-up to where the water is dumped overboard with the exhaust. The following steps will guide you through the coolant troubleshooting process.

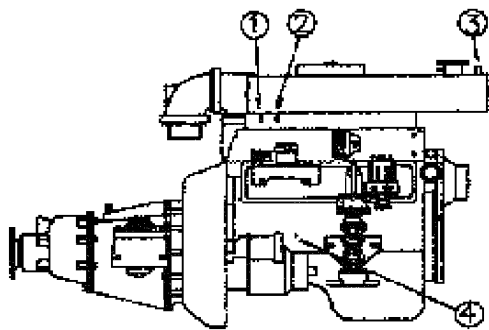
-
- Loose or broken circulating pump belt
 - Inaccurate temperature gauge or temperature sending unit
 - Algae or barnacle build-up forward of water inlet, causing turbulence
 - Air entering system
 - Water circulating pump malfunctioning
 - Thermostat malfunctioning
 - Blockage in transmission/engine oil cooler
 - Impeller in raw water pump defective
 - Blockage in heat exchanger (sea water circuit)
 - Build up of scale and/or deposits in exhaust manifold or riser
 - Low coolant level in closed cooling system
 - Excessively high concentration of anti-freeze
 - Exhaust riser dump fittings contacting inner jacket of riser
 - Incorrect ignition timing
 - Detonation
 - Engine lugging/operating below proper rpms @ WOT
 - Fuel/air mixture too lean
 - Exhaust flappers stuck closed
 - Hot water heater improperly plumbed
 - Replace belt and tighten to specifications
 - Remove temperature sending unit on engine and attach a mechanical gauge. If operating temperature is normal, replace sending unit.
 - Remove build up
 - Pressure check radiator/tank cap. If defective, replace with dual seal type cap.
 - Replace circulating pump
 - Replace thermostat
 - Remove hose from water inlet side of cooler and check for and remove obstruction.
 - Replace impeller
 - Remove end plate on raw water side of heat exchanger, check for and remove obstruction from core tubing.
 - Remove manifold or riser and have them cleaned and serviced
 - Refill heat exchanger with proper mixture of coolant and add coolant to the overflow reservoir, fill to proper mark.
 - Drain coolant and refill with proper concentration (50/50) of antifreeze and water. NOTE: Warm or hot climates may require a mixture of only pure soft water with a rust inhibitor.
 - Remove fitting and replace with one have a shorter thread bearing surface
 - Tune engine according to "Tune-up Specifications" in this manual
 - Use spark plugs within proper head range or insure boat is operating within parameters
 - Check fuel/air mixture at carburetor, timing, propeller application, etc.
 - Adjust carburetor to proper specifications
 - Free flappers or replace if necessary
 - Plumb water heater according to manufacturers specifications

WATER IN CYLINDERS

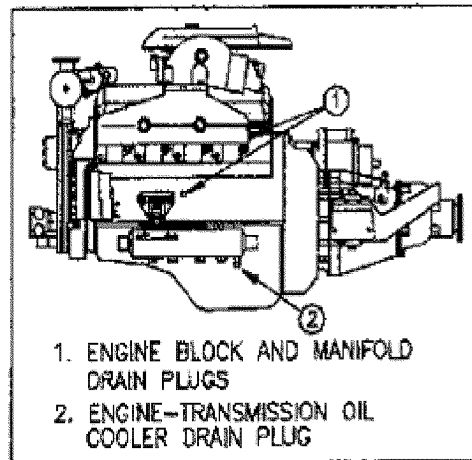
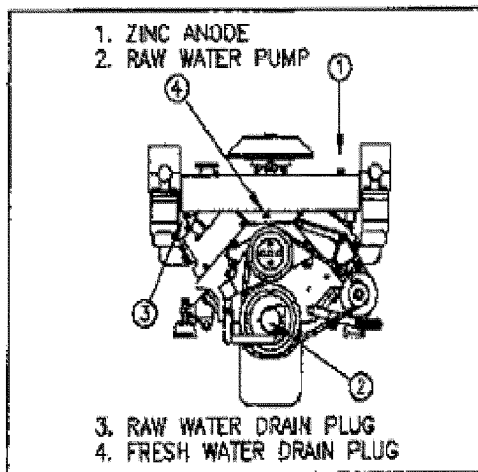
Cause	Correction
<ul style="list-style-type: none"> • Water washes back up through exhaust system and enters the cylinders 	<ul style="list-style-type: none"> • Ensure exhaust system is installed with proper slope and avoid abrupt power reductions which cause the wake to wash high upon the transom
<ul style="list-style-type: none"> • Blown cylinder head gasket 	<ul style="list-style-type: none"> • Replace gasket and have cylinder block and head checked for warpage
<ul style="list-style-type: none"> • Cylinder head boils loose 	<ul style="list-style-type: none"> • Re-torque head bolts and run engine, check for water in cylinder(s)
<ul style="list-style-type: none"> • Cracked exhaust manifold 	<ul style="list-style-type: none"> • Remove manifold and have it repaired if possible

IMPORTANT! DO NOT use aftermarket cooling system sealers to seal leaks in marine cooling systems. This will lead to blockage and overheating in the engine or manifolds.

FRESH WATER COOLING SYSTEM DRAIN POINT DIAGRAMS



1. RAW WATER DRAIN PLUG
2. FRESH WATER DRAIN PLUG
3. ZINC ANODE
4. ENGINE BLOCK DRAIN PLUG



Diagnostic Information and Procedures

Base Engine Misfire Diagnosis

Checks	Action
<p>Engine Performance diagnosis procedures are covered in Engine Controls and should be consulted for diagnosis of any Drivability, Emissions or Malfunctioning Indicator Lamp (MIL) concerns.</p> <p>The following diagnosis covers common concerns and possible causes.</p> <p>When the proper diagnosis is made, the concern should be corrected by adjustment, repair or replacement as required.</p> <p>Refer to the appropriate section of the service manual for each specific procedure.</p> <p>This diagnostic table will assist in engine misfire diagnosis due to a mechanical concern such as a faulty engine camshaft, worn or damaged bearings or bent valve pushrod.</p> <p>This table will not isolate a crossed fuel injector wire, faulty fuel injector or any other drivability component failure that may cause a misfire.</p> <p>The Powertrain On-Board Diagnostic System checks must be performed first.</p> <p>When using this table to make a Base Engine Misfire diagnosis, begin with the preliminary information below and then proceed to the specific category.</p>	
Preliminary	<ol style="list-style-type: none"> 1. Perform DTC P0300 before proceeding with Base Engine Misfire Diagnosis information. DTC P0300 will assist in determining which cylinder or cylinders are misfiring. 2. Perform a visual inspection of the following: <ul style="list-style-type: none"> • A loose or improperly installed engine flywheel or crankshaft balancer • Worn, damaged or misaligned accessory drive system components 3. Listen to the engine for any abnormal internal engine noises. 4. Inspect the engine for acceptable oil pressure. 5. Verify if the engine has excessive oil consumption. 6. Verify if the engine has excessive coolant consumption. 7. Perform a compression test on the engine.
Intake Manifold Leaks	<p>An intake manifold that has a vacuum leak may cause a misfire.</p> <p>Inspect for the following:</p> <ul style="list-style-type: none"> • Improperly installed or damaged vacuum hoses • Faulty or improperly installed lower intake manifold and/or gaskets • Cracked or damaged lower intake manifold • Improperly installed MAP sensor The sealing grommet of the MAP sensor should not be torn or damaged • Improperly installed throttle body or damaged gasket • Warped intake manifold • Warped or damaged cylinder head sealing surface
Coolant Consumption	<p>Coolant consumption may or may not cause the engine to overheat.</p> <p>Inspect for the following:</p> <ul style="list-style-type: none"> • External coolant leaks • Faulty cylinder head gasket • Warped cylinder head • Cracked cylinder head • Damaged engine block
Oil Consumption	<p>Oil consumption may or may not cause the engine to misfire.</p> <ol style="list-style-type: none"> 1. Remove the spark plugs and inspect for an oil fouled spark plug. 2. Perform a cylinder compression test. 3. If the compression test indicates worn valves or valve guides, inspect the following: <ul style="list-style-type: none"> • Worn, brittle or improperly installed valve stem oil seals • Worn valve guides • Worn valve stems • Worn or burnt valves or valve seats 4. If the compression test indicates worn or damaged piston rings, inspect the following: <ul style="list-style-type: none"> • Broken or improperly seated piston rings • Excessive piston ring end gap • Excessive cylinder bore wear or taper • Cylinder damage • Piston damage

Base Engine Misfire Diagnosis (cont'd)

Checks	Action
Abnormal Internal Engine Noises	<ol style="list-style-type: none"> 1. Start the engine and determine if the noise is timed to the engine camshaft speed or the crankshaft speed. 2. Using a timing light, two knocks per flash is the crankshaft speed and one knock per flash is the engine camshaft speed. 3. If the noise is timed to the engine camshaft speed, inspect the following: <ul style="list-style-type: none"> • Missing or loose valve train components • Worn or loose valve rocker arms • Worn or bent valve pushrods • Faulty valve springs • Bent or burnt valves • Worn engine camshaft lobes • Worn or damaged camshaft timing chain and/or sprockets <p>Important: A slight COLD knock or piston slapping noise could be considered normal if not present after the engine has reached normal operating temperatures. If the knock is timed to the crankshaft speed, inspect the following:</p> <ul style="list-style-type: none"> • Worn crankshaft or connecting rod bearings • Piston ro cylinder damage • Worn piston or piston pin • Faulty connecting rod • Excessive carbon build-up on the top of the piston
No Abnormal Internal Engine Noise	<ol style="list-style-type: none"> 1. Inspect for a worn or improperly installed camshaft timing chain and/or sprockets. 2. Remove the valve rocker arm cover on the side of the engine with the cylinder that is misfiring. 3. Inspect for the following: <ul style="list-style-type: none"> • Loose valve rocker arm studs • Bent valve push rods • Faulty valve springs • Faulty valve lifters (bleeding down) • Worn or improperly seated valves • Worn engine camshaft lobes

Engine Compression Test

- | | |
|---|---|
| <ol style="list-style-type: none"> 1. Disconnect the positive ignition coil wire plug from ignition coil. 2. Disconnect the fuel injector electrical connector. 3. Remove all the spark plugs. 4. Block the throttle plate wide open. 5. Charge the battery if the battery is not fully charged. 6. Start with the compression gauge at zero. Then crank the engine through four compression strokes (four puffs). 7. Make the compression check the same for each cylinder. Record the reading.
The minimum compression in any one cylinder should not be less than 70 percent of the highest cylinder. No cylinder should read less than 690 kPa (100 psi). For example, if the highest pressure in any one cylinder is 1035 kPa (150 psi), the lowest allowable pressure for any other cylinder would be 725 kPa (105 psi). (1035 x 70% = 725) (150 x 70% = 105). 8. If some cylinders have low compression, inject approximately 15 ml (one tablespoon) of engine | <p>oil into the combustion chamber through the spark plug hole.</p> <ul style="list-style-type: none"> • Normal - Compression builds up quickly and evenly to the specified compression for each cylinder. • Piston Rings Leaking - Compression is low on the first stroke. Then compression builds up with the following strokes but does not reach normal. Compression improves considerably when you add oil. • Valves Leaking - Compression is low on the first stroke. Compression usually does not build up on the following strokes. Compression does not improve much when you add oil. • If two adjacent cylinders have lower than normal compression, and injecting oil into the cylinders does not increase the compression, the cause may be a head gasket leaking between the two cylinders. <ol style="list-style-type: none"> 9. Install the removed parts. 10. Connect the disconnected components. |
|---|---|

Engine Noise Diagnosis

Symptoms	Cause
<p>When diagnosing engine noise complaints, use the following steps to isolate the source of the engine noise:</p> <ul style="list-style-type: none"> • Determine the type of noise For example, is the noise a light rattle/tapping or a low rumble/knocking? • The exact operating condition under which the noise exists Note factors such as ambient temperature, the amount of engine warm-up time, the engine temperature, the engine RPM and other specifics. • At what rate the noise occurs, and at what location on the engine Engine noises are generally synchronized to either engine speed (crankshaft, engine flywheel, connecting rods, crankshaft balancer or pistons and related components) or one-half engine speed (valve train noise such as valve rocker arms, valve lifters and camshaft timing chain). Determine the rate at which the noise is occurring. • Compare the engine sounds to other engines, and make sure you are not trying to correct a normal condition. 	
Noise on Start-Up but Only Lasts a Few seconds	<ul style="list-style-type: none"> • Improper oil viscosity. Install the recommended oil viscosity for the expected temperatures. • Worn or dirty valve lifters • Excessive piston-to-cylinder bore clearance • Excessive piston pin-to-bore clearance • Excessive crankshaft bearing clearance
Knocks Cold and Continues for 1 to 2 Minutes	<ul style="list-style-type: none"> • Loose or broken crankshaft balancer or accessory drive components • Excessive piston-to-bore clearance A cold piston knock which appears in 1.5 minutes should be considered acceptable. • A cold engine knock usually disappears when the specific cylinders secondary ignition circuit is grounded out.
Intermittent Noise on Idle, Disappearing When Engine Speed is Increased	<ul style="list-style-type: none"> • Improper oil viscosity. Install the recommended oil viscosity for the expected temperatures. • Lower than specified oil pressure Install an oil pressure gauge and measure the engine oil pressure. • Dirty or worn valve lifter
Valve Train Noise (Rattle/Tapping)	<p>The following conditions may cause valve train noise:</p> <ul style="list-style-type: none"> • Lower than specified oil pressure • Worn or faulty oil pump • Loose oil pump-to-engine block bolt • Loose valve rocker arm attachments • Worn valve rocker arms and/or valve pushrods • Broken valve spring • Sticking valves • Worn, dirty or faulty valve lifters • Worn engine camshaft lobes • Worn valve guides or valve stems • Bent, broken or damaged timing chain sprocket teeth
Knocks Hot at Idle (Rumble/Knocking)	<p>The following conditions may cause a knocking noise:</p> <ul style="list-style-type: none"> • Malfunctioning accessory drive system components • Loose or broken crankshaft balancer • Detonation or spark knock Check for proper operation of the cooling, knock and ignition control components. • Refer to diagnostic information in Engine Controls • Excessive connecting rod bearing clearance • Excessive piston pin-to-bore clearance • Bent connecting rod • Excessive crankshaft bearing clearance • Loose torque converter bolts (if equipped) • Cracked or damaged engine flywheel • Exhaust leak at the exhaust manifold • Combustion chamber deposits
Exhaust System Noise and/or Leakage	<p>Exhaust system noise and/or leakage may be caused by the following conditions:</p> <ul style="list-style-type: none"> • Improperly installed or misaligned exhaust system components • A cracked or broken exhaust manifold • Damaged or worn exhaust manifold gaskets and/or seals • Burnt or rusted out exhaust system components • Broken or loose exhaust clamps and/or brackets

Valve Train Diagnosis

General Information

Symptoms	Cause
<ul style="list-style-type: none"> A light tapping noise at 1/2 engine speed, or any varying frequency, may indicate a valve train problem. Tapping noises will typically increase with increased engine speed. Before attempting to diagnose a valve train noise, check for the proper engine oil level and then allow the engine to obtain normal operating temperature. Following this procedure will bring all engine components to a normal state of expansion. Sit in the driver's seat, then operate the engine at various speeds and listen for any abnormal engine noise. 	
Valve Train Noise	<ul style="list-style-type: none"> Low engine oil pressure A worn or faulty oil pump A loose or plugged oil pump screen Loose valve rocker arm attachments (causing excessive valve lash) A worn or damaged valve rocker arm ball A worn valve rocker arm and/or valve pushrod A broken valve spring Sticking valves Valve lifters worn, dirty or faulty A broken valve lifter guide Engine camshaft lobes worn Worn valve guides or valve stems Bent valve pushrods Excessive free play in the camshaft timing chain Bent, broken or damaged camshaft sprocket teeth

Diagnostic Table

Step	Action	Value(s)	Yes	No
DEFINITION: A light tapping noise at 1/2 engine speed, or any varying frequency.				
1	Is there valve train noise?	—	Go to Step 2	System OK
2	Check for a high engine oil level. An engine with the engine oil level above the FULL mark on the oil level indicator allows the crankshaft counterweights to churn the engine oil into foam. When the foamy engine oil is pumped into the valve lifters, the valve lifters become noisy. A solid column of engine oil ensures proper valve lifter operation. Is the engine oil level too high?	—	Go to Step 3	Go to Step 4
3	Drain the engine oil to the proper level. Is the tapping noise gone?	—	System OK	Go to Step 6
4	Check for a low engine oil level. An engine with the engine oil level below the ADD mark on the oil level indicator may allow the oil pump to pump air at high engine RPM. Is the engine oil level below the ADD mark on the oil level indicator?	—	Go to Step 5	Go to Step 6
5	Add the engine oil as required. Is the tapping noise gone?	—	System OK	Go to Step 6
6	Check for the proper engine oil pressure. Refer to <i>Engine Mechanical Specifications and Oil Pressure Diagnosis and Testing</i> . Is the engine oil pressure within specifications?	41.4 kPa (6 psi)	Go to Step 11	Go to Step 7

Diagnostic Table (cont'd)

Step	Action	Value(s)	Yes	No
7	Check the oil pump screen for damage or a loose fit to the oil pump. Is the oil pump screen loose or is the oil pump screen damaged?	—	Go to Step 8	Go to Step 9
8	Repair as required. Is the tapping noise gone?	—	System OK	Go to Step 9
9	Check for a damaged oil pump or loose bolts. Refer to <i>Oil Pump Clean and Inspect</i> . Is the oil pump damaged or are the bolts loose?	—	Go to Step 10	Go to Step 11
10	Repair as required. Is the tapping noise gone?	—	System OK	Go to Step 11
11	Remove and inspect the valve lifters, the valve rocker arms and the valve pushrods. Refer to <i>Valve Rocker Arm and Pushrods Clean and Inspect</i> and <i>Valve Lifters and Guides Clean and Inspect</i> . Are the components worn or damaged?	—	Go to Step 12	Go to Step 13
12	Replace the components as required. Is the tapping noise gone?	—	System OK	Go to Step 13
13	Perform an engine camshaft lobe lift test. Refer to <i>Camshaft and Bearings Clean and Inspect</i> . Is the engine camshaft lobes within specifications?	—	Go to Step 15	Go to Step 14
14	Replace the engine camshaft and valve lifters. Is the tapping noise gone?	—	System OK	Go to Step 15
15	Remove the engine front cover and inspect the camshaft timing chain and sprockets for excessive wear or damage. Refer to <i>Timing Chain and Sprockets Clean and Inspect</i> . Are the components worn or damaged?	—	Go to Step 17	Go to Step 16
16	Replace the components as required. Is the tapping noise gone?	—	System OK	Go to Step 17
17	Perform a complete disassembly of the engine and inspect all components. Are the components worn or damaged?	—	Go to Step 18	System OK
18	Replace the components as required. Did you complete the worn or damaged component replacement?	—	System OK	—

Oil Consumption Diagnosis

Excessive oil consumption (not due to leaks) is the use 1.9 liters (2 quarts) of engine oil within 3,200 kilometers (2,000 miles). However, during initial engine break-in periods 4,828-6,437 kilometers (3,000-4,000 miles) oil consumption may exceed 1.9 liters (2 quarts) or more. The causes of excessive oil consumption include the following conditions:

- External oil leaks. Tighten the bolts and/or replace gaskets and oil seals as necessary.
- Incorrect oil level or improper reading of oil level indicator. With the vehicle on a level surface, allow adequate drain down time and check for the correct oil level.
- Improper oil viscosity. Use a recommended SAE viscosity for the prevailing temperatures.
- Continuous high speed operation and/or severe usage.
- Crankcase ventilation system restrictions or malfunctioning components. Possible improper PCV valve.
- Valve guides and/or valve stem oil seals worn, damaged or the seal omitted. Ream the valve guides and install oversize service valves and/or new valve stem oil seals.
- Piston rings broken, improperly installed, worn or not seated properly. Allow adequate time for the piston rings to seat. Replace broken or worn piston rings as necessary.
- Piston improperly installed or mis-fitted.

Oil Pressure Diagnosis and Testing

1. With the vehicle on a level surface, allow adequate drain down time (2-3 minutes) and measure for a low engine oil level.
Add the recommended grade engine oil, and fill the crankcase until the oil level measures FULL on the oil level indicator.
2. Operate the engine and verify low or no oil pressure on the vehicle oil pressure gauge or the oil indicator light.
Listen for a noisy valve train or a knocking noise.
3. Inspect for the following:
 - Engine oil diluted by moisture or unburned fuel mixtures
 - Improper engine oil viscosity for the expected temperature
 - Incorrect or faulty oil pressure gauge sensor
 - Incorrect or faulty oil pressure gauge
 - Plugged oil filter
 - Malfunctioning oil filter bypass valve

4. Remove the oil pressure gauge sensor or another engine block oil gallery plug.
5. Install an oil pressure gauge.
6. Start the engine and then allow the engine to reach normal operation temperature.
7. Measure the engine oil pressure at the following RPM:

Specification

- 7.1. 42 kPa (6psig) (minimum) at 1,000 RPM
- 7.2. 125 kPa (18 psig) (minimum) at 2,000 RPM
- 7.3. 166 kPa (24 psig) (minimum) at 4,000 RPM
8. If the engine oil pressure is below minimum specifications, inspect the engine for one or more of the following:
 - Oil pump worn or dirty
 - Malfunctioning oil pump pressure relief valve
 - Oil pump screen loose, plugged or damaged
 - Excessive bearing clearance
 - Cracked, porous or restricted oil galleries
 - Engine block oil gallery plugs missing or incorrectly installed
 - Broken valve lifters

Oil Leak Diagnosis

Step	Action	Value(s)	Yes	No
<p>Important: You can repair most fluid leaks by first visually locating the leak, repairing or replacing the component, or by resealing the gasket surface. Once the leak is identified, determine the cause of the leak. Repair the cause of the leak as well as the leak itself.</p>				
1	<ol style="list-style-type: none"> Operate the vehicle until it reaches normal operating temperature. Park the vehicle on a level surface, over a large sheet of paper or other clean surface. Wait (15 minutes) Check for drippings. <p>Are drippings present?</p>	—	Go to Step 2	System OK
2	Can you identify the type of fluid and the approximate location of the leak?	—	Go to Step 10	Go to Step 3
3	<ol style="list-style-type: none"> Visually inspect the suspected area. Use a small mirror to assist in looking at hard to see areas. Check for leaks at the following locations: <ul style="list-style-type: none"> Sealing surfaces Fittings Cracked or damaged components <p>Can you identify the type of fluid and the approximate location of the leak?</p>	—	Go to Step 10	Go to Step 4
4	<ol style="list-style-type: none"> Completely clean the entire engine and surrounding components. Operate the vehicle for several kilometers (miles) at normal operating temperature and at varying speeds. Park the vehicle on a level surface, over a large sheet of paper or other clean surface. Wait (15 minutes). Identify the type of fluid and the approximate location of the leak. <p>Can you identify the type of fluid and the approximate location of the leak?</p>	—	Go to Step 10	Go to Step 5
5	<ol style="list-style-type: none"> Visually inspect the suspected area. Use a small mirror to assist in looking at hard to see areas. Check for leaks at the following locations: <ul style="list-style-type: none"> Sealing surfaces Fittings Cracked or damaged components <p>Can you identify the type of fluid and the approximate location of the leak?</p>	—	Go to Step 10	Go to Step 6
6	<ol style="list-style-type: none"> Completely clean the entire engine and surrounding components. Apply an aerosol-type powder (baby powder, foot powder, etc.) to the suspected area. 			

Oil Leak Diagnosis (cont'd)

Step	Action	Value(s)	Yes	No
6	<p>3. Operate the vehicle for several kilometers (miles) at normal operating temperature and at varying speeds.</p> <p>4. Identify the type of fluid and the approximate location of the leak, from the discolorations in the powder surface.</p> <p>Can you identify the type of fluid and the approximate location of the leak?</p>	—	Go to Step 10	Go to Step 7
7	<p>1. Visually inspect the suspected area. Use a small mirror to assist in looking at hard to see areas.</p> <p>2. Check for leaks at the following locations:</p> <ul style="list-style-type: none"> • Sealing surfaces • Fittings • Cracked or damaged components <p>Can you identify the type of fluid and the approximate location of the leak?</p>	—	Go to Step 10	Go to Step 8
8	<p>Use <i>J 28428-E</i>, Dye and Light Kit, in order to identify the type of fluid and the approximate location of the leak. Refer to manufacturer's instructions when using the tool.</p> <p>Can you identify the type of fluid and the approximate location of the leak?</p>	—	Go to Step 10	Go to Step 9
9	<p>1. Visually inspect the suspected area. Use a small mirror to assist in looking at hard to see areas.</p> <p>2. Check for leaks at the following locations:</p> <ul style="list-style-type: none"> • Sealing surfaces • Fittings • Cracked or damaged components <p>Can you identify the type of fluid and the approximate location of the leak?</p>	—	Go to Step 10	System OK
10	<p>1. Inspect the engine for mechanical damage. Special attention should be shown to the following areas:</p> <ul style="list-style-type: none"> • Higher than recommended fluid levels • Higher than recommended fluid pressures • Plugged or malfunctioning fluid filters or pressure bypass valves • Plugged or malfunctioning engine ventilation system • Improperly tightened or damaged fasteners • Cracked or porous components <p>Can you identify the type of fluid and the approximate location of the leak?</p>	—	Go to Step 10	Go to Step 7
7	<p>1. Visually inspect the suspected area. Use a small mirror to assist in looking at hard to see areas.</p> <p>2. Check for leaks at the following locations:</p> <ul style="list-style-type: none"> • Sealing surfaces • Fittings • Cracked or damaged components <p>Can you identify the type of fluid and the approximate location of the leak?</p>	—	Go to Step 10	Go to Step 8
	<p>Use <i>J 28428-E</i>, Dye and Light Kit, in order to identify the type of fluid and the approximate location of the leak.</p>			

Symptoms - Drive Belt

Important: Review the system operation in order to familiarize yourself with the system functions. Refer to *Drive Belt System Description*.

Visual/Physical Inspection

- Inspect for aftermarket devices which could affect the operation of the drive belts.
- Inspect the easily accessible or visible system components for obvious damage or conditions which could cause the symptom.
- Inspect the drive belt for excessive wear, shredding or missing sections.
- Inspect the drive belt for contamination of excessive dirt, oil, coolant or other substances that may affect the drive belt operation.

Intermittent

- Drive belt symptoms may be from intermittent

failure of an accessory drive component.

- Drive belt symptoms may occur from changes in load of the accessory drive components.
- Ambient temperatures, moisture or engine operating temperature can affect the drive belt operation.

Symptoms List

Refer to a symptom diagnostic procedure from the following list in order to diagnose the symptom:

- *Drive Belt Chirping Diagnosis*
- *Drive Belt Squeal Diagnosis*
- *Drive Belt Whine Diagnosis*
- *Drive Belt Rumbling Diagnosis*
- *Drive Belt Vibration Diagnosis*
- *Drive Belt Falls Off Diagnosis*
- *Drive Belt Excessive Wear Diagnosis*

Drive Belt Chirping Diagnosis

Diagnostic Aids

The symptom may be intermittent due to moisture on the drive belt(s) or the pulleys. It may be necessary to spray a small amount of water on the drive belt(s) in order to duplicate the customers concern. If spraying water on the drive belt(s) duplicates the symptom, cleaning the belt pulleys may be the probable solution.

A loose or improper installation of a body component, a suspension component or other items of the vehicle may cause the chirping noise.

Test Description

The number(s) below refer to the step number(s) on the diagnostic table.

2. The noise may not be engine related. This step is to verify that the engine is making the noise. If the engine is not making the noise, do not proceed further with this table.
3. The noise may be an internal engine noise. Removing the drive belt and operating the engine for a brief period will verify the noise is related to the drive belt. When removing the drive belt(s), the water pump may not be operating and the engine may overheat. Also DTCs may set when the engine is operating with the drive belt removed.
4. Inspect all drive belt pulleys for pilling. Pilling is the small balls or pills or it can be strings in the drive belt grooves from the accumulation of rubber dust.

6. Misalignment of the pulleys may be caused from improper mounting of the accessory drive component, incorrect installation of the accessory drive component pulley or the pulley bent inward or outward from a previous repair. Test for a misaligned pulley using a straight edge in the pulley grooves across two or three pulleys. If a misaligned pulley is found, refer to that accessory drive component for the proper installation procedure for that pulley.
10. Inspecting of the fasteners can eliminate the possibility that a wrong bolt, nut, spacer or washer was installed.
12. Inspecting the pulleys for being bent should include inspecting for a dent or other damage to the pulleys that would prevent the drive belt from not seating properly in all of the pulley grooves or on the smooth surface of a pulley when the back side of the belt is used to drive the pulley.
14. Replacing the drive belt when it is not damaged or there is not excessive pilling will only be a temporary repair.

Drive Belt Chirping Diagnosis

Step	Action	Value(s)	Yes	No
<p>Notice: Refer to <i>Belt Dressing Notice</i> in Cautions and Notices.</p> <p>DEFINITION: The following items are indications of chirping:</p> <ul style="list-style-type: none"> • A high pitched noise that is heard once per revolution of the drive belt or a pulley. • It usually occurs on cold damp mornings. 				
1	Did you review the Drive Belt Symptom operation and perform the necessary inspections?	—	Go to Step 2	Go to <i>Symptoms - Drive Belt</i>
2	Verify that there is a chirping noise. Does the engine make the chirping noise?	—	Go to Step 3	Go to Diagnostic Aids
3	1. Remove the drive belt. 2. Operate the engine for no longer than 30 to 40 seconds. Does the chirping noise still exist?	—	Go to <i>Engine Noise Diagnosis</i>	Go to Step 4
4	Inspect for severe pilling exceeding 1/3 of the belt groove depth. Does the belt grooves have pilling?	—	Go to Step 5	Go to Step 6
5	Clean the drive belt pulleys with a suitable wire brush. Did you complete the repair?	—	Go to Step 15	Go to Step 6
6	Inspect for misalignment of the pulleys. Are any of the pulleys misaligned?	—	Go to Step 7	Go to Step 8
7	Replace or repair any misaligned pulleys. Did you complete the repair?	—	Go to Step 15	Go to Step 8
8	Inspect for bent or cracked brackets. Did you find any bent or cracked brackets?	—	Go to Step 9	Go to Step 10
9	Replace any bent or cracked brackets. Did you complete the repair?	—	Go to Step 15	Go to Step 10
10	Inspect for improper, loose or missing fasteners Did you find the condition?	—	Go to Step 11	Go to Step 12
11	Tighten any loose fasteners. Replace any improper or missing fasteners. Refer to <i>Fastener Tightening Specifications</i> . Did you complete the repair?	—	Go to Step 15	Go to Step 12
12	Inspect for a bent pulley. Did you find the condition?	—	Go to Step 13	Go to Step 14
13	Replace the bent pulley. Did you complete the repair?	—	Go to Step 15	Go to Step 14
14	Replace the drive belt. Refer to <i>Drive Belt Replacement</i> . Did you complete the repair?	—	Go to Step 15	Go to Diagnostic Aids
15	Operate the system in order to verify the repair. Did you correct the condition?	—	System OK	Go to Step 3

Drive Belt Squeal Diagnosis

Diagnostic Aids

A loose or improper installation of a body component, a suspension component or other items of the vehicle may cause the chirping noise.

If the noise is intermittent, verify the accessory drive components by varying their loads making sure they are operated to their maximum capacity. An overcharged A/C system, power steering system with a pinched hose or wrong fluid or a generator failing are suggested items to inspect.

Test Description

The number(s) below refer to the step number(s) on the diagnostic table.

2. The noise may not be engine related. This step is to verify that the engine is making the noise. If the engine is not making the noise, do not proceed further with this table.
3. The noise may be an internal engine noise. Removing the drive belt and operating the engine for a brief period will verify the noise is related to the drive belt. When removing the drive belt(s), the water pump may not be operating and the engine may overheat. Also DTCs may set when the engine is operating with the drive belt removed.
4. This test is to verify that an accessory drive component does not have a seized bearing. With the belt removed, test the bearings in the

accessory drive components for turning smoothly. Also test the accessory drive components with the engine operating by varying the load on the components to verify that the components operate properly.

5. This test is to verify that the drive belt tensioner operates properly. If the drive belt tensioner is not operating properly, proper belt tension may not be achieved to keep the drive belt from slipping, which could cause a squeal noise.
6. This test is to verify that the drive belt(s) is not too long, which would prevent the drive belt tensioner from working properly. Also, if an incorrect length drive belt was installed, it may not be routed properly and may be turning an accessory drive component in the wrong direction.
7. Misalignment of the pulleys may be caused from improper mounting of the accessory drive component, incorrect installation of the accessory drive component pulley or the pulley bent inward or outward from a previous repair. Test for a misaligned pulley using a straight edge in the pulley grooves across two or three pulleys. If a misaligned pulley is found, refer to that accessory drive component for the proper installation procedure for that pulley.
8. This test is to verify that the pulleys are the correct diameter or width. Using a known good vehicle compare the pulley sizes.

Drive Belt Squeal Diagnosis

Step	Action	Value(s)	Yes	No
<p>Notice: Refer to <i>Belt Dressing Notice</i> in Cautions and Notices.</p> <p>DEFINITION: The following items are indications of drive belt squeal:</p> <ul style="list-style-type: none"> • A loud screeching noise that is caused by a slipping drive belt (this is unusual for a drive belt with multiple ribs) • The noise occurs when a heavy load is applied to the drive belt, such as an air conditioning compressor engagement, snapping the throttle or slipping on a seized pulley or a faulty accessory drive component. 				
1	Did you review the Drive Belt Symptom operation and perform the necessary inspections?	—	Go to Step 2	Go to <i>Symptoms - Drive Belt</i>
2	Verify that there is a squeal noise. Does the engine make the squeal noise?	—	Go to Step 3	Go to Diagnostic Aids
3	1. Remove the drive belt(s). 2. Operate the engine for no longer than 30 to 40 seconds. Does the chirping noise still exist?	—	Go to <i>Engine Noise Diagnosis</i>	Go to Step 4
4	Inspect for an accessory drive component seized bearing or faulty accessory drive component. Did you find and correct the condition?	—	Go to Step 9	Go to Step 5

Drive Belt Squeal Diagnosis (cont'd)

Step	Action	Value(s)	Yes	No
5	Test the drive belt tensioner for proper operation. Refer to <i>Drive Belt Tensioner Diagnosis</i> . Did you find and correct the condition?	—	Go to Step 9	Go to Step 6
6	Inspect for the correct drive belt length. Refer to <i>Drive Belt Replacement</i> . Did you find and correct the condition?	—	Go to Step 9	Go to Step 7
7	Inspect for a misalignment of a pulley. Did you find and correct the condition?	—	Go to Step 9	Go to Step 8
8	Inspect for the correct pulley size. Did you find and correct the condition?	—	Go to Step 9	Go to Diagnostic Aids
9	Operate the system in order to verify the repair. Did you correct the condition?	—	System OK	Go to Step 3

Drive Belt Whine Diagnosis

Diagnostic Aids

The drive belt(s) will not cause the whine noise.

If the whine noise is intermittent, verify the accessory drive components by varying their loads making sure they are operated to their maximum capacity. An overcharged A/C system, power steering system with a pinched hose or wrong fluid or a generator failing are suggested items to inspect.

Test Description

The number(s) below refer to the step number(s) on the diagnostic table.

- 3. This test is to verify that the noise is being

caused by the drive belt(s) or the accessory drive components. When removing the drive belt(s), the water pump may not be operating and the engine may overheat. Also DTCs may set when the engine is operating with the drive belt(s) removed.

- 4. The inspection should include checking the drive belt tensioner and the drive belt idler pulley bearings. The drive belt(s) may have to be installed and the accessory drive components operated separately by varying their loads. Refer to the suspected accessory drive component for the proper inspection and replacement procedure.

Drive Belt Whine Diagnosis

Step	Action	Value(s)	Yes	No
Notice: Refer to <i>Belt Dressing Notice</i> in Cautions and Notices.				
DEFINITION: A high pitched continuous noise that may be caused by an accessory drive component failed bearing.				
1	Did you review the Drive Belt Symptom operation and perform the necessary inspections?	—	Go to Step 2	Go to <i>Symptoms-Drive Belt</i>
2	Verify that there is a whine noise. Does the engine make the whine noise?	—	Go to Step 3	Go to Diagnostic Aids
3	1. Remove the drive belt(s). 2. Operate the engine for no longer than 30 to 40 seconds. Does the whine noise still exist?	—	Go to <i>Engine Noise Diagnosis</i>	Go to Step 4
4	Inspect for a failed accessory drive component bearing. Did you find and repair the condition?	—	Go to Step 5	Go to Diagnostic Aids
5	Operate the system in order to verify the repair. Did you correct the condition?	—	System OK	—

Drive Belt Rumbling Diagnosis

Diagnostic Aids

Vibration from the engine operating may cause a body component or another part of the vehicle to make rumbling noise.

The drive belt(s) may have a condition that can not be seen or felt. Sometimes replacing the drive belt may be the only repair for the symptom.

If replacing the drive belt(s), completing the diagnostic table, and the noise is only heard when the drive component with a failure. Varying the load on the different accessory drive components may aid in identifying which component is causing the rumbling noise.

Test Description

The number(s) below refer to the step number(s) on the diagnostic table.

- This test is to verify that the symptom is present during diagnosing. Other vehicle components may cause a similar symptom.
- This test is to verify that the drive belt(s) is causing the rumbling noise. Rumbling noise may be confused with an internal engine noise due to the similarity in the description. Remove only one drive belt at a time if the vehicle has multiple drive belts. When removing the drive belt the water pump may not be operating and the engine may overheat. Also, DTC's may set when the engine is operating with the drive belt removed.
- Inspecting the drive belt(s) is to ensure that it is not causing the noise. Small cracks across the ribs of the drive belt will not cause the noise. Belt separation is identified by the plies of the belt separating and may be seen at the edge of the belt, or felt as a lump in the belt.
- Small amounts of pilling is a normal condition and acceptable. When the pilling is severe, the drive belt does not have a smooth surface for proper operation.

Drive Belt Rumbling Diagnosis

Step	Action	Value(s)	Yes	No
<p>Notice: Refer to <i>Belt Dressing Notice</i> in Cautions and Notices.</p> <p>DEFINITION:</p> <ul style="list-style-type: none"> A low pitch tapping, knocking or thumping noise heard at or just above idle. Heard once per revolution of the drive belt or a pulley. Rumbling may be caused from: <ul style="list-style-type: none"> Pilling, the accumulation of rubber dust that forms small balls (pills) or strings in the drive belt pulley groove The separation of the drive belt A damaged drive belt 				
1	Did you review the Drive Belt Symptom operation and perform the necessary inspections?	—	Go to Step 2	Go to <i>Symptoms-Drive Belt</i>
2	Verify that there is a rumbling noise. Does the engine make the rumbling noise?	—	Go to Step 3	Go to Diagnostic Aids
3	1. Remove the drive belt(s). 2. Operate the engine for no longer than 30 to 40 seconds. Does the rumbling noise still exist?	—	Go to <i>Engine Noise Diagnosis</i>	Go to Step 4
4	Inspect the drive belt(s) for damage, separation or sections of missing ribs. Did you find and repair the condition?	—	Go to Step 7	Go to Step 5
5	Inspect for severe pilling of more than 1/3 of the drive belt pulley grooves. Did you find severe pilling?	—	Go to Step 6	Go to Step 7
6	1. Clean the drive belt pulleys using a suitable wire brush. 2. Reinstall the drive belt. Refer to <i>Drive Belt Replacement</i> . Did you complete the repair?	—	Go to Step 8	Go to Step 7

Drive Belt Rumbling Diagnosis (cont'd)

Step	Action	Value(s)	Yes	No
7	Install a new drive belt. Refer to <i>Drive Belt Replacement</i> . Did you complete the replacement?	—	Go to Step 8	—
8	Operate the system in order to verify the repair. Did you correct the condition?	—	System OK	Go to Diagnostic Aids

Drive Belt Vibration Diagnosis

Diagnostic Aids

The accessory drive components can have an affect on engine vibration. Such as, but not limited to the A/C system overcharged, the power steering system restricted or the incorrect fluid or an extra load on the generator. To help identify an intermittent or an improper condition, vary the loads on the accessory drive components.

Test Description

The number(s) below refer to the step number(s) on the diagnostic table.

2. This test is to verify that the symptom is present during diagnosing. Other vehicle components may cause a similar symptom such as the exhaust system or the drivetrain.
3. This test is to verify that the drive belt(s) or accessory drive components may be causing the vibration. When removing the drive belt the water pump may not be operating and the engine may overheat. Also, DTC's may set when the engine is operating with the drive belt removed.

4. The drive belt(s) may cause a vibration. While the drive belt(s) is removed, inspect the condition of the belt.
6. Inspecting of the fasteners can eliminate the possibility that a wrong bolt, nut, spacer or washer was installed.
8. This step should only be performed if the fan is driven by the drive belt. Inspect the engine cooling fan for bent, twisted, loose or cracked blades. Inspect the fan clutch for smoothness, ease of turning. Inspect for a bent fan shaft or bent mounting flange.
9. This step should only be performed if the water pump is driven by the drive belt. Inspect the water pump shaft for being bent. Also inspect the water pump bearings for smoothness and excessive play. Compare the water pump with a known good water pump.
10. Accessory drive component brackets that are bent, cracked or loose may put extra strain on that accessory component causing it to vibrate.

Drive Belt Vibration Diagnosis

Step	Action	Value(s)	Yes	No
Notice: Refer to <i>Belt Dressing Notice</i> in Cautions and Notices.				
DEFINITION:				
<ul style="list-style-type: none"> • The vibration is engine-speed related. • The vibration may be sensitive to accessory load. 				
1	Did you review the Drive Belt Symptom operation and perform the necessary inspections?	—	Go to Step 2	Go to <i>Symptoms-Drive Belt</i>
2	Verify that the vibration is engine related. Does the engine make the vibration?	—	Go to Step 3	Go to Diagnostic Aids
3	1. Remove the drive belt(s). 2. Operate the engine for no longer than 30 to 40 seconds. Does the rumbling noise still exist?	—	Go to <i>Engine Related Vibration</i>	Go to Step 4
4	Inspect the drive belt(s) for wear, damage, debris build-up and missing drive belt ribs. Did you find any of these conditions?	—	Go to Step 5	Go to Step 6

Drive Belt Vibration Diagnosis (cont'd)

Step	Action	Value(s)	Yes	No
5	Install a new drive belt. Refer to <i>Drive Belt Replacement</i> . Did you complete the replacement?	—	Go to Step 11	—
6	Inspect for improper, loose or missing fasteners. Did you find any of these conditions?	—	Go to Step 7	Go to Step 8
7	Tighten any loose fasteners. Replace improper or missing fasteners. Refer to <i>Fastener Tightening Specifications</i> . Did you complete the repair?	—	Go to Step 11	—
8	Inspect for damaged fan blades or bent fan clutch shaft, if the fan is belt driven. Refer to <i>Fan Clutch Replacement</i> in Engine Cooling. Did you find and correct the condition?	—	Go to Step 11	Go to Step 9
9	Inspect for bent water pump shaft, if the water pump is belt driven. Refer to <i>Water Pump Replacement (4.3L Engine)</i> in Engine Cooling. Did you find and correct the condition?	—	Go to Step 11	Go to Step 10
10	Inspect for bent or cracked brackets. Did you find and correct the condition?	—	Go to Step 11	Go to Diagnostic Aids
11	Operate the system in order to verify the repair. Did you correct the condition?	—	System OK	Go to Step 3

Drive Belt Falls Off Diagnosis

Diagnostic Aids

If the drive belt(s) repeatedly falls off the drive belt pulleys, this is because of pulley misalignment.

An extra load that is quickly applied and released by an accessory drive component may cause the drive belt to fall off the pulleys. Verify the accessory drive components operate properly.

If the drive belt(s) is the incorrect length, the drive belt tensioner may not keep the proper tension on the drive belt.

Test Description

The number(s) below refer to the step number(s) on the diagnostic table.

- This inspection is to verify the condition of the drive belt. Damage may have occurred to the drive belt when the drive belt fell off. The drive belt may have been damaged, which caused the drive belt to fall off. Inspect the belt for cuts, tears, sections of ribs missing or damaged belt plies.
- Misalignment of the pulleys may be caused from improper mounting of the accessory drive

component, incorrect installation of the accessory drive component pulley or the pulley bent inward or outward from a previous repair. Test for a misaligned pulley using a straight edge in the pulley grooves across two or three pulleys. If a misaligned pulley is found, refer to that accessory drive component for the proper installation procedure of that pulley.

- Inspecting the pulleys for being bent should include inspecting for a dent or other damage to the pulleys that would prevent the drive belt from not seating properly in all of the pulley grooves or on the smooth surface of a pulley when the back side of the belt is used to drive the pulley.
- Accessory drive component brackets that are bent or cracked will let the drive belt fall off.
- Inspecting of the fasteners can eliminate the possibility that a wrong bolt, nut, spacer or washer was installed. Missing, loose or the wrong fasteners may cause pulley misalignment from the bracket moving under load. Over tightening of the fasteners may cause misalignment of the accessory component bracket.

Drive Belt Falls Off Diagnosis

Step	Action	Value(s)	Yes	No
Notice: Refer to <i>Belt Dressing Notice</i> in Cautions and Notices.				
DEFINITION: The drive belt falls off the pulleys or may not ride correctly on the pulleys.				
1	Did you review the Drive Belt Symptom operation and perform the necessary inspections?	—	Go to Step 2	Go to <i>Symptoms-Drive Belt</i>
2	Inspect for a damaged drive belt. Did you find the condition?	—	Go to Step 3	Go to Step 4
3	Install a new drive belt. Refer to <i>Drive Belt Replacement</i> . Does the drive belt continue to fall off?	—	Go to Step 4	System OK
4	Inspect for misalignment of the pulleys. Did you find and repair the condition?	—	Go to Step 12	Go to Step 5
5	Inspect for a bent or dented pulley. Did you find and repair the condition?	—	Go to Step 12	Go to Step 6
6	Inspect for a bent or cracked bracket. Did you find and repair the condition?	—	Go to Step 12	Go to Step 7
7	Inspect for improper, loose or missing fasteners. Did you find loose or missing fasteners?	—	Go to Step 8	Go to Step 9
8	Tighten any loose fasteners. Replace improper or missing fasteners. Refer to <i>Fastener Tightening Specifications</i> . Does the drive belt continue to fall off?	—	Go to Step 9	System OK
9	Test the drive belt tensioner for operating correctly. Refer to <i>Drive Belt Tensioner Diagnosis</i> . Does the drive belt tensioner operate correctly?	—	Go to Step 11	Go to Step 10
10	Replace the drive belt tensioner. Refer to <i>Drive Belt Tensioner Replacement</i> . Does the drive belt continue to fall off?	—	Go to Step 11	System OK
11	Inspect for failed drive belt idler and drive belt tensioner pulley bearings. Did you find and repair the condition?	—	Go to Step 12	Go to Diagnostic Aids
12	Operate the system in order to verify the repair. Did you correct the condition?	—	System OK	Go to Step 2

Drive Belt Excessive Wear Diagnosis

Diagnostic Aids

Excessive wear on a drive belt(s) is usually caused by an incorrect installation or the wrong drive belt for the application.

Minor misalignment of the drive belt pulleys will not cause excessive wear, but will probably cause the drive belt(s) to make a noise or to fall off.

Excessive misalignment of the drive belt pulleys will cause excessive wear but may also make the drive belt(s) fall off.

Test Description

The number(s) below refer to the step number(s) on the diagnostic table.

- This inspection is to verify the drive belt(s) is correctly installed on all of the drive belt pulleys. Wear on the drive belt(s) may be caused by mis-positioning the drive belt(s) by one groove on a pulley.
- The installation of a drive belt that is too wide or too narrow will cause wear on the drive belt. The drive belt ribs should match all of the grooves on all of the pulleys.
- This inspection is to verify the drive belt(s) is not contacting any parts of the engine or body while the engine is operating. There should be sufficient clearance when the drive belt accessory drive components load varies. The drive belt(s) should not come in contact with an engine or a body component when snapping the throttle.

Drive Belt Excessive Wear Diagnosis

Step	Action	Value(s)	Yes	No
Notice: Refer to <i>Belt Dressing Notice</i> in Cautions and Notices.				
DEFINITION: Wear at the outside ribs of the drive belt due to an incorrectly installed drive belt.				
1	Did you review the Drive Belt Symptom operation and perform the necessary inspections?	—	Go to Step 2	Go to <i>Symptoms-Drive Belt</i>
2	Inspect the drive belt(s) for the proper installation. Refer to <i>Drive Belt Replacement</i> . Did you find the condition?	—	Go to Step 5	Go to Step 3
3	Inspect for the proper drive belt. Did you find this condition?	—	Go to Step 5	Go to Step 4
4	Inspect for the drive belt rubbing against a bracket, hose or wiring harness. Did you find and repair the condition?	—	Go to Step 6	Go to Diagnostic Aids
5	Replace the drive belt. Refer to <i>Drive Belt Replacement</i> . Did you complete the replacement?	—	Go to Step 6	—
6	Operate the system in order to verify the repair. Does the drive belt continue to fall off?	—	System OK	—

Drive Belt Tensioner Diagnosis

Inspection Procedure

Notice: Allowing the drive belt tensioner to snap into the free position may result in damage to the tensioner.

1. Remove the drive belt. Refer to *Drive Belt Replacement*.
2. Position a hex-head socket on the drive belt tensioner pulley bolt head.
3. Move the drive belt tensioner through its full travel.
 - The movement should feel smooth
 - There should be no binding
 - The tensioner should return freely
4. If any binding is observed, replace the drive belt tensioner. Refer to *Drive Belt Tensioner Replacement*.
5. Install the drive belt. Refer to *Drive Belt Replacement*.

Important: Movement of the drive belt tensioner while the engine is operating is a normal operating condition. Do not replace the drive belt tensioner for this normal condition.